

Milling spindle ES 325 HSK 25



Milling spindle ES 325 HSK 25 with pneumatic tool charger

- Automatic tool locking with pneumatic piston
- Front ceramic bearing
- Rear ceramic bearing
- Lifetime lubrication
- air or water cooled max. speed: 40.000 rpm
- Spindle housing aluminium alloyed

Optional

- Linear tool changer HSK 25
- Clamp for HSK 25 and HSK 32
- Tool holders
- CoolMin extern
- Frequency converter SKC 4000
- Mounting plates
- different lengths of connecting cable

Technical specification

Rated speed [min ⁻¹]	40,000
Rated voltage [V]	380
Rated current [A]	4.0
max. rated output [kW]	2.0
Weight [kg]	7.0

Torque curves

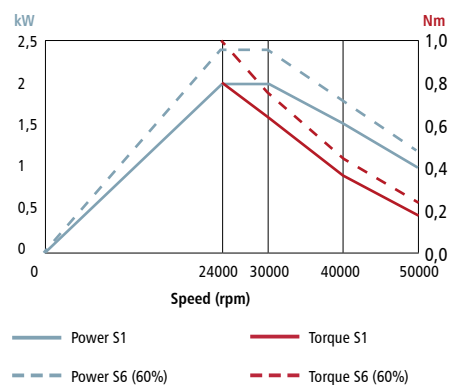

Dimensioned drawings

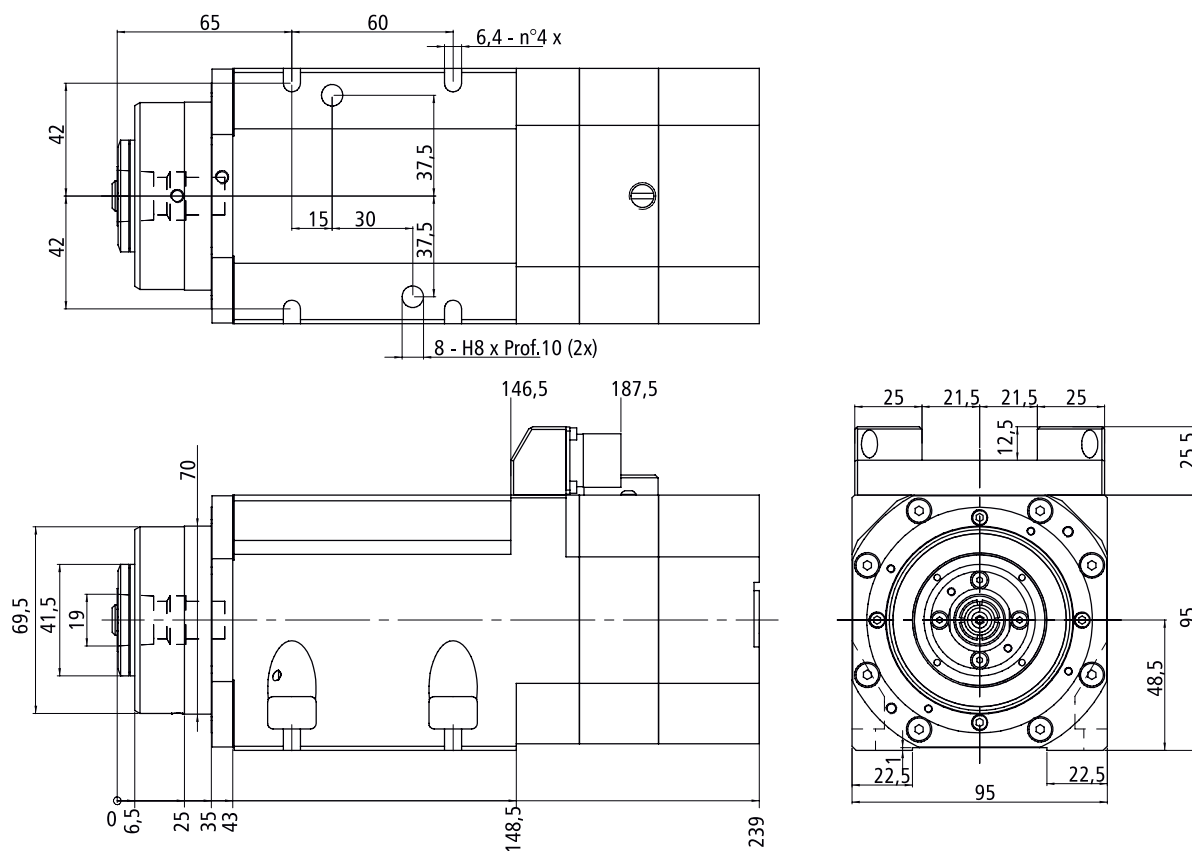

Ordering information

Part no.

Milling spindle ES 325 HSK 25	basic	478015 1340
	with converter**, maintenance unit and connection line 8 m, Collet EX 16, 6 mm, air or water cooled	310815 3511
Frequency converter	SKC 4000	311740 6500
CoolMin®	extern	239011 0119
Tool holder	HSK 25	477125
Collets	in Ø 1,0 / 1,5 / 2,0 / 2,5 / 3,0 / 4,0 / 5,0 / 6,0 / 7,0 / 8,0 / 9,0 / 10,0 (see catalogue pageSeite 9292)	477125 80XX
Clamps	for holding HSK 25	639100 0043
	for holding HSK 32	639100 0044
Tool change station***	linear changer HSK 25, 5-fold	239011 0051
	linear changer HSK 25, 10-fold	239011 0101
Mounting plate	at linear unit LES 5 and LES 21	277028 0001
Cooling unit 16 S	for milling spindle ES 325	492015 2001
Storage rack	for cooling unit 16 s	274507 6300

**converter pre-set for spindle

***Special change stations on request