

domiLINE 50

domiLINE 50 Schlitteneinheit
domiLINE 50 slide unit

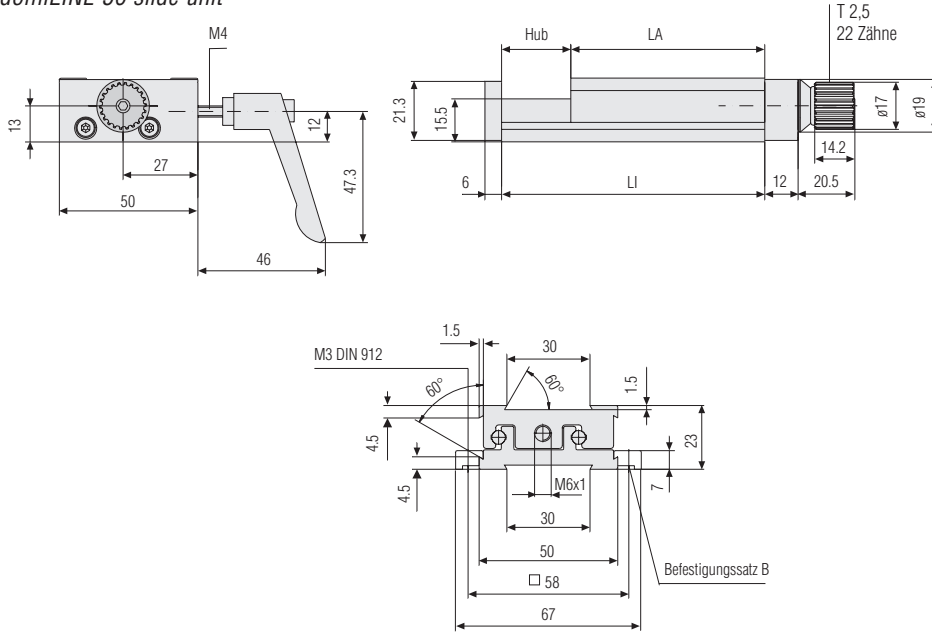

Befestigungssatz B
Fastening set B

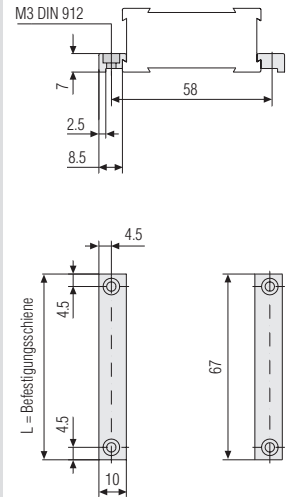

X-Y Verbindungssatz
X-Y connecting set

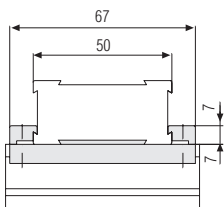

X-Z Verbindungssatz
X-Z connecting set

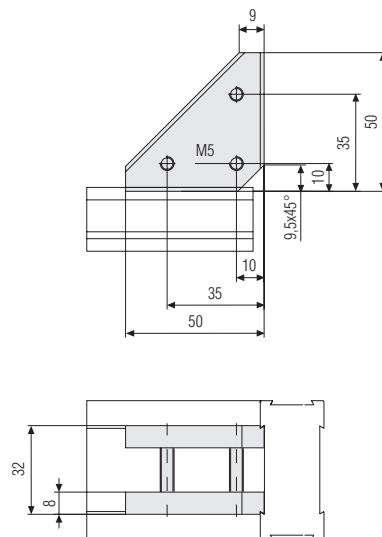

Dreheinheit
Rotational unit

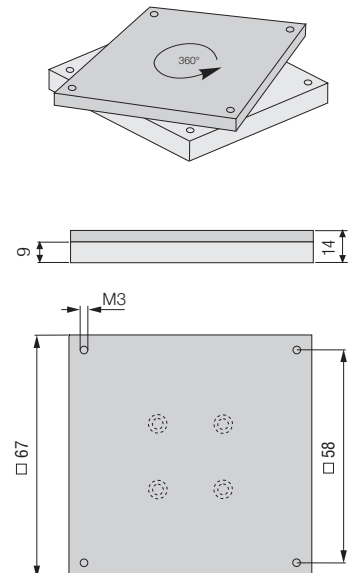

Standardeinheiten domiLINE 50 - Lagerware / Standard units domiLINE 50 - stock goods

B	LA	LI	Hub/Stroke	G	P	K	E	Gewicht/Weight	Art.-Nr./Art no.
50	70	95	25	G	1	-	E	270 g	1007779
50	70	120	50	G	1	-	E	310 g	1003455
50	70	145	75	G	1	-	E	350 g	1007782
50	70	170	100	G	1	-	E	390 g	1007783

Zubehör / Accessories

Bezeichnung / Designation	Art.-Nr./Art no.
Klemmhebel / Clamping lever	319214
Befestigungssatz, Standardlänge 67 mm / Fastening set, standard length 67 mm	319210
Montageplatte komplett, Länge 67 mm / Mounting plate complete, length 67 mm	319211
X-Y Verbindungssatz / X-Y connecting set	319212
X-Z Verbindungssatz / X-Z connecting set	319213
Zusatzplatte / Additional plate	319215
T-Nutenplatte / T-groove plate	319216
Befestigungssatz, Sonderlänge in mm / Fastening set, special length in mm	319217
Montageplatte, Sonderlänge in mm / Mounting plate, special length in mm	319218
Befestigungssatz mit Gewinde L = 67 mm / Fastening set, with thread L = 67 mm	319208
Befestigungssatz mit Gewinde Sonderlänge / Fastening set with thread special length	1014563
Befestigungsbohrung / Fastening hole	319201
Dreheinheit 50 kompl. mit Befestigungssatz / Rotary unit 50, complete	319231
Digital-Anzeige / Digital display	-
Handrad / Hand wheel	-

Montageplatte **M**
Mounting plate **M**

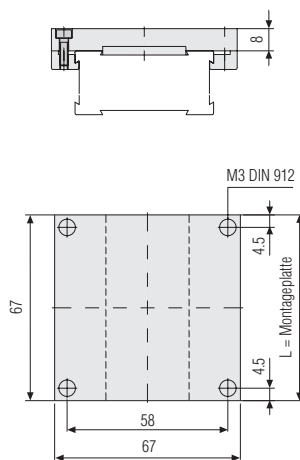

B = Breite mm
LA = Länge Außenschlitten
LI = Länge Innenschlitten
Hub = in mm
G = Gleitführung
P = Spindelsteigung
E = Endplatte

B = width mm
LA = length, outer slide
LI = length, inner slide
Stroke = in mm
G = slideway
P = spindle pitch
E = end plate

Zulässige Belastungen domiLINE 50
Maximum loads domiLINE 50

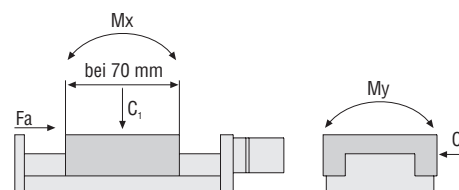

Fa = 120 N C₂ = 215 N
C₁ = 300 N Mx = 4 Nm
My = 5 Nm Mz = 3 Nm