

# Technical Documentation for Extraction and Filter Units **LAS Jumbo**

---



## Extraction and Filter Systems for Laser Smoke

Hazardous materials in the form of dust, floating particles, gases and fumes can often not be avoided in production processes. According to national regulations of air purification at the workplace they have to be removed from the air. Extraction units of the LAS series are especially designed for these tasks. Thus, hazardous effects on employees, products and machines are safely prevented. The optional recirculation ventilation helps to reduce energy costs. The simple and application-oriented, partially even individual, solutions result from longtime experience in theory and practice and a multitude of different application cases.

### Advantages of the LAS Series

- low noise level
- compact design
- high performance fans with low energy consumption
- recyclable filters with high capacity
- easy operation, maintenance and filter replacement

### Fields of Application

Extraction and filter units of the LAS series are especially designed for the work with laser systems. In almost every branch of industry dusts, floating particles, gases and fumes can be filtered from the air.

### Possible Connections

cutting and welding facilities, manufacturing cells, extraction arms, extraction cabinets, extraction hoods

### Filter Technology

application-oriented equipment including

- sublimation filter
- preliminary filter for coarse dust,
- floating particle filter H13
- adsorption filter

# Technical Documentation for Extraction and Filter Units **LAS Jumbo**



1. inlet stub
2. filter cartridge
3. air outlet
4. motor / fan
5. flow rate controller
6. power switch
7. loaded filter indicator

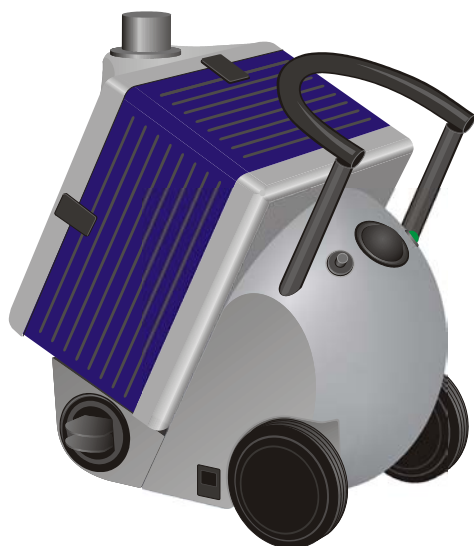
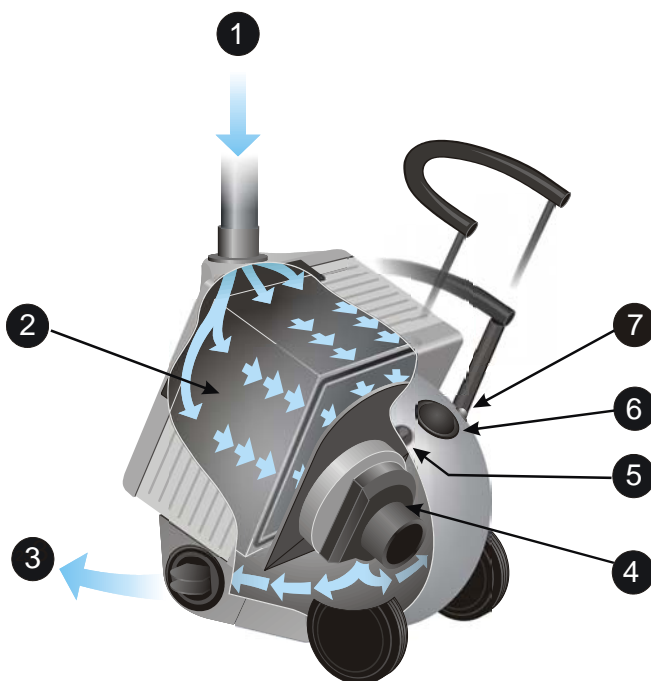

## Functional principle:

A special fan (4) with a large capacity of spare pressure creates an air flow adapted to the respective application at the clean air section of the filter cartridge (2). An optional flow rate controller is available. The hazardous air is reliably extracted (1) and cleaned. Because of the high purity of the filtered air it can be supplied back to the working area (3), thus, reducing energy costs. The different filters are combined in one filter cartridge and can be replaced singularly. The filter is recyclable.

# Technical Documentation for Extraction and Filter Units LAS Jumbo



## Specification / Fan Graph

Type Series		Jumbo
Parameters	Unit	
max. flow rate	M <sup>3</sup> /h	170
max. vacuum	Pa	2.800
nominal capacity	m <sup>3</sup> /h at Pa	80 / 1.400
nominal motor power	kW	0,15
nominal voltage	V	230
nominal current	A	0,95
frequency	Hz	50
type of protection	IP	54
noise level at 50%	dB(A)	45
noise level at 100%	dB(A)	49
weight	kg	18
flow rate controller		optional
loaded filter indicator		optional
inlet stub	mm	1 x Ø50 or 1 x Ø75 or 2 x Ø50
air outlet		2 x adjustable nozzles

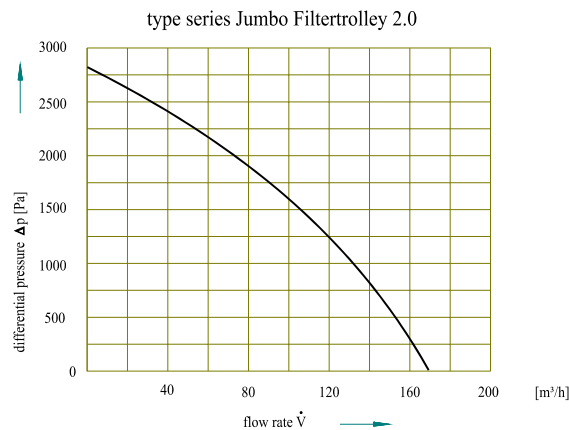

Technical Documentation for  
Extraction and Filter Units  
**LAS Jumbo**



**Dimensions Filterrolley 2.0 LAS**

alternatively: 1 x Ø 50mm  
1 x Ø 75mm  
2 x Ø 50mm

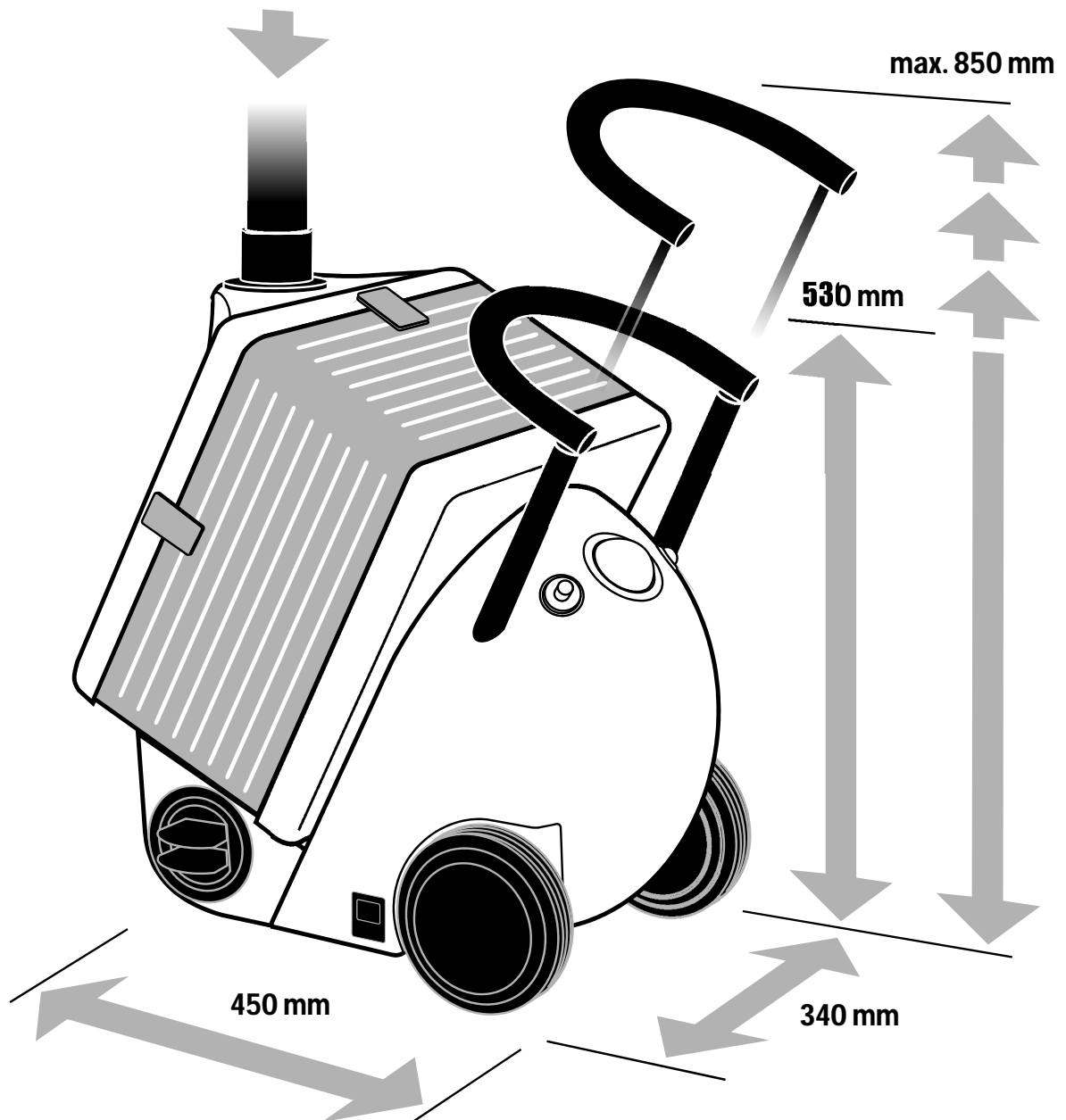

# Technical Documentation for Extraction and Filter Units **LAS Jumbo**



## Spare parts Filterrolley 2.0 LAS

