

DATRON Dental End Mills and Accessories

Solid carbide end mills for all
dental CNC milling machines
and materials



A Strong Team – For Your Individuality

The Basis for Your Success: Our Staff

With more than 190 dedicated and motivated employees, we count over 10,000 worldwide tool customers. As one of the largest suppliers of tool technologies in many different areas, we are able to offer -in addition to our extensive standard product range- customer-specific special solutions. DATRON is your faithful companion throughout the whole process, starting with the initial consultation, going through the design stage and ending with the realization.

Our Success is Based on Solid Experience

DATRON has developed and supplied carbide tools of the highest quality level for 20 years. As manufacturers of high-quality CNC milling and engraving systems, we have always placed special emphasis in cutting technology. The technological design and quality of CNC tools determine to a large extent the efficiency and quality of CNC machining. We can offer you CNC tools especially optimised for high speed machining resulting from our own development and tests, as well.

Quality at the Highest Level: The Key to Your Success



Our Experience and Expertise – Your Advantage and Gain

Due to the use of premium, ultra-fine grain carbides, you get particularly long durability by using DATRON tools. Further performance increase of the tools is achieved through the use of innovative coatings. Production of our tools on the most modern fully automatic grinding machines leads to consistent

high quality and very good price/performance ratio. Continuous quality checks and tests on our in-house milling machines -also under extreme conditions- guarantee the exceptional quality and performance of DATRON tools.

DATRON Dental End Mills

- For all common dental milling machines and materials
- Highest durability and quality with good price/performance ratio
- Extensive range and 100% availability
- Special end mills and customised end mills starting with lot size “1”
- All end mills are available separately
- Replacements or returns within 6 months
Replacements or returns only for unused tools in their original packaging.
We only charge a restocking fee of 8% of the net value of the goods.
Special and customised tools are excluded.
- Represented worldwide

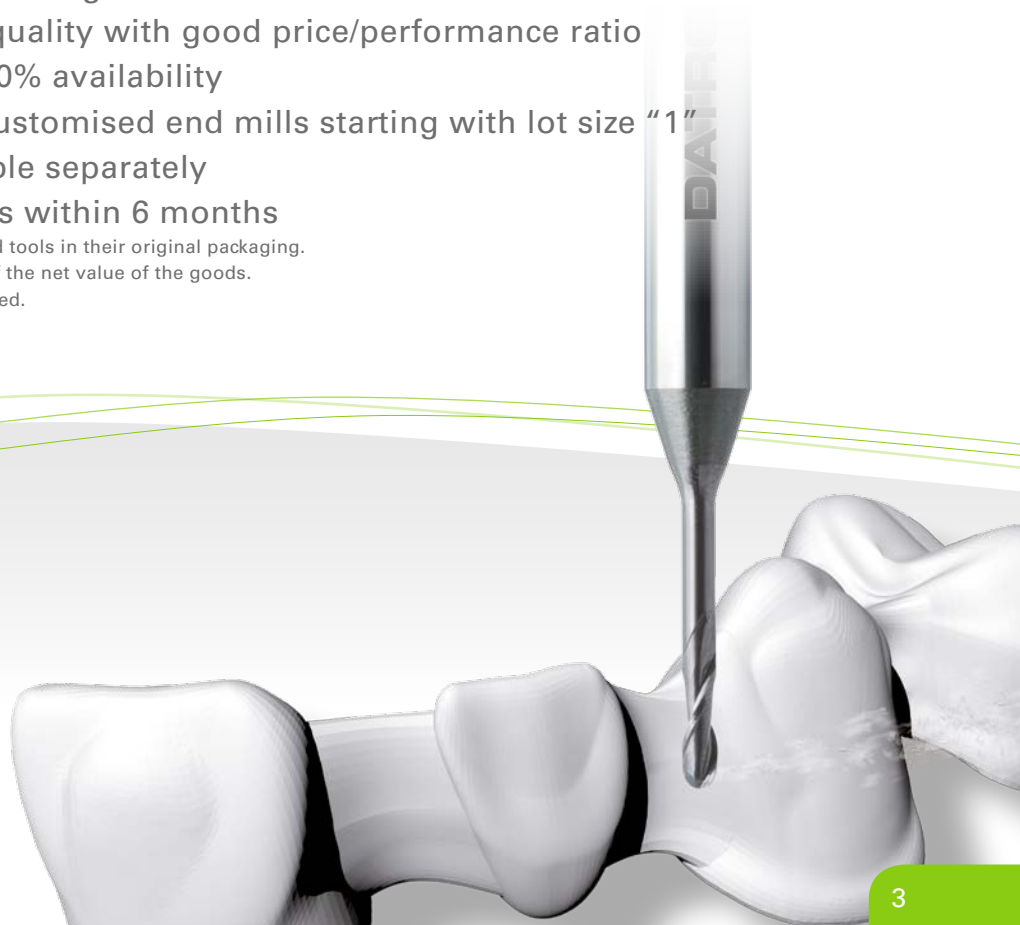

Represented Worldwide – Extreme Fast Delivery

DATRON is represented worldwide!

DATRON sells CNC milling tools over 6 national and 20 international representatives worldwide. This allows DATRON to ensure fast delivery to our customers, frequently within just 24 hours.*



* Only for selected standard tools

Table of Contents









DATRON	2-4
DATRON table of contents	5-9
DATRON dental milling tools for -almost- all milling systems	10
DATRON tool technology	11
DATRON coatings	12-13
DATRON list of abbreviations/symbol	14
DATRON customised tools	15
Your specifications	16
DATRON milling tools for zirconium oxide	17-23
 Ball nose end mills, double flute, uncoated	17-19
 Ball nose end mills, double flute, diamond coated	19-21
 Spherical end mills (Lollipop), double flute, diamond coated	22
 End mills, double flute with sharp edge, uncoated	23

Table of Contents

DATRON Milling Tools for Cobalt-chrome/Titanium (Hard Milling)		24-36
	Ball nose end mills, double flute, coated	24-25
	Conical pointed ball nose end mills, double flute, coated	26
	Spherical end mills (Lollipop), double flute, coated	27
	End mills, double flute, sharp edges, coated	28-29
	End mills, four flute with sharp edges, coated	30
	End mills with tip radius, double flute, coated	31
	End mills with tip radius, four flutes, coated	32
	End mills with double tip radius, four flutes, coated	33
	Centre drills, uncoated	34
	Drills, coated	35
	CVD end mills, single flute, diamond	36
DATRON Milling Tools for Soft Materials (PMMA/Wax)		37-39
	Micro ball nose end mills, double flute, uncoated	37
	Ball nose end mills, double flute, uncoated	38-39
DATRON Milling Tools for Composites (High-Class/Strongly Abrasive)		40-43
	Micro ball nose end mills, double flute, coated	40
	Ball nose end mills, double flute, coated	41
	Ball nose end mills, four flutes, coated, with Weldon clamping surface	42
	Ball nose end mills, double flute, coated, with Weldon clamping surface	43

DATRON Diamond Grinders for Disilicates (glass ceramics)		44-45
	Diamond grinders	44
	Diamond grinders	45
DATRON Milling Tools for LAVA Milling Machines, Types 240, 400, 500		46
	Available types: 1, 2, 3, 4, 5, 6 & 7	46
DATRON Milling Tools for Charly Robot Milling Machines (2U, 4U, Charly Dental)		47
	Entire spectrum available, diamond-coated	47
DATRON Milling Tools for Cercon Brain Expert (Zirconium)		48
	3, 2, 1 mm strategy, uncoated	48
DATRON Milling Tools for Cercon Brain Expert (PMMA/Wax)		49
	3, 2, 1 mm strategy, uncoated	49
DATRON Milling Tools for Open KAVO Everest Milling Systems		50
	Ball nose end mills for ZrO ₂ , PMMA/Wax and High-Class	50

DATRON Accessories and Consumables

51-64

	Limit stop rings for systems with direct shank clamping	51
	Insertion tools for limit stop rings	52
	Adapter collets	53
	HSK-E 25 collets	54
	Lubricants and additives	55
	Milling materials/Cobalt chromium blanks by Eisenbacher	56
	Milling materials/Keralloy blanks by SILADENT	57
	Milling materials/Titanium grade 2/4 blanks by SILADENT	58
	Milling materials/Titanium grade 5 ZENOTEC Ti blanks by Wieland	59
	Accessories for DATRON D5 milling/grinding machine	60-61
	Accessories for DATRON D5/Dental - Machine environment	62
	Accessories for DATRON D5 milling/grinding machine - Cleaning and Maintenance	63
	Accessories for DATRON dental milling machine	64

DATRON CAM-Software		65-66
	WorkNC (Sescoi)	65
	hyperDENT (Follow Me!)	66
DATRON Scanner		67-69
	Imetric	67
	3shape	68
	dental wings	69
DATRON Furnaces		70
	mihm-vogt	70
	DEKEMA	70
DATRON D5 Milling/Grinding Machine at a Glance		71
DATRON SERVICE D5 Milling/Grinding Machine (Machine Check-up/Maintenance)		72
DATRON Dental-C Milling Machine at a Glance		73
Your DATRON Dental Team – Who We Are!		74-75
Parameter Calculation/Guidelines		76
Fax Orders - Copy, Fill-in, Fax it!		77

DATRON Dental Milling Tools – for (almost) all Milling Systems

DATRON milling tools can be used -among other- with the following systems. Users with systems listed below are already profiting from DATRON milling tools. Our customers' feedback attests to their high quality, durability and good price/performance ratio.

3M Espe	LAVA CNC 240, 400, 500	46
BZT Dental	Microdental ECO and HSC	17-18/20-23/37-38/41/46
Charly Robot	2U, 4U, Charly Dental	47
DATRON AG	DATRON Dental, DATRON D5	17-47/50
Degu Dent	Cercon Brain Expert	48/49
DMG	U10, U20	17-47/50
GF Agie	Chamille Mikron HSM 400U	17-47/50
H-E-I-Z	Denta Cut 300	17-18/20-23/37-38/41/46
imes-icore	Coritec 340i, 440i, 450i, 540i, 550i, 750i	17-47/50*
KAVO	Everest (open variant)	49
Laserdenta	Openmill 400, Openmill 500	17-18/20-23/37-38/41/46
MB	Cobra Mill	17-47/50*
Pou Chen Group	TDS (Turbo Dent System)	21/25/39
Rübeling + Klar	Organical, Multi	17-47/50*
Renishaw	Incise	18/20
RoboCAM	RoboMill 4, RoboMill 5	17-18/20-23/37-38/41/46
Roland	MDX-40A, DWX-30, DWX-50	17-18/20-23/37/38/41/46
Röders	RX-D4, RX-D5	17-47/50
Wieland	ZENOTEC 2100, 3020, 4030, 4820, 6200, 6400	17-47/50*
Wissner	Gamma 202	17-47/50
yenadent	D20, D30, D40, DC40	21/25/39

* Depending on the spindle version

Improve Quality and Reduce Costs – Tool Technology by DATRON



Quality and Precision “Made in Germany”

Twenty 20 years of experience in manufacturing milling tools on the most modern automatic grinding machines lead to the ever-constant precision and high quality of all DATRON milling tools. Only through permanent quality controls and tests can DATRON AG offer its steady competitive advantage.



Cost-effectiveness

Through the use of premium carbides in ultra-fine grain quality, tailored to the individual application fields, you achieve extra-high durability with DATRON milling tools while maintaining high quality standards.



DATRON Technology

The cutting geometry of each individual DATRON tool is the result of DATRON’s long-standing expertise in the field of Hsc-milling (high-speed cutting). Continuous development and optimisation are your guarantee for obtaining cutting-edge technology from us.

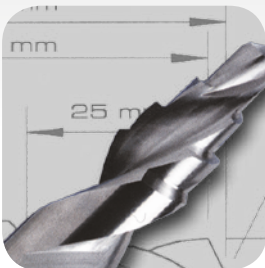

Custom Tools Service

DATRON custom tools solve your milling issues!
We manufacture custom carbide tools following your drawings or specifications according to the usual DATRON quality.

DATRON Coatings – Harder than Steel

Diamond Coating

Superior hardness and chemical resistance

The unique properties of multi-layer diamond-coatings offer significant performance potentials which are ideal for machining highly abrasive materials such as zirconium oxide. The combination of a hardness of over 10,000 HV and a coefficient of friction of 0.15 guarantees long durability.



Coating Properties

Material	Diamond
Micro hardness	10.000 HV
Coefficient of friction	0,15
Max. operating temperature	700° C
Colour	Dark grey

X.CEED Coating

Hardness and high adhesion

Hardness, oxidation resistance and thermal stability of X.CEED are optimised for use in carbide and high-speed machining, even with highly strong and difficult to machine materials such as CoCr and titanium.



Coating Properties

Material	AlTiN
Micro hardness	3300 HV
Coefficient of friction	0,40
Max. operating temperature	900° C
Colour	Blue-grey

XTS Coating

Low coefficient of friction and hot hardness

Technical high-tech plastics can be made of different ingredients. The proportion of glass partially increases demands on the tool. Due to its extremely high hot hardness (3,200 HV up to ,1100° C) and low coefficient of friction (0.35 dry), DATRON's XTS coating is an absolute must when working with composites.

Coating Properties

Material	AlCrN Variant
Micro hardness	3300 HV
Coefficient of friction	0,35 - 0,40
Max. operating temperature	>1100° C
Colour	Blue-grey



ALCRONA Coating

The all-rounder

Excellent wear resistance, thermal shock resistance and hot hardness: these are the these are the qualities that have been modified significantly in order to improve the proven ALCRONA coating still more. The performance profile of the new layer is increased significantly by optimising process parameters and modifying the layer structure. ALCRONA is the new all-rounder in machining.

Coating Properties

Material	AlCrN
Micro hardness	3200 HV
Coefficient of friction	0,35 (dry against steel)
Max. operating temperature	1100° C
Colour	Light grey



List of Symbols & Abbreviations



Machinable materials



Number of flutes



Solid carbide



Spiral angle



Machining direction



Shank shape



Ball nose



Sharp edge flute



Flute with edge radius



Diamond flute



Spherical end mill



Cooling



Point angle

D1	Flute diameter
D2	Shank diameter
D3	Toric cut diameter
L1	Total length
L2	Flute length
L3	Usable length
α	Angle
R	Radius
COAT	Coating

Your Custom End Mill – Copy, Enter Your Data, Send It!

**Do you need a special tool?
That's no problem at all at DATRON!**

We manufacture special and custom tools from batch size 1 in no time.

Just send us a drawing or enter the desired features into the table below and send it by fax or by e-mail to us. We will let you have a custom quote.

Of course you can also download the data sheet from www.individualfraeser.datron.de.

By fax: **+49 (0) 61 51 - 14 19 - 69**

By e-mail: **mini-tools@datron.de**



Notes:

Description	Your custom data
End mill similar to item	
D1 Flute diameter	
D2 Shank diameter	
D3 Toric cut diameter	
L1 Total length	
L2 Flute length	
L3 Usable length	
R Radius	
COAT Coating	

Your Specifications – For Your Special and Custom End Mills!

For those of your custom milling tools not included in the standard range. Here you can enter all technical data, including price, and the corresponding item number to have these data on hand next time you need them.

Item No.	D1 (mm)	D2 (mm)	D3 (mm)	L1 (mm)	L2 (mm)	L3 (mm)	R (mm)	COAT	€

Ball Nose End Mill for Zirconium Oxide – Uncoated



End mill type: Ball nose 180°

Number of flutes: Two

Versions: Short, long

Coating (CT): None

Features: Extremely sharp flutes, as not post-treated

Indications: Caps, crowns (anatomic, anatomically reduced), bridges, bars, individual abutments, screwed-retained applications, 3D free-form surfaces

For users of: BZT Dental, DATRON, DMG, Mikron, H-E-I-Z, imes-icore, Laserdenta, Cobra Mill, Organical, RoboCAM, Röders, Roland, Wieland, Wissner **and many other systems.**

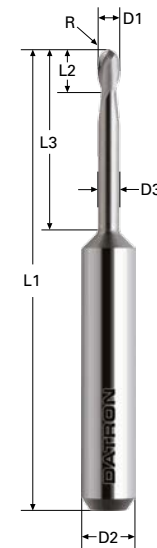

- ZrO₂
- 2 flutes
- Micro Grain
- 30°
- DIN 6535 Form HA
- Air cooling
- Dry machining

3 mm Shank, Short Neck

Item No.	D1 (mm)	D2 (mm)	L1 (mm)	L2 (mm)	R (mm)
00684003	0.30	3.00	40.00	0.50	0.15
00684005	0.50	3.00	40.00	0.80	0.25
00684007	0.70	3.00	40.00	2.10	0.35

3 mm Shank, Short Neck

Item No.	D1 (mm)	D2 (mm)	D3 (mm)	L1 (mm)	L2 (mm)	L3 (mm)	R (mm)
00782004	0.40	3.00	0.35	40.00	0.60	2.00	0.20
00782005	0.50	3.00	0.45	40.00	0.75	4.00	0.25
00782005L	0.50	3.00	0.45	40.00	0.75	10.00	0.25
00782006	0.60	3.00	0.55	40.00	0.90	4.00	0.30
00782008	0.80	3.00	0.75	40.00	1.20	6.00	0.40
00782010	1.00	3.00	0.95	40.00	1.50	6.00	0.50
00782011	1.00	3.00	0.95	40.00	1.50	9.00	0.50
00782012	1.20	3.00	1.15	40.00	1.80	9.00	0.60
00782015	1.50	3.00	1.45	40.00	2.20	9.00	0.75
00782020	2.00	3.00	1.95	40.00	3.00	12.00	1.00



Ball Nose End Mills for Zirconium Oxide – Uncoated

3 mm Shank, Long Neck

Item no.	D1 (mm)	D2 (mm)	D3 (mm)	L1 (mm)	L2 (mm)	L3 (mm)	R (mm)
00782106	0.60	3.00	0.55	48.00	2.50	10.00	0.30
00782108	0.80	3.00	0.75	48.00	3.00	12.00	0.40
0078211K	1.00	3.00	0.95	48.00	4.00	14.00	0.50
00782110	1.00	3.00	0.95	48.00	4.00	18.00	0.50
00782115	1.50	3.00	1.45	48.00	4.00	18.00	0.75
00782120	2.00	3.00	1.95	48.00	4.50	22.00	1.00
00782125	2.50	3.00	2.40	48.00	6.00	20.00	1.25
00782130	3.00	3.00	2.90	48.00	6.00	22.00	1.50

6 mm Shank, Long Neck

Item no.	D1 (mm)	D2 (mm)	D3 (mm)	L1 (mm)	L2 (mm)	L3 (mm)	R (mm)
00782706	0.60	6.00	0.55	50.00	2.50	10.00	0.30
00782708	0.80	6.00	0.75	50.00	3.00	12.00	0.40
00782710	1.00	6.00	0.95	50.00	4.00	18.00	0.50
00782715	1.50	6.00	1.45	50.00	4.00	18.00	0.75
00782720	2.00	6.00	1.95	50.00	4.50	22.00	1.00
00782725	2.50	6.00	2.40	50.00	6.00	25.00	1.25
00782730	3.00	6.00	2.80	50.00	6.00	25.00	1.50

Ball Nose End Mills for Zirconium Oxide – Uncoated & Coated with Clamping Surface (HB)



End mill type: Ball nose 180°

Number of flutes: Two

Versions: Short, long

Coating (CT): Without & Diamond

Features, uncoated: Extremely sharp flutes, as not post-treated

Features, coated: Extremely high durability due to its diamond coating

Indications: Caps, crowns (anatomic, anatomically reduced), bridges, bars, individual abutments, screwed-retained applications, 3D free-form surfaces

For users of: DATRON, DMG, KAVO, Mikron, imes-icore, Cobra Mill, Organical, Röders, Wieland, Wissner **and other systems.**



- ZrO₂
- 2 flutes
- Micro Grain
- 30°
- DIN 6535 Form HB
- Air cooling
- Dry machining

6 mm Shank, Long Neck

Item no.	D1 (mm)	D2 (mm)	D3 (mm)	L1 (mm)	L2 (mm)	L3 (mm)	R (mm)	CT
00782807A	0.70	6.00	0.60	54.00	2.00	10.00	0.35	x
00782810A	1.00	6.00	0.90	54.00	1.50	18.00	0.50	x
00782820A	2.00	6.00	1.90	54.00	3.00	20.00	1.00	x

6 mm Shank, Short & Long Neck

Item no.	D1 (mm)	D2 (mm)	D3 (mm)	L1 (mm)	L2 (mm)	L3 (mm)	R (mm)	CT
00782705A	0.50	6.00	0.40	48.00	1.00	2.50	0.25	
00782910A	1.00	6.00	0.90	54.00	1.50	16.00	0.50	
00782920A	2.00	6.00	1.90	54.00	3.00	20.00	1.00	

Ball Nose End Mills for Zirconium Oxide – Diamond Coated

End mill type:	Ball nose 180°
Number of flutes:	Two
Versions:	Long, xtra long
Coating (CT):	Diamond
Features:	Extremely high durability due to its diamond coating
Indications:	Caps, crowns (anatomic, anatomically reduced), bridges, bars, individual abutments, screwed-retained applications, 3D free-form surfaces

For users of: BZT Dental, DATRON, DMG, Mikron,
H-E-I-Z, imes-icore, Laserdenta, Cobra Mill, Organical, RoboCAM, Röders,
Roland, Wieland, Wissner, TDS, Yenadent **and other systems.**

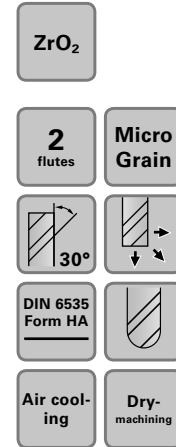
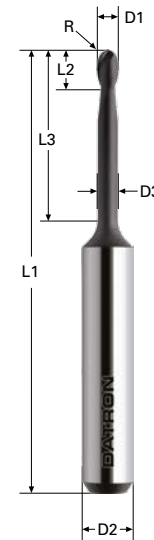

3 mm Shank, Long Neck

Item no.	D1 (mm)	D2 (mm)	D3 (mm)	L1 (mm)	L2 (mm)	L3 (mm)	R (mm)	CT
00782206	0.60	3.00	0.55	48.00	2.50	10.00	0.30	x
00782208	0.80	3.00	0.75	48.00	3.00	12.00	0.40	x
00782210	1.00	3.00	0.95	48.00	4.00	16.00	0.50	x
00782215	1.50	3.00	1.45	48.00	4.00	18.00	0.75	x
00782220	2.00	3.00	1.95	48.00	4.50	20.00	1.00	x
00782225	2.50	3.00	2.40	48.00	4.50	22.00	1.25	x
00782230	3.00	3.00	2.90	48.00	6.00	25.00	1.50	x

3 mm Shank, Long Neck, with Conical Outlet and Differentiated Spin

Item no.	D1 (mm)	D2 (mm)	D3 (mm)	L1 (mm)	L2 (mm)	L3 (mm)	R (mm)	CT
0073380F	0.50	3.00	0.45	48.00	2.50			
0073380G	1.00	3.00	0.95	50.00	1.00	12.00	0.50	x
0073380H	1.50	3.00	1.40	50.00	1.55	18.00	0.75	x
0073380I	3.00	3.00	2.85	50.00	6.65	17.00	1.50	x



3 mm Shank, Xtra Long Neck

Item no.	D1 (mm)	D2 (mm)	D3 (mm)	L1 (mm)	L2 (mm)	L3 (mm)	R (mm)	CT
0078221L	1.00	3.00	0.95	48.00	4.00	18.00	0.50	x
0078222L	2.00	3.00	1.95	48.00	4.50	25.00	1.00	x
0078225L	2.50	3.00	2.40	48.00	4.50	25.00	1.25	x

4 mm Shank, Long Neck

Item no.	D1 (mm)	D2 (mm)	D3 (mm)	L1 (mm)	L2 (mm)	L3 (mm)	R (mm)	CT
00783206	0.60	4.00	0.55	45.00	2.50	10.00	0.30	x
00783210	1.00	4.00	0.95	48.00	4.00	18.00	0.50	x
00783220	2.00	4.00	1.95	48.00	4.50	20.00	1.00	x
00783225	2.50	4.00	2.40	48.00	5.00	22.00	1.25	x

6 mm Shank, Long Neck

Item no.	D1 (mm)	D2 (mm)	D3 (mm)	L1 (mm)	L2 (mm)	L3 (mm)	R (mm)	CT
00782806	0.60	6.00	0.55	50.00	2.50	10.00	0.30	x
00782808	0.80	6.00	0.75	50.00	3.00	12.00	0.40	x
00782810	1.00	6.00	0.95	50.00	4.00	16.00	0.50	x
00782815	1.50	6.00	1.45	50.00	4.00	18.00	0.75	x
00782820	2.00	6.00	1.95	50.00	4.50	20.00	1.00	x
00782825	2.50	6.00	2.40	50.00	4.50	22.00	1.25	x
00782830	3.00	6.00	2.80	50.00	6.00	25.00	1.50	x

6 mm Shank, Xtra Long Neck

Item no.	D1 (mm)	D2 (mm)	D3 (mm)	L1 (mm)	L2 (mm)	L3 (mm)	R (mm)	CT
0078281L	1.00	6.00	0.95	50.00	4.00	18.00	0.50	x
0078282L	2.00	6.00	1.95	50.00	4.50	25.00	1.00	x
0078285L	2.50	6.00	2.40	50.00	4.50	25.00	1.25	x

Spherical End Mills (Lollipop) for Zirconium Oxide – diamond coated

End mill type: Spherical 270° (Lollipop)

Number of flutes: Two

Versions: Long

Coating (CT): Diamond

Features: High machining options for undercuts, without having to tilt the workpiece

Indications: Caps, crowns (anatomic, undercut machining, outer contours, inner contours)

For users of: BZT Dental, DATRON, DMG, Mikron, H-E-I-Z, imes-icore, Laserdenta, Cobra Mill, Organical, RoboCAM, Röders, Roland, Wieland, Wissner **and other systems.**

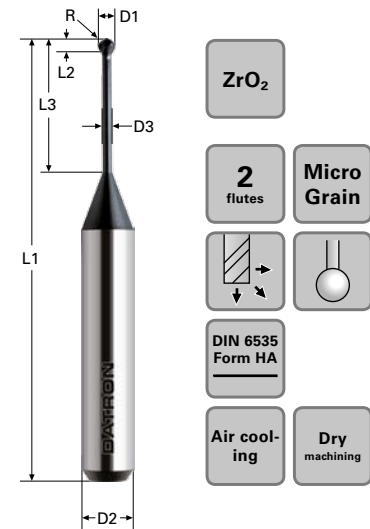

3 mm Shank, Long Neck

Item No.	D1 (mm)	D2 (mm)	D3 (mm)	L1 (mm)	L3 (mm)	R (mm)	Sphere (Degrees)	CT
00784310	2.00	3.00	1.10	40.00	14.00	1.00	270	x

6 mm Shank, Long Neck

Item No.	D1 (mm)	D2 (mm)	D3 (mm)	L1 (mm)	L3 (mm)	R (mm)	Sphere (Degrees)	CT
00784610	2.00	6.00	1.10	50.00	14.00	1.00	270	x

End Mills for Zirconium Oxide – uncoated



- End mill type:** End mill with sharp edge 90°
- Number of flutes:** Two
- Versions:** Short
- Coating (CT):** None
- Features:** Very sharp flutes, precise plane face machining, ideal for screw contact surfaces and/or contour machining
- Indications:** Bars, individual abutments, screwed-retained applications, interface connections (inside/outside), screw contact surfaces

For users of: BZT Dental, DATRON, DMG, Mikron, H-E-I-Z, imes-icore, Laserdenta, Cobra Mill, Organical, RoboCAM, Röders, Roland, Wieland, Wissner **and other systems.**

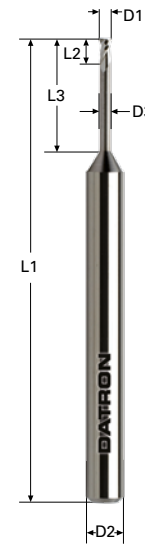

- ZrO₂
- 2 flutes
- Micro Grain
- 30°
- DIN 6535 Form HA
- Air cooling
- Dry machining

3 mm Shank, Short Neck

Item No.	D1 (mm)	D2 (mm)	D3 (mm)	L1 (mm)	L2 (mm)	L3 (mm)
00781005	0.50	3.00	0.45	40.00	0.75	4.00
00781006	0.60	3.00	0.55	40.00	0.90	4.00
00781007	0.70	3.00	0.65	40.00	1.05	4.00
00781008	0.80	3.00	0.75	40.00	1.20	6.00
00781009	0.90	3.00	0.85	40.00	1.30	6.00
00781010	1.00	3.00	0.95	40.00	1.50	6.00
00781011	1.00	3.00	0.95	40.00	1.50	9.00
00781012	1.20	3.00	1.15	40.00	1.80	9.00
00781015	1.50	3.00	1.45	40.00	2.20	9.00
00781020	2.00	3.00	1.95	40.00	3.00	12.00

Ball Nose End Mills for Cobalt-Chrome/Titanium – coated

- End mill type:** Ball nose 180°
- Number of flutes:** Two
- Versions:** Short, Long, Xtra Long
- Coating (CT):** X.CEED
- Features:** High coating hardness especially for hardened and difficult to machine materials
- Indications:** Caps, crowns (anatomic, anatomically reduced), bridges, bars, individual abutments, screwed-retained applications, 3D free-form surfaces

For users of: DATRON, DMG, Mikron, imes-icore, Cobra Mill, Organical, Röders, Wieland, Wissner, TDS, Yenadent **and many other systems.**

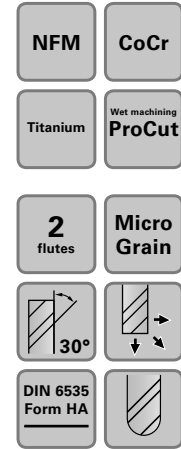
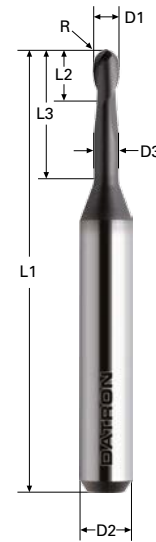

3 mm Shank, Short Neck

Item No.	D1 (mm)	D2 (mm)	L1 (mm)	L2 (mm)	R (mm)	CT
00684004	0.40	3.00	40.00	1.20	0.20	x
00684010	0.50	3.00	40.00	1.50	0.25	x
00684006	0.60	3.00	40.00	1.80	0.30	x

3 mm Shank, Long Neck

Item No.	D1 (mm)	D2 (mm)	D3 (mm)	L1 (mm)	L2 (mm)	L3 (mm)	R (mm)	CT
00782308	0.80	3.00	0.75	38.00	3.50	8.00	0.40	x
00782310	1.00	3.00	0.95	38.00	3.00	8.00	0.50	x
00782315	1.50	3.00	1.45	38.00	4.00	12.00	0.75	x
00782320	2.00	3.00	1.90	38.00	3.50	12.00	1.00	x
00782325	2.50	3.00	2.40	38.00	4.50	15.00	1.25	x
00782330	3.00	3.00	2.80	38.00	5.50	15.00	1.50	x



4 mm Shank, Long Neck

Item No.	D1 (mm)	D2 (mm)	D3 (mm)	L1 (mm)	L2 (mm)	L3 (mm)	R (mm)	CT
00784408	0.80	4.00	0.75	50.00	3.00	10.00	0.40	x
00784410	1.00	4.00	0.95	50.00	3.50	12.00	0.50	x
00784415	1.50	4.00	1.45	50.00	4.00	14.00	0.75	x
00784420	2.00	4.00	1.90	50.00	4.50	16.00	1.00	x
00784425	2.50	4.00	2.35	50.00	5.00	18.00	1.25	x
00784430	3.00	4.00	2.80	50.00	5.50	22.00	1.50	x

6 mm Shank, Long Neck

Item No.	D1 (mm)	D2 (mm)	D3 (mm)	L1 (mm)	L2 (mm)	L3 (mm)	R (mm)	CT
00782608	0.80	6.00	0.75	50.00	3.50	8.00	0.40	x
00782610	1.00	6.00	0.95	50.00	3.00	8.00	0.50	x
00782611	1.00	6.00	0.95	50.00	3.00	10.00	0.50	x
00782615	1.50	6.00	1.45	50.00	4.00	12.00	0.75	x
00782620	2.00	6.00	1.90	50.00	3.50	12.00	1.00	x
00782625	2.50	6.00	2.40	50.00	4.50	14.00	1.25	x
00782630	3.00	6.00	2.80	50.00	5.50	15.00	1.50	x
00782630L	3.00	6.00	2.80	50.00	5.50	17.00	1.50	x

6 mm Shank, Xtra Long Neck

Item No.	D1 (mm)	D2 (mm)	D3 (mm)	L1 (mm)	L2 (mm)	L3 (mm)	R (mm)	CT
00783610	1.00	6.00	0.95	50.00	3.00	12.00	0.50	x
00783615	1.50	6.00	1.45	50.00	4.00	16.00	0.75	x
00783620	2.00	6.00	1.90	50.00	3.50	16.00	1.00	x
00783625	2.50	6.00	2.40	50.00	4.50	18.00	1.25	x
00783630	3.00	6.00	2.80	50.00	5.50	22.00	1.50	x

Ball Nose End Mills, Conical, for Cobalt-Chrome/Titanium – coated

- End mill type:** Ball nose 180° bevelled pointed
- Number of flutes:** Two
- Versions:** Short
- Coating (CT):** X.CEED
- Features:** Voluminous and robust point with short effective length, therefore reduced risk of head fracture
- Indications:** Surfaces (fissures), edge machining, interdental spaces, internal machining (inside cavities)
- For users of:** DATRON, DMG, Mikron, imes-icore, Cobra Mill, Organical, Röders, Wieland, Wissner **and other systems.**

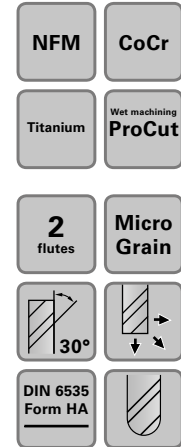
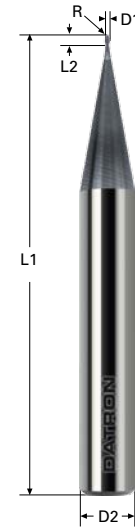

3 mm Shank

Item No.	D1 (mm)	D2 (mm)	L1 (mm)	L2 (mm)	R (mm)	CT
0078236K	0.60	3.00	48.00	1.50	0.30	x
0078238K	0.80	3.00	48.00	2.00	0.40	x
0078231K	1.00	3.00	48.00	2.50	0.50	x

6 mm Shank

Item No.	D1 (mm)	D2 (mm)	L1 (mm)	L2 (mm)	R (mm)	CT
0078266K	0.60	6.00	50.00	1.50	0.30	x
0078268K	0.80	6.00	50.00	2.00	0.40	x
0078261K	1.00	6.00	50.00	2.50	0.50	x

Spherical End Mills (Lollipop) for Cobalt-Chrome/Titanium – coated



End mill type: Spherical 270° (Lollipop)

Number of flutes: Two

Versions: Long

Coating (CT): X.CEED

Features: High machining options for undercuts, without having to tilt the workpiece

Indications: Undercut machining, outer contours, inner contours

For users of: DATRON, DMG, Mikron, imes-icore, Cobra Mill, Organical, Röders, Wieland, Wissner **and other systems.**



NFM	CoCr
Titanium	Wet machining ProCut
2 flutes	Micro Grain
DIN 6535 Form HA	

3 mm Shank

Item No.	D1 (mm)	D2 (mm)	D3 (mm)	L1 (mm)	L3 (mm)	R (mm)	Sphere (degrees)	CT
00785310	2.00	3.00	1.10	40.00	14.00	1.00	270	x

6 mm Shank

Item No.	D1 (mm)	D2 (mm)	D3 (mm)	L1 (mm)	L3 (mm)	R (mm)	Sphere (degrees)	CT
00785610	2.00	6.00	1.10	50.00	14.00	1.00	270	x

End Mills for Cobalt-Chrome / Titanium – coated

End mill type: End mill with sharp edge 90°

Number of flutes: Two

Versions: Long

Coating (CT): X.CEED

Features: Very sharp flutes, precise plane face machining, ideal for screw contact surfaces and/or contour machining

Indications: Bars, individual abutments, screwed-retained applications, interface connections (inside/outside), screw contact surfaces

For users of: DATRON, DMG, Mikron, imes-icore, Cobra Mill, Organical, Röders, Wieland, Wissner **and other systems.**

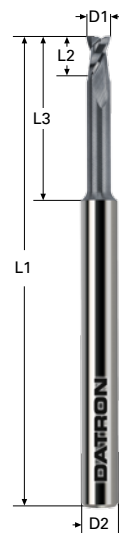

3 mm Shank Long Neck

Item No.	D1 (mm)	D2 (mm)	L1 (mm)	L2 (mm)	L3 (mm)	CT
0078004L	0.40	3.00	48.00	0.50	4.50	x
0078005L	0.50	3.00	48.00	0.60	5.00	x
0078008L	0.80	3.00	48.00	1.00	8.00	x
0078010L	1.00	3.00	48.00	1.20	15.00	x
0078012L	1.20	3.00	48.00	1.40	15.00	x
0078015L	1.50	3.00	48.00	1.80	16.00	x
0078018L	1.80	3.00	48.00	2.20	16.00	x
0078020L	2.00	3.00	48.00	2.40	16.00	x
0078025L	2.50	3.00	48.00	3.00	18.00	x

End Mills for Cobalt-Chrome / Titanium – coated

- End mill type:** End mill with sharp edge 90°
- Number of flutes:** Two
- Versions:** Short
- Coating (CT):** X.CEED
- Features:** Very sharp flutes, precise plane face machining, ideal for screw contact surfaces and/or contour machining Bars, individual abutments, screwed-retained applications, interface connections (inside/outside), screw contact surfaces
- Indications:** Bars, individual abutments, screwed-retained applications, interface connections (inside/outside), screw contact surfaces
- For users of:** DATRON, DMG, Mikron, imes-icore, Cobra Mill, Organical, Röders, Wieland, Wissner **and other systems.**

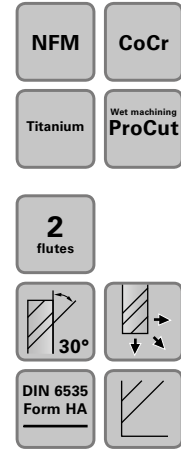
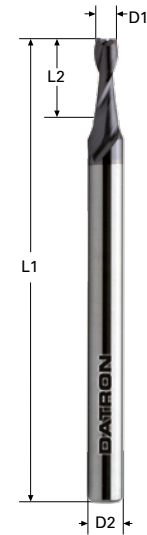

3 mm Shank, Short Neck

Item No.	D1 (mm)	D2 (mm)	L1 (mm)	L2 (mm)	CT
0078009K	0.90	3.00	38.00	1.80	x
0078010K	1.00	3.00	38.00	2.00	x
0078011K	1.10	3.00	38.00	2.20	x
0078012K	1.20	3.00	38.00	2.40	x
0078013K	1.30	3.00	38.00	2.60	x
0078014K	1.40	3.00	38.00	2.80	x
0078015K	1.50	3.00	38.00	3.00	x
0078016K	1.60	3.00	38.00	3.20	x
0078017K	1.70	3.00	38.00	3.40	x
0078018K	1.80	3.00	38.00	3.60	x
0078019K	1.90	3.00	38.00	4.00	x
0078020K	2.00	3.00	38.00	6.00	x
0078025K	2.50	3.00	38.00	7.00	x

End Mills for Cobalt-Chrome/Titanium with Weldon clamping surface (HB) – coated

- End mill type:** End mill with sharp edge 90°
- Number of flutes:** Four
- Versions:** Long
- Coating (CT):** Alcrona
- Features:** Sharp flutes, precise plane face machining, ideal for screw contact surfaces and/or contour machining
- Indications:** Bars, interface connections, contact surfaces
- For users of:** DATRON, DMG, Mikron, imes-icore, Cobra Mill, Organical, Röders, Wieland, Wissner **and other systems.**

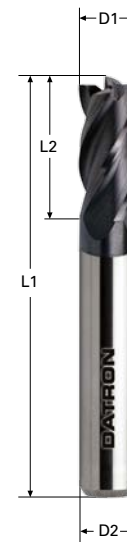

NFM	CoCr
Titanium	Wet machining ProCut
4 flutes	Micro Grain
30°	
DIN 6535 Form HB	

6 mm Shank, Short Neck

Item No.	D1 (mm)	D2 (mm)	L1 (mm)	L2 (mm)	CT
0078402	2.00	6.00	50.00	7.00	x
00784025	2.50	6.00	50.00	8.00	x
0078403	3.00	6.00	58.00	8.00	x
00784035	3.50	6.00	58.00	10.00	x
0078404	4.00	6.00	58.00	11.00	x

End Mills with Edge Radius for Cobalt-Chrome/Titanium – coated

End mill type: End mill with edge radius 90°

Number of flutes: Two

Versions: Long

Coating (CT): X.CEED

Features: Ideal as preliminary tool for screw channels

Indications: As a preliminary tool for all common indications. Apart from bars, individual abutments, screwed-retained applications, interface connections (inside/outside), screw contact surfaces

For users of: DATRON, DMG, Mikron, imes-icore, Cobra Mill, Organical, Röders, Wieland, Wissner **and other systems.**

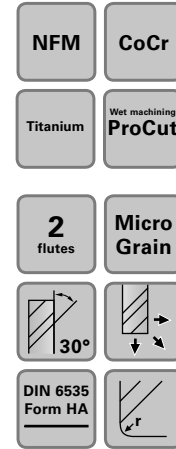
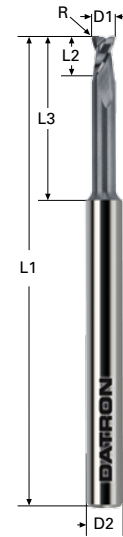

3 mm Shank Long Neck

Item No.	D1 (mm)	D2 (mm)	L1 (mm)	L2 (mm)	L3 (mm)	R (mm)	CT
0078010R	1.00	3.00	48.00	1.20	15.00	0.10	x
0078012R	1.20	3.00	48.00	1.40	15.00	0.10	x
0078015R	1.50	3.00	48.00	1.80	16.00	0.15	x
0078018R	1.80	3.00	48.00	2.20	16.00	0.18	x
0078020R	2.00	3.00	48.00	2.40	16.00	0.20	x
0078025R	2.50	3.00	48.00	3.00	18.00	0.25	x

End Mills for Cobalt-Chrome/Titanium – coated

- End mill type:** End mill with edge radius 90°
- Number of flutes:** Four
- Versions:** Long
- Coating (CT):** X.CEED
- Features:** Roughing tool with high chip volume, ideal as preliminary tool in order to achieve high material removal
- Indications:** As roughing or preliminary tool for all common indications
- For users of:** DATRON, DMG, Mikron, imes-icore, Cobra Mill, Organical, Röders, Wieland, Wissner **and other systems.**

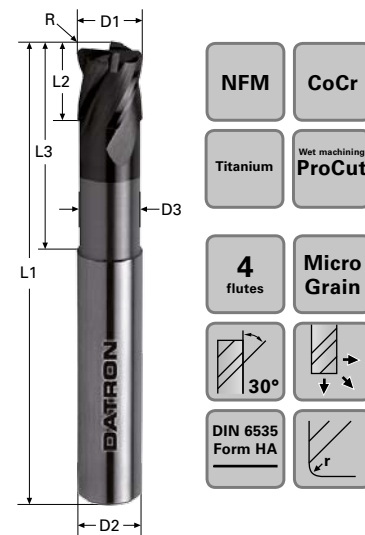

6 mm Shank, Long Neck

Item No.	D1 (mm)	D2 (mm)	D3 (mm)	L1 (mm)	L2 (mm)	L3 (mm)	R (mm)	CT
0078620	2.00	6.00	1.80	50.00	4.00	12.00	0.20	x
0078623	3.00	6.00	2.70	50.00	4.00	14.00	0.30	x
0078623A	3.00	6.00	2.70	50.00	4.00	18.00	0.30	x
0078624	4.00	6.00	3.70	50.00	5.00	16.00	0.40	x

End Mills w/Double Edge Radius for Cobalt-Chrome/Titanium – coated



- End mill type:** End mill with double edge radius 90°
- Number of flutes:** Four
- Versions:** Long
- Coating (CT):** X.CEED
- Features:** Roughing tool with high chip volume, ideal as preliminary tool in order to achieve high material removal. The double edge radius allows higher approach ramps. Less initial attrition
- Indications:** As roughing or preliminary tool for all common indications
- For users of:** DATRON, DMG, Mikron, imes-icore, Cobra Mill, Organical, Röders, Wieland, Wissner **and other systems.**



6 mm Shank, Long Neck

Item No.	D1 (mm)	D2 (mm)	D3 (mm)	L1 (mm)	L2 (mm)	L3 (mm)	R (mm)	CT
00786203	3.00	6.00	2.80	50.00	3.00	12.00	0.60	x
00786203A	3.00	6.00	2.80	50.00	3.00	16.00	0.60	x
00786204	4.00	6.00	3.80	50.00	4.00	14.00	0.80	x
00786204A	4.00	6.00	3.80	50.00	4.00	16.00	0.80	x

Centre Drills – uncoated

- End mill type:** Centre drills 140°
- Number of flutes:** Two
- Versions:** Short
- Coating (CT):** None
- Features:** Preliminary centring tool for drilling process, excluding shifting of the drill
- Indications:** All work requiring precise drilling
- For users of:** All milling systems admitting 3 mm Shanks.

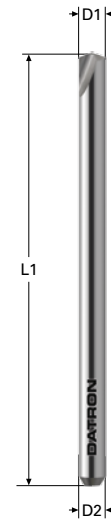

3 mm Shank

Item No.	D1 (mm)	D2 (mm)	L1 (mm)
0078701	1.00	3.00	48.00
0078702	2.00	3.00	48.00
0078703	3.00	3.00	48.00

Drills for Cobalt-Chrome / Titanium – coated



- End mill type:** Drills 155°
-
- Number of flutes:** Two
- Versions:** Long
- Coating (CT):** X.CEED
- Features:** High drill length, allows drilling through without need to turn the tool; alignment differences are therefore excluded
- Indications:** All work requiring precise drilling
- For users of:** All milling systems admitting 3 mm Shanks and drilling strategy or programming.

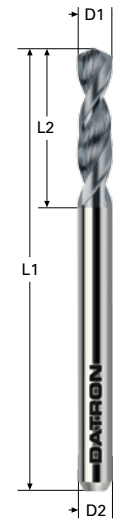

NFM	CoCr
Titan	Wet machining ProCut
2 flutes	Micro Grain
30°	↓
DIN 6535 Form HA	155°

3 mm Shank

Item No.	D1 (mm)	D2 (mm)	L1 (mm)	L2 (mm)	CT
0078708	0.80	3.00	48.00	7.00	x
0078709	0.90	3.00	48.00	9.00	x
0078710	1.00	3.00	48.00	11.00	x
0078711	1.10	3.00	48.00	11.00	x
0078712	1.20	3.00	48.00	13.00	x
00787125	1.25	3.00	48.00	13.00	x
0078713	1.30	3.00	48.00	13.00	x
0078714	1.40	3.00	48.00	15.00	x
0078715	1.50	3.00	48.00	16.00	x
0078716	1.60	3.00	48.00	16.00	x
0078717	1.70	3.00	48.00	16.00	x
0078718	1.80	3.00	48.00	17.00	x
0078719	1.90	3.00	48.00	17.00	x
0078720	2.00	3.00	48.00	20.00	x
0078722	2.25	3.00	48.00	20.00	x
0078725	2.50	3.00	48.00	20.00	x
0078727	2.75	3.00	48.00	20.00	x
0078730	3.00	3.00	48.00	20.00	x

CVD Diamond Single Flute End Mills for Cobalt-Chrome/Titanium

- End mill type:** Single flute end mill, diamond, 90°
- Number of flutes:** One
- Versions:** Short
- Coating (CT):** None
- Features:** The diamond single flute end mill is manufactured with a CVD process and is ideal for microscopically smooth and ultra fine surface finishing. Extremely high durability at low depths
- Indications:** Surface machining
- For users of:** DATRON, DMG, Mikron, imes-icore, Cobra Mill, Organical, Röders, Wieland, Wissner **and other systems.**

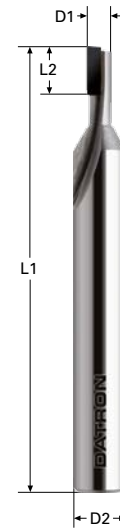

NFM	CoCr
Titanium	Wet machining ProCut
1 flute	CVD
0°	
DIN 6535 Form HA	

6 mm Shank

Item No.	D1 (mm)	D2 (mm)	L1 (mm)	L2 (mm)
00781203	3.00	6.00	50.00	5.00

Micro Ball Nose End Mills for PMMA/Wax – uncoated

- End mill type:** Micro ball nose 180°
- Number of flutes:** Two
- Versions:** Short
- Coating (CT):** None
- Features:** Stable micro-machining without adhesions in chip removal channels with low depth
- Indications:** Copings, crowns (anatomic, anatomically reduced), fissures, 3D free-form surfaces
- For users of:** BZT Dental, DATRON, DMG, Mikron, H-E-I-Z, imes-core, Laserdenta, Cobra Mill, Organical, RoboCAM, Röders, Roland, Wieland, Wissner and other systems.

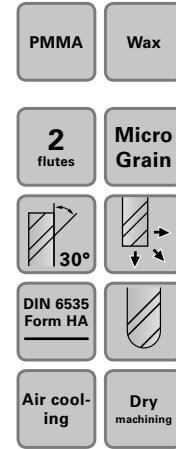
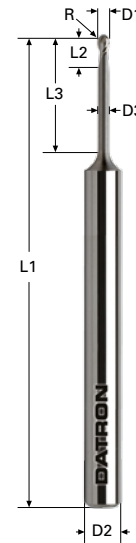

3 mm Shank, Short Neck

Item No.	D1 (mm)	D2 (mm)	D3 (mm)	L1 (mm)	L2 (mm)	L3 (mm)	R (mm)
00782004	0.40	3.00	0.35	40.00	0.60	2.00	0.20
00782005	0.50	3.00	0.45	40.00	0.75	4.00	0.25
00782005L	0.50	3.00	0.45	40.00	0.75	10.00	0.25
00782006	0.60	3.00	0.55	40.00	0.90	4.00	0.30
00782008	0.80	3.00	0.75	40.00	1.20	6.00	0.40
00782010	1.00	3.00	0.95	40.00	1.50	6.00	0.50
00782011	1.00	3.00	0.95	40.00	1.50	9.00	0.50
00782012	1.20	3.00	1.15	40.00	1.80	9.00	0.60
00782015	1.50	3.00	1.45	40.00	2.20	9.00	0.75
00782020	2.00	3.00	1.95	40.00	3.00	12.00	1.00

Ball Nose End Mills for PMMA/Wax – uncoated

- End mill type:** Ball nose 180°
- Number of flutes:** Two
- Versions:** Long
- Coating (CT):** None
- Features:** Polished flutes, burr-free and clean machining without adhesions in chip removal channels
- Indications:** Copings, crowns (anatomic, anatomically reduced), surface machining (fissures), short-term temporary dentures, 3D free-form surfaces

For users of: BZT Dental, DATRON, DMG, Mikron, H-E-I-Z, imes-icore, Laserdenta, Cobra Mill, Organical, RoboCAM, Röders, Roland, Wieland, Wissner, TDS, Yenadent **and other systems.**

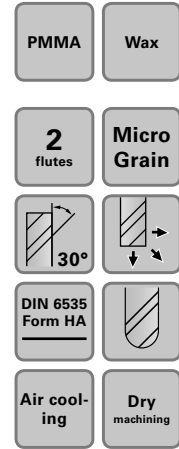
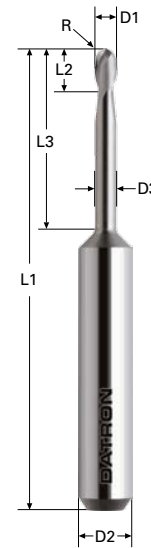

3 mm Shank, Long Neck

Item No.	D1 (mm)	D2 (mm)	D3 (mm)	L1 (mm)	L2 (mm)	L3 (mm)	R (mm)
00782406	0.60	3.00	0.55	48.00	2.50	10.00	0.30
00782408	0.80	3.00	0.75	48.00	3.50	12.00	0.40
00782410	1.00	3.00	0.95	48.00	4.00	16.00	0.50
00782415	1.50	3.00	1.45	48.00	4.50	18.00	0.75
00782420	2.00	3.00	1.95	48.00	5.50	20.00	1.00
00782425	2.50	3.00	2.40	48.00	6.00	25.00	1.25
00782430	3.00	3.00	2.80	48.00	6.00	25.00	1.50



4 mm Shank, Long Neck

Item No.	D1 (mm)	D2 (mm)	D3 (mm)	L1 (mm)	L2 (mm)	L3 (mm)	R (mm)
00783406	0.60	4.00	0.55	45.00	2.50	10.00	0.30
00783410	1.00	4.00	0.95	48.00	4.00	18.00	0.50
00783420	2.00	4.00	1.95	48.00	4.50	20.00	1.00
00783425	2.50	4.00	2.40	48.00	5.00	22.00	1.25

6 mm Shank, Long Neck

Item No.	D1 (mm)	D2 (mm)	D3 (mm)	L1 (mm)	L2 (mm)	L3 (mm)	R (mm)
00782906	0.60	6.00	0.55	50.00	2.50	10.00	0.30
00782908	0.80	6.00	0.75	50.00	3.00	12.00	0.40
00782910	1.00	6.00	0.95	50.00	4.00	16.00	0.50
00782915	1.50	6.00	1.45	50.00	4.00	18.00	0.75
00782920	2.00	6.00	1.95	50.00	4.50	20.00	1.00
00782925	2.50	6.00	2.40	50.00	5.00	25.00	1.25
00782930	3.00	6.00	2.90	50.00	6.00	25.00	1.50

Micro Ball Nose End Mills for Composites (High-Class) – coated

End mill type: Micro ball nose 180°

Number of flutes: Two

Versions: Short

Coating (CT): Alcrona

Features: Robust design due to short flutes

Indications: Fissures, 3D free-form surfaces

For users of: BZT Dental, DATRON, DMG, Mikron, H-E-I-Z, imes-icore, Laserdenta, Cobra Mill, Organical, RoboCAM, Röders, Roland, Wieland, Wissner **and other systems.**

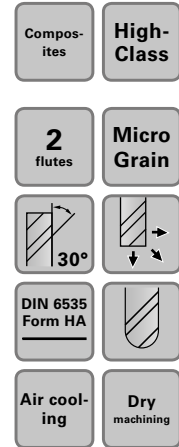
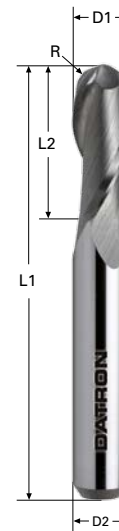

3 mm Shank, Short Neck

Item No.	D1 (mm)	D2 (mm)	L1 (mm)	L2 (mm)	R (mm)	CT
00684004	0.40	3.00	40.00	1.20	0.20	x
00684005	0.50	3.00	40.00	0.80	0.25	x
00684006	0.60	3.00	40.00	1.80	0.30	x
00684008	0.80	3.00	40.00	2.40	0.40	x

Ball Nose End Mills for Composites (High-Class) – coated



End mill type: Ball nose 180°

Number of flutes: Two

Versions: Long

Coating (CT): XTS

Features: High durability with strongly abrasive materials

Indications: Copings, crowns (anatomic), bridges, bars, individual Abutments, screwed-retained applications, short- and long-term temporary dentures, 3D free-form surfaces

For users of: BZT Dental, DATRON, DMG, Mikron, H-E-I-Z, imes-icore, Laserdenta, Cobra Mill, Organical, RoboCAM, Röders, Wieland, Wissner **and other systems.**

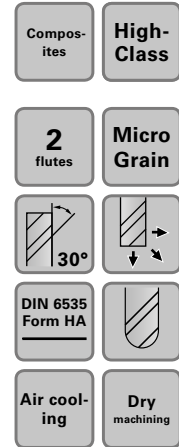
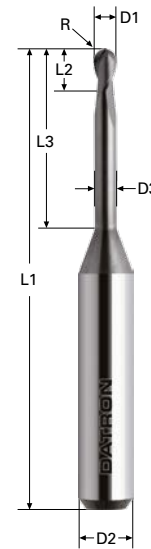

3 mm Shank, Long Neck

Item No.	D1 (mm)	D2 (mm)	D3 (mm)	L1 (mm)	L2 (mm)	L3 (mm)	R (mm)	CT
00782508	0.80	3.00	0.75	43.00	3.50	12.00	0.40	x
00782510	1.00	3.00	0.95	43.00	4.00	14.00	0.50	x
00782515	1.50	3.00	1.45	43.00	4.50	16.00	0.75	x
00782520	2.00	3.00	1.95	43.00	5.50	18.00	1.00	x
00782525	2.50	3.00	2.40	43.00	6.00	20.00	1.25	x
00782530	3.00	3.00	2.80	43.00	6.00	25.00	1.50	x

6 mm Shank, Long Neck

Item No.	D1 (mm)	D2 (mm)	D3 (mm)	L1 (mm)	L2 (mm)	L3 (mm)	R (mm)	CT
00783008	0.80	6.00	0.75	50.00	3.50	12.00	0.40	x
00783010	1.00	6.00	0.95	50.00	4.00	14.00	0.50	x
00783015	1.50	6.00	1.45	50.00	4.50	16.00	0.75	x
00783020	2.00	6.00	1.95	50.00	5.50	18.00	1.00	x
00783025	2.50	6.00	2.40	50.00	4.50	20.00	1.25	x
00783030	3.00	6.00	2.80	50.00	6.00	22.00	1.50	x

Ball Nose End Mills for Composites with Weldon Clamping Surface (HB) – coated

End mill type: Ball nose 180°

Number of flutes: Four

Versions: Long, Xtra Long

Coating (CT): Alcrona

Features: Roughing tool with high material removal when working with highly abrasive materials

Indications: As roughing or preliminary tool for all common indications, 3D free-form surfaces

For users of: DATRON, DMG, Mikron, imes-icore, Cobra Mill, Organical, Röders, KAVO, Wieland, Wissner and other systems.

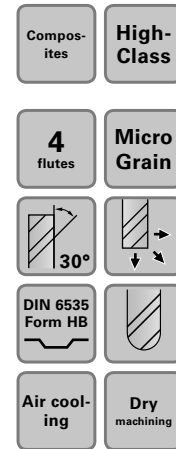

6 mm Shank, Long Neck

Item No.	D1 (mm)	D2 (mm)	L1 (mm)	L2 (mm)	R (mm)	CT
0078542	2.00	6.00	57.00	6.00	1.00	x
0078543	3.00	6.00	57.00	8.00	1.50	x
0078543A	3.00	6.00	57.00	20.00	1.50	x
0078543B	3.00	6.00	50.00	20.00	1.50	x
0078544	4.00	6.00	57.00	11.00	2.00	x
0078544A	4.00	6.00	50.00	20.00	2.00	x

Ball Nose End Mills for Composites with Weldon Clamping Surface (HB) – coated

End mill type: Ball nose 180°

Number of flutes: Two

Versions: Long

Coating (CT): XTS

Features: High durability with strongly abrasive materials

Indications: Copings, crowns (anatomic), bridges, bars, individual Abutments, screwed-retained applications, short- and long-term temporary dentures, 3D free-form surfaces

For users of: DATRON, DMG, Mikron, imes-icore, Cobra Mill, Organical, Röders, KAVO, Wieland, Wissner and other systems.

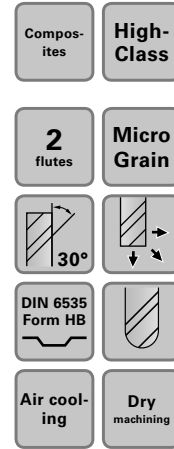
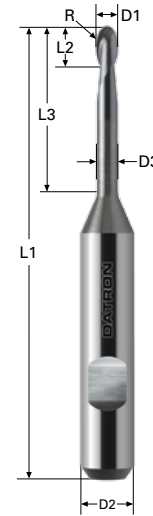

6 mm Shank, Long Neck

Item No.	D1 (mm)	D2 (mm)	D3 (mm)	L1 (mm)	L2 (mm)	L3 (mm)	R (mm)	CT
0073404	1.00	6.00	0.95	50.00	4.00	16.00	0.50	x
0073404A	1.00	6.00	0.95	50.00	4.00	19.00	0.50	x
0073404B	2.50	6.00	2.40	50.00	4.50	16.00	1.25	x
0073404C	2.50	6.00	2.40	50.00	4.50	19.00	1.25	x



Diamond Grinders, Sinterized for Disilicates

Tool type: Grinder

Number of flutes: None

Versions: 3 mm shank

Coating (CT): Diamond grain layer

Features: Sinterized grain layer, high durability, self-sharpening, lappable

Indications: All indications that can be manufactured using wet machining

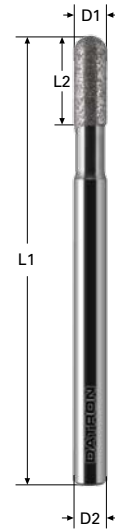

Glass ceramics



Micro Grain

DIN 6535 Form HA



Wet machining

3 mm Shank

Item No.	D1 (mm)	D2 (mm)	L1 (mm)	L2 (mm)	CT
0078336W	1.00	3.00	50.00	5.50	x
0078336V	1.20	3.00	50.00	3.00	x
0078336U	2.00	3.00	50.00	8.00	x
0078336T	3.00	3.00	50.00	8.00	x

Diamond Grinders for Disilicates



Tool type: Grinder

Number of flutes: None

Versions: 3 mm shank, D107

Coating (CT): Diamond grain layer

Features: Galvanised grain layer

Indications: All indications that can be manufactured using wet machining

For users of: DATRON D5 systems

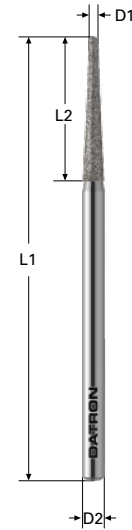

Glass ceramics



Micro Grain

DIN 6535 Form HA



Wet machining

3 mm Shank

Item No.	D1 (mm)	D2 (mm)	L1 (mm)	L2 (mm)	CT
0078336X	1.00	3.00	48.00	18.00	x

Ball Nose End Mills for Zirconium Oxide/PMMA/Wax – uncoated, for LAVA milling systems

- End mill type:** Ball nose 180° / end mill (Barcode Eraser) 90°
- Number of flutes:** Two
- Versions:** According to system requirements
- Coating (CT):** None
- Features:** High durability due to special solid carbide, sharp flutes
- Indications:** All machinable indications
- For users of:** LAVA CNC 240, 400 und 500 systems

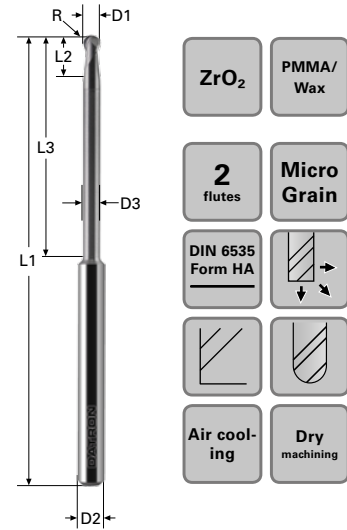

3 mm Shank

Item No.	Type	D1 (mm)	D2 (mm)	D3 (mm)	L1 (mm)	L2 (mm)	L3 (mm)	R (mm)
0078380B	1/2	2.00	3.00	1.95	50.00	2.00	25.00	1.00
0078380E	3	1.00	3.00	0.95	50.00	3.00	25.00	0.50
0078380A	4/5	2.00	3.00	1.60	38.00	2.00	16.00	1.00
0078380D	6	1.00	3.00	0.80	38.00	3.00	16.00	0.50
0078025	7	2.50	3.00		38.00	5.00		



Ball Nose End Mills for Zirconium Oxide – coated, for Charly Robot milling systems



- End mill type:** Ball nose 180° / end mill with 90° edge radius
- Number of flutes:** Two
- Versions:** According to system requirements
- Coating (CT):** Diamond
- Features:** High durability due to extreme diamond coating
- Indications:** All machinable indications
- For users of:** 2U, 4U, Charly Dental systems

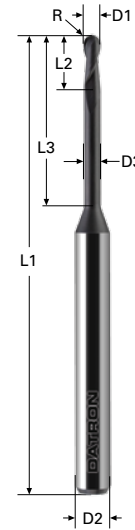

- ZrO₂
- 2 flutes
- Micro Grain
- DIN 6535 Form HA
- Air cooling
- Dry machining

3 mm Shank

Item No.	D1 (mm)	D2 (mm)	D3 (mm)	L1 (mm)	L2 (mm)	L3 (mm)	R (mm)	CT
00782005	0.50	3.00	0.45	40.00	0.75	4.00	0.25	
00782005L	0.50	3.00	0.45	40.00	0.75	10.00	0.25	
00782208A	0.80	3.00	0.75	38.00	3.50	13.00	0.40	x
00782210A	1.00	3.00	0.95	38.00	4.00	14.00	0.50	x
00782215A	1.50	3.00	1.40	38.00	4.00	14.00	0.75	x
00782333	3.00	3.00	2.70	38.00	4.00	14.00	0.30	x



Ball Nose End Mills for Zirconium Oxide – uncoated, for Cercon Brain Expert milling system

- End mill type:** Ball nose 180°
- Number of flutes:** Two
- Versions:** According to system requirements
- Coating (CT):** None
- Features:** High durability due to special solid carbide, sharp flutes
- Indications:** All machinable indications
- For users of:** Cercon Brain Expert systems.

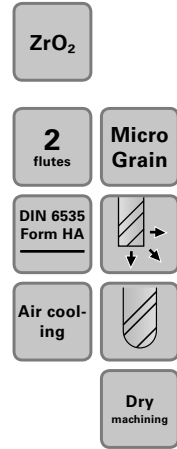

3,5 mm Shank

Item No.	D1 (mm)	D2 (mm)	D3 (mm)	L1 (mm)	L2 (mm)	L3 (mm)	R (mm)
0073380L	3.00	3.50	2.90	55.00	20.00	30.00	1.50
0073380K	2.00	3.50	1.90	55.00	10.00	20.00	1.00
0073380J	1.00	3.50	0.90	55.00	10.00	20.00	0.50



End Mills for PMMA/Wax – uncoated, for Cercon Brain Expert milling system

- End mill type:** Single flute end mill with ball nose 180°
- Number of flutes:** One
- Versions:** According to system requirements
- Coating (CT):** None
- Features:** High durability due to special solid carbide, sharp flutes
- Indications:** All machinable indications
- For users of:** Cercon Brain Expert systems.

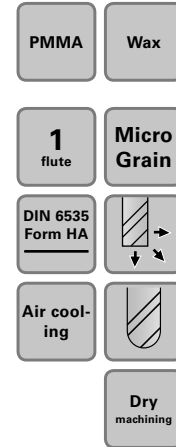
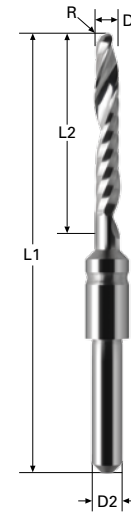

3,5 mm Shank

Item No.	D1 (mm)	D2 (mm)	L1 (mm)	L2 (mm)	R (mm)
0073380X	3.00	3.50	50.00	20.00	1.50
0073380Y	2.00	3.50	50.00	12.00	1.00
0073380Z	1.00	3.50	50.00	8.00	0.50



Ball Nose End Mills for ZrO₂, PMMA/Wax and High-Class – coated/uncoated for open KAVO milling systems

End mill type: Ball nose 180°

Number of flutes: Two

Versions: Short, Long

Coating (CT): Without, Diamond and XTS

Features: High durability, in part due to special solid carbide, in part due to extreme coatings

Indications: All machinable indications, 3D free form surfaces

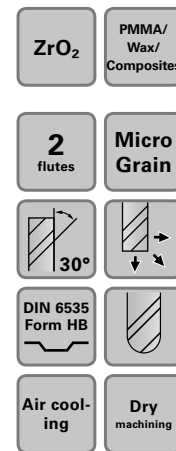

6 mm Shank, Short & Long Neck without Coating for PMMA/Wax

Item No.	D1 (mm)	D2 (mm)	D3 (mm)	L1 (mm)	L2 (mm)	L3 (mm)	R (mm)	CT
00782705A	0.50	6.00	0.40	48.00	1.00	2.50	0.25	
00782910A	1.00	6.00	0.90	54.00	1.50	16.00	0.50	
00782920A	2.00	6.00	1.90	54.00	3.00	20.00	1.00	

6 mm Shank, Long Neck with Diamond Coating for ZrO₂

Item No.	D1 (mm)	D2 (mm)	D3 (mm)	L1 (mm)	L2 (mm)	L3 (mm)	R (mm)	CT
00782807A	0.70	6.00	0.60	54.00	2.00	10.00	0.35	x
00782810A	1.00	6.00	0.90	54.00	1.50	18.00	0.50	x
00782820A	2.00	6.00	1.90	54.00	3.00	20.00	1.00	x

6 mm Shank, Long Neck with XTS Coating for High-Class

Item No.	D1 (mm)	D2 (mm)	D3 (mm)	L1 (mm)	L2 (mm)	L3 (mm)	R (mm)	CT
0073404	1.00	6.00	0.95	50.00	4.00	16.00	0.50	x
0073404A	1.00	6.00	0.95	50.00	4.00	19.00	0.50	x
0073404B	2.50	6.00	2.40	50.00	4.50	16.00	1.25	x
0073404C	2.50	6.00	2.40	50.00	4.50	19.00	1.25	x

Limit Stop Rings – for direct shank clamping systems

Some systems only have the ability to clamp milling tools directly into the rotating spindle. This is called direct shank clamping. Stop rings are necessary in these cases. By means of these rings, the length of the milling tool may be determined mechanically by the user outside of the spindle.

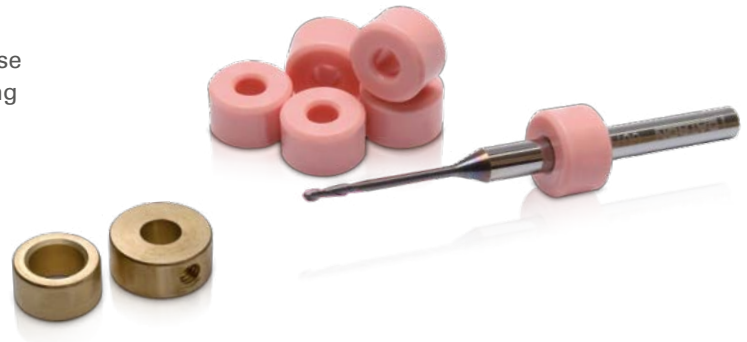

Item No.	D1 (mm)	D2 (mm)	Material
0068000	3.00	7.55	Synthetic
0068002	6.00	10.50	Brass*
0068002H	6.00	15.00	Brass*
0068002J	6.00	18.00	Brass*
0068000Y	4.00	10.50	Brass*

* all brass rings are reusable!

Insertion Tools for Limit Stop Rings

Insertion aids are necessary in order to fit stop rings accurately into milling tools. With the help of such equipment, you can always fit the right ring into the appropriate tool without difficulties. A plastic hammer is recommended to drive the rings home.

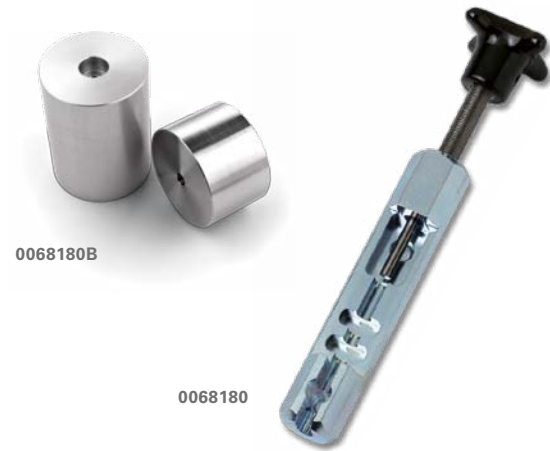

Item No.	Description
0068180B	Limit Stop Insertion Tool for 3 mm Shanks
0068180C	Limit Stop Insertion Tool for 4 mm and 6 mm Shanks*
0068180	Limit Stop Insertion Tool for 6 mm Shank Tools

User Instructions for Item No. 0068180C

Depending on the shank clamping length needed (see measure Lx in figure), the measure can be adjusted exactly with the help of the accompanying adjusting washers, allowing the ring to be driven home accordingly.

15 mm shank clamping length = receptacle + lid + adjusting washer 1 mm

20 mm shank clamping length = receptacle + lid + adjusting washer 4 mm and 2 mm

25 mm shank clamping length = receptacle + lid + all adjusting washers

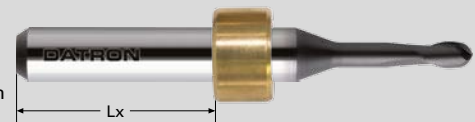

* The insertion tools consists of several parts (lower section, upper section, receptacle and adjusting washers). This allows you to drive the ring home effortlessly after measuring the correct distance.

DATRON Adapter Collets

DATRON's adapter collets allow using different tool shanks with a single spindle collet. For each tool in the changing station that has a different tool shank, an adapter collet is required. The adapters are reusable due to pre-clamping. An appropriate adapter insertion tool is required for defined opening.



Item No.	D1 (mm)	D2 (mm)
0068336	3.00	6.00
0068336I*	3.00	6.00
0068336C	3.00	8.00
0068350D	4.00	6.00
0068336D	4.00	8.00
0068337	Adapter insertion tool for 6 mm collets	
0068337A	Adapter insertion tool for 8 mm collets	

* Item 0068336I ist special for systems normally working with 6 mm shanks.
The outer ring has a 10,50 mm Ø and therefore fits inside the tool magazine of the machine.

Polygon HSK-E 25 Clamping Systems – for highest process reliability

HSK-E collets are designed for accurate and safe operation at high speeds. The precise concentricity of less than $3\ \mu\text{m}$ is an added bonus to promote the quality standard of individual tasks. Increased tool durability is guaranteed through the use of HSK-E inserts. A special clamping fixture is required to use HSK-E collets.



Item No.	D1 (mm)	D2 (mm)	Type	L1 (mm)	L2 (mm)
0068300G	3.00	20.00	HSK-E 25	40.00	25.00
0068300N	3.00	20.00	HSK-E 25 (vulcanised for wet machining)	40.00	25.00
0068301G	4.00	20.00	HSK-E 25	40.00	25.00
0068303G	6.00	20.00	HSK-E 25	40.00	25.00

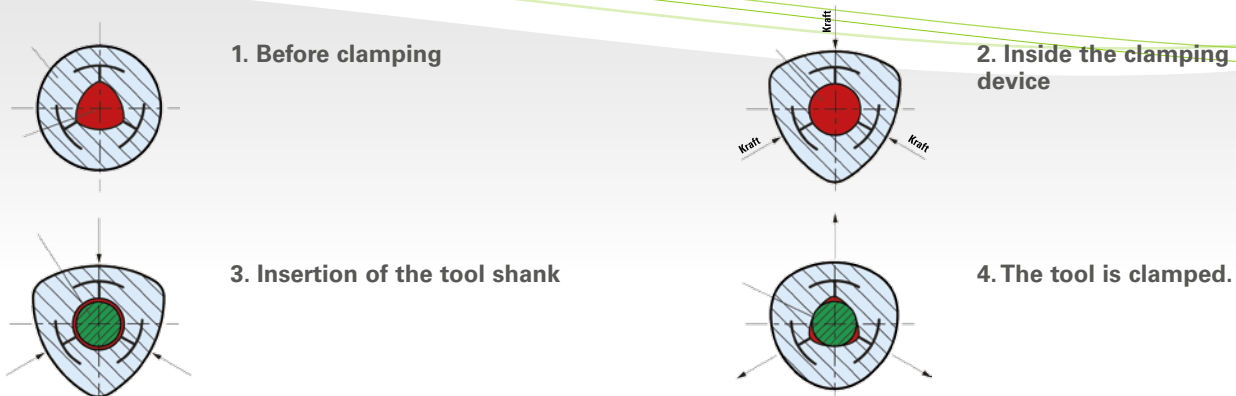

Lubricants and spindle additives

Lubricants/emulsions are essential for special machining of different materials. Durability of tool is highly increased with such media. Reduced spindle power consumption is responsible for further cost reductions, resulting from the reduction of cutting and friction forces between tool and workpiece.



Item No.	Description	Packaging
0069266B	DATRON ProCut 200	10 l
0069266D	DATRON ProCut 200	5 l
0069262Q	DATRON ProCut 280	10 l
0069266C	DATRON ProCut 280	2 l
0069266Y*	Betronol MFV 1463 F, Coolant additive for disilicate machining	1 l
0074923Y	Measuring cup for filling of Betronol	1 piece
0069260S*	Coolant additives	7 x 100 ml

* Attention: Please use only distilled water, because the effect of the coolant additives cannot be guaranteed otherwise.

0069260S: Consists of: biocide, corrosion protection, container, cover, safety data sheet, filling, dilution, packaging, cardboard packaging.

One package contains: 1 x AO-100 (100ml), 6 x B-100 (100ml). The quantity is sufficient for half a year.

AO-100 anti-oxidant: corrosion protection for all components traversed by the coolant

B-100 Biocide: prevents growth of germs and algae in the cooling circuit

Usage: Apply AO-100 every 6 months (at each change of coolant)

B-100 is to be used every 4 weeks (simply pour it into the coolant)

KERA-DISC Cobalt-Chrome Milling Blanks – by Eisenbacher



NPM-disc on cobalt basis/firing-capable

Non-precious metal milling blanks on CoCr basis, nickel and beryllium free. KERA-DISC features high corrosion resistance and biocompatibility and is fully laser-capable. The material is especially soft, excellent to machine and homogeneous due to a special heat treatment.



Item No.	D (mm)	t (mm)
0063900	98.50	8.00
0063901	98.50	10.00
0063902	98.50	12.00
0063903	98.50	13.50
0063904	98.50	15.00
0063905	98.50	18.00
0063906	98.50	20.00

Keralloy BioStar (CoCr) Milling Blanks – by SILADENT

Keralloy® BioStar is a nickel, cadmium, and beryllium free milling blank on CoCr basis. Keralloy® BioStar is produced in a powdering metallurgy sintering process and therefore has a much more homogeneous quality than conventionally cast CoCr blanks. Due to its special manufacturing process, Keralloy® BioStar can be machined significantly faster; tool durability increases by up to 50%.



Item No.	D (mm)	t (mm)
00781500	98.50	8.00
00781501	98.50	10.00
00781502	98.50	12.00
00781503	98.50	13.50
00781504	98.50	15.00
00781505	98.50	18.00
00781506	98.50	20.00

TITANIUM BioStar Grade 2/4 Milling Blanks– by SILADENT

TITAN BioStar is made of biocompatible pure grade 2 titanium according to DIN ISO 5832-2. The milling blanks are suitable for crowns and bridges, unalloyed or alloyed with ceramics for telescopic and double crowns, precision attachments for implant-supported supra-constructions.

In addition to the indications for TITAN BioStar °2, TITAN BioStar °4 is especially suitable for bar constructions and for the production of individual abutments in combination with implants, which are usually also made of titanium grade 4.



Grade 2

Item No.	D (mm)	t (mm)
00781600	98.50	8.00
00781601	98.50	10.00
00781602	98.50	12.00
00781603	98.50	13.50
00781604	98.50	15.00
00781605	98.50	18.00
00781606	98.50	20.00

Grade 4

Item No.	D (mm)	t (mm)
00781700	98.50	8.00
00781701	98.50	10.00
00781702	98.50	12.00
00781703	98.50	13.50
00781704	98.50	15.00
00781705	98.50	18.00
00781706	98.50	20.00

TITANIUM Grade 5 ZENOTECTi Milling Blanks— by Wieland

ZENOTECTi provides a high-quality titanium alloy (Ti Al6V4). The Grade 5 alloy has outstanding mechanical properties, so that even bridges with up to 16 links can be manufactured. The material has also proved its excellent biocompatibility: it has been successfully used for years in hip implants or in dental implant superstructures.



Item No.	D (mm)	t (mm)
0063945	98.5	8.00
0063946	98.5	10.00
0063947	98.5	12.00
0063948	98.5	13.50
0063949	98.5	15.00



Accessories for DATRON D5 milling/grinding machine

In order to profit always from the full benefits of the DATRON D5, there are some essential accessories and wear parts. This is the only way to keep the added value of your machine at a constant high operative level.



0198088



0198901



0A34103

DATRON D5 Blank Holders and Accessories

Item No.	Description
0A34103	Blank holder (unit for clamping blanks)
0071604P	Mounting screws for blank holder 0A34103
07020358	Upper distance ring (necessary when using 8 mm blanks)
07014981	Spacer ring (necessary when using 8 mm blanks)
0069890A	Clamping ring black*
0069890B	Clamping ring red*
07020847	Clamping ring yellow*
0198088	Torque Screwdriver
0198901	Quick measuring gauge T-59113 (Fino High Praeci Caliper)

* Rubber rings lose shape and elasticity over time. Therefore it is necessary to replace clamping rings consistently every 3 months or after 100h of operation with new ones, regardless of their hours of operation. Constant clamping or frequent loading and unloading of the rings, as well as contact with strong cleaning agents, lead to their instability and therefore, the impossibility of their being used further.



0A34104

DATRON D5 Accessories for Wet Machining

Item No.	Description
0A34104	Holder for e.Max block (disilicate)
0198030	Allen wrench (for e.Max holder locking screw)
0071601A	Locking screw for e.Max holder
0069995B	Filter insert for emulsion-collecting container, 1 pack = 6 pieces

Accessories for DATRON D5/Dental Machine Environment

Machine vacuum cleaners are available in various performance classes and are only used for dry machining of common dental materials. The given suction power is fully kept up to a distance of 6 metres. These vacuum cleaners come complete and are directly applicable. The necessary collection tray and connection tube are included.

The fully automatic fire extinguishing system can be purchased directly with the milling machine or as a retrofit option. It is essential when the milling system machines titanium without operator or supervision, for example in case of night operation. The extinguishing system includes including an extinguishing system control FB703, a safety cabinet for argon extinguishing media containers and a butterfly flame protection valve.



DATRON - Vacuum Cleaners

Item No.	Description
0A32204	Machine vacuum cleaner type RE115 including CEE three-phase contactor (performance: 1,220 m ³ /h, 18 mbar vacuum, 120 mm Ø supply cable)
0A32202	Machine vacuum cleaner type RE120 including CEE three-phase contactor (performance: 1.170 m ³ /h, 36 mbar vacuum, 120 mm Ø supply cable)

DATRON D5 - Extinguishing System for Unmanned Titanium machining

Item No.	Description
0A34010	D5-extinguishing system including installation, putting into operation and training

DATRON D5 - Weight Balance Platform

Item No.	Description
0A34105	Special professional weight balance platform for D5 system (WxHxD: 795 mm x 1120 mm x 15 mm)

Accessories for DATRON D5 Milling/Grinding Machine – cleaning and maintenance



In order to profit always from the full benefits of the DATRON D5, there are some essential accessories and wear parts. This is the only way to keep the added value of your machine constantly operating at a high level.



DATRON D5 Cleaning Accessories

Item No.	Description
0068338H	Cleaning pin for spindle
00695046	Cleaning set (contains 0069659A/ B/ C)
0069659A	Dust brush, short, without handle
0069659B	Dust brush, long, with handle
0069659C	Dust brush, angled, long, with handle

DATRON D5 Maintenance Accessories

Item No.	Description
0074921E	Hand lever grease gun, 500 ml, with "Dynalub 510" cartridge
0077107Z	Dynalub 510 high-performance grease, 400 g cartridge

Accessories for DATRON Dental Milling Machine



In order to profit always from the full benefits of the DATRON D5, there are some essential accessories and wear parts. This is the only way to keep the added value of your machine constantly operating at a high level.



DATRON Dental Blank Holders and Accessories

Item No.	Description
0694221B	Blank holder (Blank clamping unit)
0071605B	Blank holder fastening screws
0069220	Tool change station for 3 mm
0069221	Tool change station for 6 mm

DATRON Dental Cleaning Accessories

Item No.	Description
0068338H	Cleaning pin for spindle
00695046	Cleaning set (contains 0069659A/ B/ C)
0069659A	Dust brush, short, without handle
0069659B	Dust brush, long, with handle
0069659C	Dust brush, angled, long, with handle

DATRON CAM-Software – WorkNC by Sescoi



WorkNC® DENTAL includes a comprehensive range of automatic and interactive procedures that support the user in the preparation of the components - from selecting the blank through the addition of supports to the start of the production process.



Item No.	Description
0A32707C	Template from existing template pool
0A32707H	Specially developed customer template (tailor-made)
0A32707F	Two additional templates
0A32707G	Five additional templates

DATRON CAM-Software – hyperDENT by Follow Me!

“hyperDENT” is a fully automatic programming system for efficient and easy manufacturing of crown and bridge structures. The user is guided through the entire programming process. With its intuitive user interface with many practical functions, “hyperDENT” provides for time- and cost-saving operation.



Item No.	Description
0A32708B	Template from existing template pool
0A32708C	Template package hyperDENT (4 for the price of 3)
0A32708D	Specially developed customer template (tailor-made)

DATRON Scanners and Accessories – Imetric

Dental scanner with strip light technology

An absolute must when accuracy is important. This scanner is completely ergonomic to use and combines features such as Multi-Form scanning, allowing the construction process to be continued while other models are still being scanned.

Whether for a simple dental impression, big-scale work or an individual implant abutment, the Imetric scanning solution provides unmatched quality and precision.



Item No.	Description
0A32726	Imetric Scanner D103 including PC + Monitor, exocad Software, without libraries for crowns and bridges
0A32726A	Imetric Scanner D103a including PC + Monitor, exocad Software for individual abutments and implant module
0A32726B	Imetric Scanner D103i including PC + Monitor, exocad Software for screwable bars/ supra structures + implant module
0A32726M	Virtual articulator
0A32726X	Training per day, travel costs (time + expenses) excluded

DATRON Scanners and Accessories – 3shape



3shape 's advanced dental scanners are so easy to use that it is hardly necessary to train the staff. The attachment of the objects is quick and it takes just a single click on the user-friendly interface to start scanning.



Item No.	Description
0A32723	D700 Series* including Dental & Abutment Designer and 1 day of training (Fee 1.500,00 € + 450,00 €)
0A32723A	D710 Series* including Dental & Abutment Designer and 1 day of training, but Multi-Die capable with Multi-Die plate (Fee 1.500,00 € + 450,00 €)
0A32723B	D800 Series* ncluding Dental & Abutment Designer and 1 day of training, equipment as D710, but with greater precision (Fee 1.500,00 € + 450,00 €)
0A32723C	D810 Series* including Dental & Abutment Designer and 1 day of training (Fee1.500,00 € + 450,00 €)
0A01901M	Training per day, travel costs (time + expenses) excluded
0A32723X	Training per day at Tiemziereis

- * Training takes place at DATRON's partner Teamziereis, in 75331 Engelsbrand. Current cost of 3shape annual license fee (starting the first year)
- for software updates of the Dental Designer, 1.500,00 €
- for the Abutment Designer, 450,00 €
including PC with keyboard and mouse, without monitor

DATRON Scanners and Accessories – dental wings



The 3Series is a compact and affordable scanning and design solution that is ideal for small and medium-sized dental laboratories. Powered by DWOS, the 3Series scanner offers a complete platform, which is particularly suitable for the outsourcing business model, or in combination with a free in-house milling system. The 3Series is currently the fastest growing and most widely used scanning system on the market.



Item No.	Description
0A32724	Dental Wings 3Series including implant module and axis finder + TFT monitor, keyboard and mouse (Fee 1,200,00 €/year for crowns and bridges, 300,00 €/year for implant module)
0A32724X	Training per day, travel costs (time + expenses) excluded

DATRON Sintering Furnaces – mihm-vogt, DEKEMA



mihm-vogt

Speed-Sintering Furnace for Zirconium Oxide HT

Type HT was developed for sintering zirconium oxide ceramics. The microprocessor based electronic programme controller, allows the use of all ceramics to be found on the market.

DEKEMA

AUSTROMAT Series for Zirconium Oxide

Efficient and robust AUSTROMAT baSiC and μ SiC high-temperature furnaces with heating elements made of silicon carbide for sintering temperatures up to 1.560 ° and 1.600 °.



mihm-vogt

Item No.	Description
0A32210	High temperature sintering furnace HT
0A32210X	Training per day, travel costs (time + expenses) excluded

DEKEMA

Item No.	Description
0A32211*	Austromat baSiC high temperature sintering furnace up to 1.560 °C
0A32211A**	Austromat μ SiC high temperature sintering furnace up to 1.600 °C

* Delivery contents: AUSTROMAT baSiC, USB terminal, user manual, high temperature sintering furnace for sintering up to 1.560 °C complete with Ethernet and USB interface, X-DREAM

** Delivery contents: AUSTROMAT μ SiC, Multicompound isolated table, USB terminal, user manual, high temperature sintering furnace for sintering up to 1.600 °C, complete with starter set for 3-level sintering with Ethernet and USB interface, X-DREAM

DATRON D5 – the compact milling/grinding machine¹!

The DATRON D5 is a high-performance milling-grinding machine¹ especially developed for use in dental applications with the smallest footprint.

Its advantages at a glance:

- 5-axis simultaneous machining
- Extremely short production times
- Very compact: only 79 cm wide
- Easy operation using Apple iPad
- Integrated 8-fold blank changer
- 13-fold tool changer with length sensor and breakage monitoring
- For highly complex indications such as: implant work, bar construction, individual abutments and telescopes

Further information at:
www.dental.datron.de

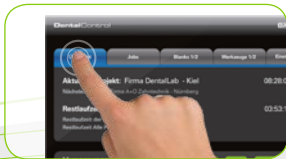

¹ with "wet machining" option



reddot design award
winner 2010



Designpreis
Deutschland
2011

NOMINIERT

DATRON D5 Service – completely worry-free production!

Our Services

- Service Hot Line: +49 (0)6151-1419-99
- Putting into operation and on-site repairs
- Decentralised service centres
- Spare parts shipment with high availability of parts, usually delivered within 24 hours.
- Maintenance and machine overhauls
- Software updates and upgrades
- Logistic support
- Remote maintenance
- On-site process support
- Warranty extension



DATRON Maintenance Contract

An individually tailored maintenance contract will help you to reach your production goals safely and reliably.

- Maintenance at a fixed price
- Response times: on weekdays within 24 hours on-site
- Increased machine availability
- Machine precision check
- 15% discount on current travel and hourly rates
- Increased Hot Line availability (Monday to Friday, 7 am - 7 pm, Saturday 9 am - 3 pm)
- **Fixed price: 656,00 € per maintenance service** plus travel costs and required materials
- Your price advantage: 160,00 € per maintenance service compared to standard maintenance services without contract

DATRON Machine Check

We take care of (almost) everything!

A periodical function check increases the availability of your machine system. We offer a monthly function check of your DATRON dental milling machine by our specialised staff.

The function check includes:

- Automation (blank magazine, workpiece handling, etc.)
- Tool changer positions
- Vacuum-cleaning
- High frequency spindle
- Cooling/lubricating system
- Machine geometry and accuracy

The monthly amount of work represents approximately 2.5 hours at a **fixed price of 250,00 €** plus travel costs and expenses.

DATRON Dental – used and demo machines

Their highly precise construction and their modular concept have been especially designed for the increasing demands of the dental CAD/CAM technology.

The massive granite structure allows very dynamic and time-saving milling, while keeping high quality at the same time.

DATRON dental milling systems are available in several configuration levels, so that they can grow according to your requirements and your success. The top model “Dental-C” offers:

- 5-axis precision machining
- Highest precision, compact measurements
- Flow-optimised vacuum cleaning design for zirconium machining
- Minimum quantity cooling for especially long tool durability when machining metals
- 8-fold integrated automation (optional)
- HSK-E 25 Spindle with up to 50,000 rpm
- 20-fold automated HSK-E 25 tool changer

You can find more information on available used and demo machines at:

www.dental.datron.de



Your DATRON Dental Team – we introduce ourselves!

Competent, friendly, helpful and flexible.

This is the DATRON DentalTeam, which is happy to help and advise you in all matters concerning our technology.

DATRON Dental Milling Tools



Claudio Jorio

DentalTools
National/International

Tel.: +49 (0) 61 51- 14 19 - 480
Email: claudio.jorio@datron.de



Handan Bayraktar

CNCTools/DentalTools
Customer Centre

Tel.: +49 (0) 61 51 - 14 19 - 89
Email: mini-tools@datron.de



Pierre Laqua

CNCTools/DentalTools
Customer Centre

Tel.: +49 (0) 61 51 - 14 19 - 57
Email: mini-tools@datron.de

DATRON Dental Milling Machines



Dirk Iller

Customer Advice and Sales
Germany, Austria, Switzerland

Tel.: +49 (0) 61 51- 14 19 - 55
Email: dirk.iller@datron.de



Andreas Schmidt

Customer Advice and Sales
International

Tel.: +49 (0) 61 51 - 14 19 - 438
Email: andreas.schmidt@datron.de



Claudio Jorio

Customer Advice and Sales
International

Tel.: +49 (0) 61 51 - 14 19 - 480
Email: claudio.jorio@datron.de

Dental Applications Team:

You can reach us at: 06151-1419-186 or via email: dental_application@datron.de



Rupert Flögel

Product Manager
CAD/CAM



Florian Maier

Technology Advice



Rouven Schwab

Technology Advice



Eric Rintelen

Technology Advice



Christian Schuchmann

Technology Advice

Dental Service Team:

You can reach us at: 06151-1419-99 or via email: service@datron.de



Johannes Hoeft

Team Leader Dental
Service Hotline



Werner Krupp

On-site Service



Kevin Kämmerer

On-site Service

Calculation Parameters/Standards – Formulae for calculation of milling parameters

Formula	Parameter
Cutting speed $V_c = \frac{\pi * d * n}{1000}$	Vc = Cutting speed (mm/min) d = Tool diameter (mm) n = Number of revolutions (rpm)
Feed speed $V_f = f_n * n * z$	vf = Feed speed (mm/min) fz = Tooth feed (mm/min) n = Number of revolutions (rpm) z = Number of teeth (-)
Cutting capacity $P_c = \frac{Q}{V_{sp}}$	Pc = Cutting capacity (kW) Q = Chip volume per time unit (cm ³ /min) Vsp = Special chip volume per time unit (cm ³ /min/kW)
Chip volume per time unit $P_c = a_e * a_p * v_f$	Q = Chip volume per time unit (cm ³ /min) ae = radial working engagement (mm) ap = Cutting depth (mm) vf = Feed speed (mm/min)

Cutting speed and feed rate are probably the most important factors in machining, as these parameters strongly influence production time. Cutting speed means the speed with which the rotating tool moves directly on its flutes through the workpiece, the dental prosthesis, removing a chip. It is expressed typically in metres per minute. The choice of the cutting speed depends largely on the composition and strength of the material to be machined, the toughness and hardness of the milling tool and the required and desired dimensional accuracy and surface finish. The higher the cutting speed, the smoother and finer the machined surface. However, in parallel with increasing cutting speeds, the wear of the used milling tool also grows.

FAX-Order –

copy, fill in, fax!

+49 (0) 61 51 - 14 19 - 39

Company stamp

Contact person

Customer number

Billing address

Shipping address

Item No.	Item Description	Unit Price	Quantity	Final Price
			Subtotal:	
			VAT:	
			Total:	

Date, Signature

Delivery and Payment Terms for Tool Deliveries
 Prices are ex-works, excluding VAT, packaging, freight and insurance. For orders below 50.00 € net, we charge a minor quantity surcharge of 15.00 €. For orders above 50.00 € we deliver free of charge. For orders within Germany for up to 50.00 € we charge a packing and shipping fee of 9.00 €. Shipping to foreign countries is charged at cost. Fees for foreign payments must be borne by the customer. We request your payment within 14 days from invoice date with 2% discount or within 30 days net. These special terms apply only to tool deliveries. Deliveries from the rest of our product range are specifically excluded from these special terms. Our offers and deliveries are subject to our "General Delivery and Payment Terms and Conditions.

Your Notes

A series of horizontal green lines for writing notes on a white background. The lines are evenly spaced and extend across the width of the page. There are 25 lines in total, starting from the top of the page and ending near the bottom. The lines are a light green color, matching the header. The page has a white background with a green header and footer. The footer contains the number 78.

A page with a solid green header at the top. The main body is white and contains 20 horizontal green lines for writing. Below this, there is a decorative wave graphic with a light blue-grey gradient. Underneath the wave, there is a grey rectangular area containing 8 horizontal green lines for writing. The footer is a solid green bar at the bottom right corner.

www.dentalfraeser.datron.de



Order now:

Ordering hot line: **+49 (0) 61 51 - 14 19 - 111**

Tool Support: **+49 (0) 61 51 - 14 19 - 480**



Fax:

+49 (0) 61 51 - 14 19 - 39



E-Mail

mini-tools@datron.de

© 2012 DATRON AG - Price list as of May 2012

All information in this brochure refers to current descriptions or features which may change owing to further product development. Descriptions and characteristics are only binding if expressly agreed on in writing at contract conclusion. All prices shown in this catalogue are net retail prices.

Apple, the Apple logo and iPad are registered trademarks or trademarks of Apple Inc. All other company and product names may be trademarks of the respective companies with which they are associated.

DATRON AG
In den Gänsäckern 5
D-64367 Mühlital

Tel.: **+49 (0) 61 51 - 14 19 - 0**
Fax: **+49 (0) 61 51 - 14 19 - 69**
www.datron.de