

STEPPER MOTORS
IP STEPPER MOTORS
HOLLOW SHAFT MOTORS
BRUSHLESS DC MOTORS
BRUSHLESS DC MOTORS IP65
LINEAR ACTUATORS
PLUG & DRIVE MOTORS
MOTOR CONTROLLERS
ENCODERS / GEARS / BRAKES

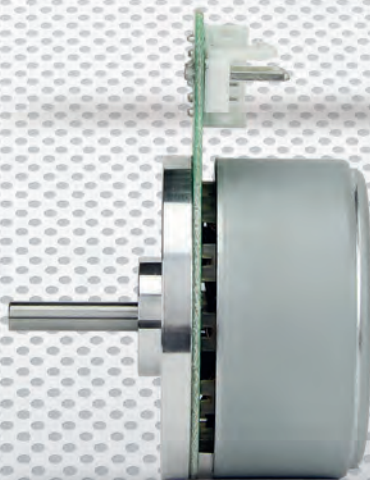

The company

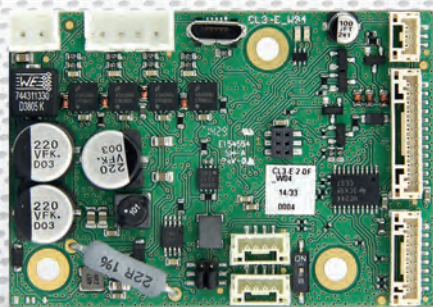
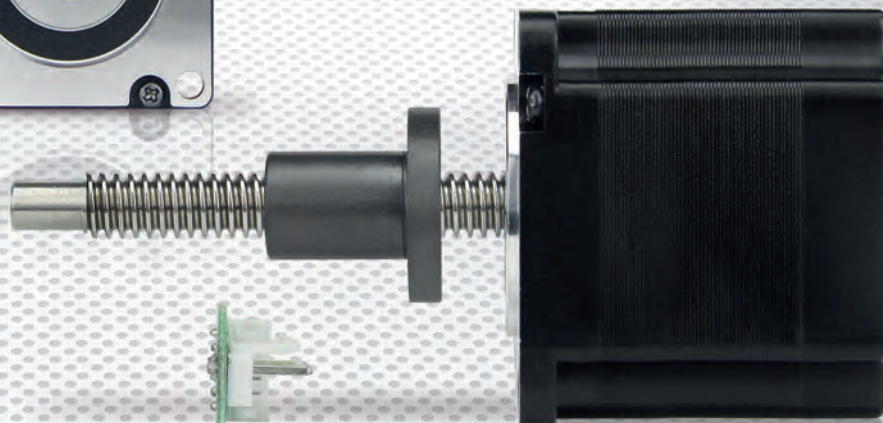
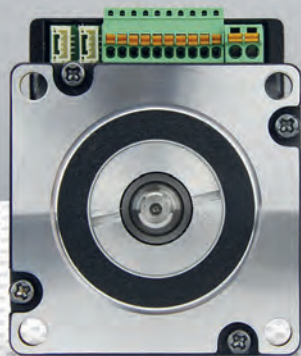
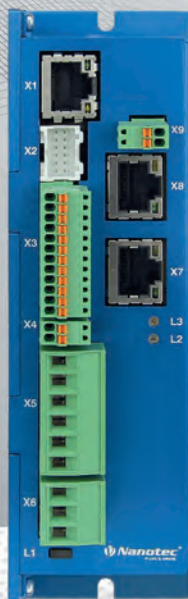

Nanotec Electronic GmbH & Co. KG, headquartered in Feldkirchen near Munich, is among the world's leading manufacturers of motors and motor controllers for high-quality drive solutions. The company has been developing and marketing a broad range of products since 1991. Nanotec technology is primarily used in automation systems, automatic laboratory equipment, medical devices and semi-conductor production.

Early on, company founder Benno Wimmer recognized that power electronics are at the heart of efficient and effective drives and pushed the development of motor controllers. In 1996, Nanotec came out with the first Plug & Drive motor with an integrated controller, thereby setting a cornerstone that would ultimately be central to the company's growth.

Still today, Nanotec focuses heavily on research and development to create drive solutions that closely meet the needs and requirements of our customers. The hardware and software used in motor controllers, sensors, and customized applications are developed at the Feldkirchen headquarters, while innovations for our next product generation emerge from the R&D center in Pegnitz.

Together with subsidiaries in Changzhou, China, and Medford (Massachusetts), USA, and more than 20 sales partners, we provide Nanotec drive solutions and expert technical support to customers all over the world.

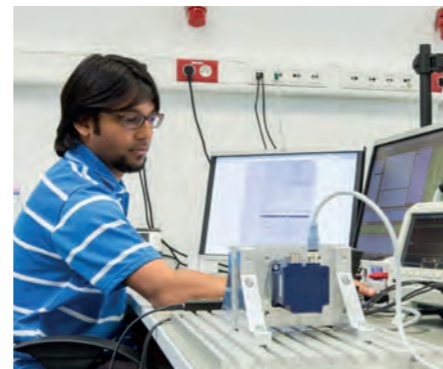

Standard and custom solutions for optimum drives

When drive systems with high precision, reliability and extensive functionality are required to fit in small spaces, Nanotec supplies the necessary technology – either as standard solutions or individualized designs. With prototype construction and the production of customized assemblies still located in Germany, and due to our policy of extensive warehousing, we are able to respond quickly and flexibly to customer needs.

Our stepper and BLDC motors, linear actuators and linear positioning drives, in sizes beginning at 10 mm, together with a variety of gears and encoders, are combine into a modular system with over 4000 possible combinations. In addition, you can choose from a range of shaft, flange and connector types that rapidly and reliably connect to existing device architecture.

Finally, the performance and resonance behavior of Nanotec motors is optimized by intelligent motor controllers that meet the latest technology standards.



Our products are manufactured at two Nanotec plants in China. Fully trained employees and high-quality machinery ensure stable processes and a high in-house production depth. Both production facilities in China operate according to German quality standards and are ISO-certified.

By controlling and monitoring all stages of manufacture – from prototype construction to pre-series and final production – Nanotec is able to quickly and efficiently produce customized solutions in series production.



Our integrated management system



Nanotec relies on an integrated management system that takes effect in the areas of quality, environment, occupational health and safety, risk management and data protection.

This system is designed to secure the continuing success of the company by guaranteeing our ability to promptly and efficiently meet customer needs and expectations while keeping our environmental impact to a minimum. By doing so, it lays the foundation for high quality standards and continuous improvement.

Nanotec quality assurance and environmental protection policies are in line with ISO 9001:2008 and ISO 14001:2004. Our occupational health and safety standards are designed according to the OHRIS concept and have been certified since 2014.

As part of our corporate policies and guidelines, we consider it our duty to ensure the viability of our company over the long term. Well-trained and responsible employees, a forward-looking personnel policy and a positive corporate culture all contribute to this aim. We adhere to pertinent national and international quality standards, integrate suppliers and customers in decision-making processes, detect and assess errors and risks at an early stage, and regularly reevaluate and update our goals.



Worldwide sales network



Nanotec products are available both directly from us and via a worldwide network of sales partners. A list of our sales partners can be found on our website.

Our complete range of products can be found at www.nanotec.com

Quick and easy online shopping for the right product:

- Order quantities of up to 25 pieces directly on our website
- Our motor wizard will help you find a suitable motor
- Product configurator: Just a few clicks to configure your individual motor combination with encoder, brake and gear
- Free access to datasheets and 3D-data
- Torque curves of all motors at different operating voltages and control modes



COMPANY	4	LINEAR ACTUATORS	101
STEPPER MOTORS	11	LS28	114
SP0618 - SP5575	14	L35	116
ST2018	24	L35-A	118
ST2818	26	LS35	120
STF2818	28	L41	122
ST3518	30	L41-A	126
ST4118	32	LS41	130
ST4209	38	L59	132
ST5909	42	L59-A	134
ST5918	44	LS59	136
ST6018	48	PLUG & DRIVE MOTORS	138
ST6318	52	PD2-O41	144
ST8918	54	PD2-N41	146
ST11018	56	PD4-N5918/N6018	148
SC4118	58	PD4-C	152
SC6018	60	PD4-CB	156
IP STEPPER MOTORS	63	PD6-N89	158
AS2818	64	PD2-N4118-IP	162
AS4118	66	PD4-N5918/N6018-IP	164
AS5918	70	MOTOR CONTROLLERS	169
AS8918	74	SMC11	170
AP8918	76	SMC112	172
HOLLOW SHAFT MOTORS	79	SMCP33	174
ST4118	80	SMCI33	176
ST5918	81	SMCI35	178
BRUSHLESS DC MOTORS	83	SMCI36	180
DB22	85	SMCI47-S	182
DB28	86	NP5	184
DB33	87	N5	186
DB42	88	C5	188
DB57	90	C5-E	190
DB59	91	CL3-E	192
DB87	92	OPTIONS	194
DF45	94	Modular motor configuration system	195
BRUSHLESS DC MOTORS IN PROTECTION CLASS IP65	97	Shaft Machining	196
ASB42	98	Cable Assembly	198
ASB87	99	Encoder	200
LINEAR ACTUATORS	101	Gears	208
LP2515-LP3575	104	Brakes	222
LSP0818-LSP4275	106	ACCESSORIES	227
L20	108	Threaded Screws	228
L20-A	109	Threaded Nuts	230
LS20	110	Switch-Mode Power Supply	232
L28	111	Cable Set	234
L28-A	112	Electronic Components	240
		Connectors	241
		Charging Capacitor	242
		Damper	244
		Shaft Couplings	248

Lined area for notes with horizontal dashed lines.

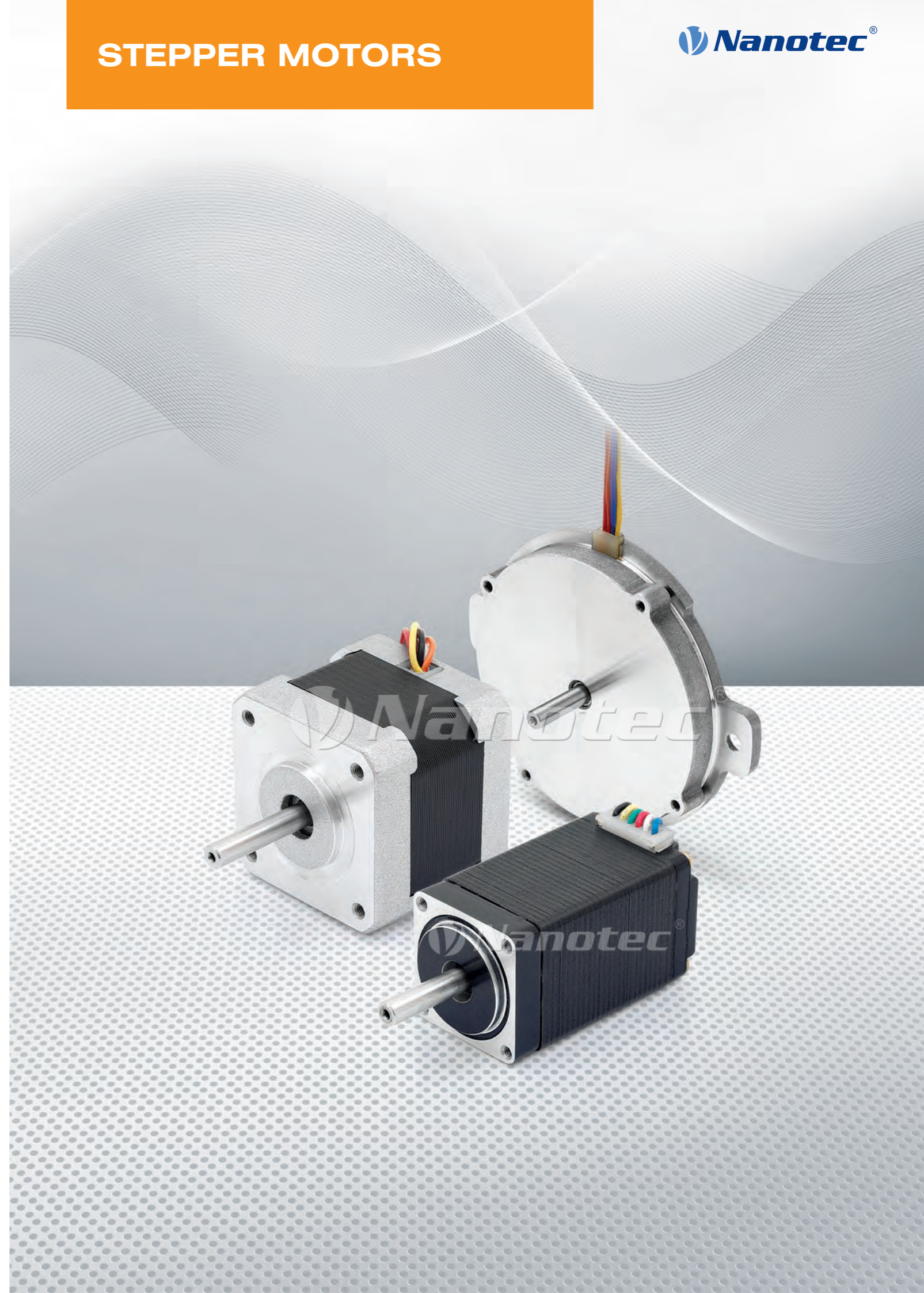

APPLICATION BENEFITS

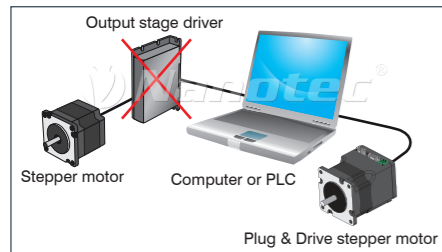

a) PC+PLC-capable (directly controllable via PC, PLC and microprocessor)
 Plug & Drive motors have the highest productivity increase due to the use of PCs even at the lowest, decentralized machine level. Not only do these motors drastically reduce the development, wiring and installation effort for a complete drive unit and increase EMC compatibility and machine availability, but they also greatly simplify setup, installation and servicing.

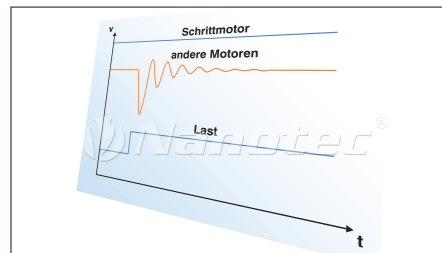

b) Turning speed stability
 "No drop in speed when load changes" - the stepper motor meets this requirement like no other motor, without additional effort. Especially when using controls for precise speed, synchronicity or ratios (such as for precise metering pumps), the stepper motor can achieve higher or finer resolutions thanks to digital processing. The improved control, process and surface quality are further advantages.

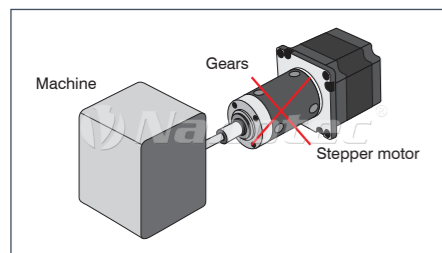

c) Direct drive
 Stepper motors have their maximum torque in the lower speed range and the Nanotec micro stepper drivers still achieve concentricity properties up to approx. 2 rpm. Other motors often need gears in order to fulfill the speed and force requirements. Direct drives reduce system costs while increasing operating safety and service life. Gears are certainly indispensable for adjusting performance and power if space is limited or when the external inertia torque is high.

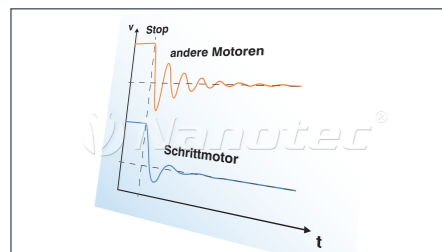

d) Positioning accuracy
 As a result of the small step angle, stepper motors also have, in addition to the lowest over run, the smallest transient response. Even without external path or angle sensors, stepper motors fulfill outstanding speed and positioning tasks. The precision or resolution can even be increased further without additional effort using Nanotec motor controllers thanks to microstep switching. All Nanotec stepper motors are also available with encoders for detecting blockages and closed-loop applications.

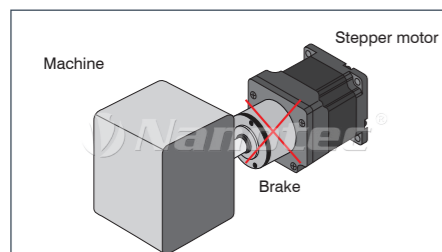

e) High stiffness without brake
 Stepper motors have the highest holding torque when idle and thus offer a high degree of system rigidity. Therefore an external brake can be omitted unless a safety brake is necessary for the Z-axis.

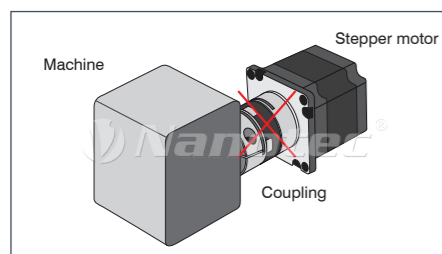

f) Avoiding damage to machines and injuries
 The disadvantage of "falling out of step" when a motor is blocked, an issue that is sometimes brought up in connection with stepper motors, can actually be of an advantage in some cases in view of increasingly stringent safety requirements. Slip and overload couplings are not normally required in statutory safety requirements in conjunction with stepper motors.

CONTROLLERS AND SWITCHING FEATURES

Almost all stepper motors can be provided with 4, 6 or 8 connection lines/leads. 4 leads are suited solely for bipolar operation, 6 leads for unipolar and limited bipolar operation and 8 leads for unipolar and bipolar operation. Even though unipolar operation is extremely simple using just 4 switches, it is rarely used today due to the availability of highly integrated constant current bipolar driver ICs with an approximately 30 % higher torque. This is also true for constant voltage operation where the power losses are high.

UNIPOLAR CONNECTION

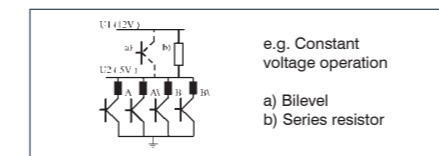

Unipolar switching sequences

Mode	1/1	1/2	A	A\	B	B\
1	1	1	+	0	0	+
2	2	3	+	0	+	0
3	3	4	0	0	+	0
4	4	5	0	+	+	0
5	5	6	0	+	0	0
6	6	7	0	+	0	+
7	7	8	0	0	0	+
8	8	1	+	0	0	+

BIPOLAR SWITCHING SEQUENCES

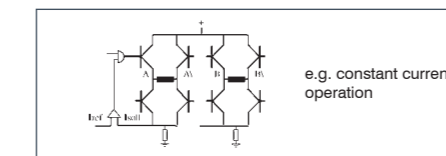

Bipolar switching sequences

Mode	1/1	1/2	A	B
1	1	1	+	+
2	2	2	+	0
3	3	3	+	-
4	4	4	0	-
5	5	5	-	0
6	6	6	-	+
7	7	7	0	+
8	8	8	+	+

STEPPER MOTOR ANIMATION

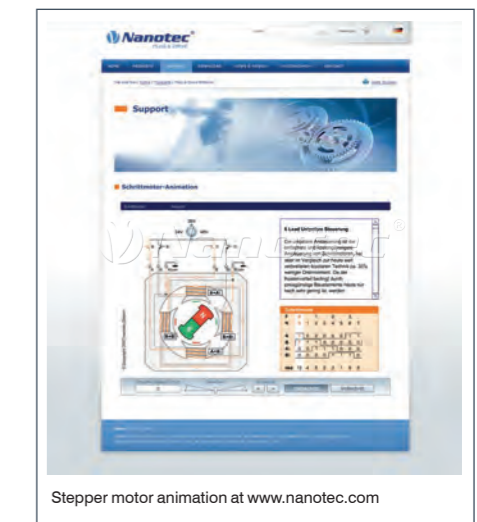

Connection arrangement of stepper motors

Stepper motors offered by Nanotec can be operated using various connection arrangements that each lend the motor different characteristics. The 4-lead design is already connected internally; there is only one connection options. Motors with 6 leads can be operated with one winding half or in series, those with 8 wires can be operated in all of the listed connection arrangements. Only bipolar activation, which is used almost exclusively today, is taken into consideration here.

- One half winding:** Only half of the motor's windings are used in this case. Therefore, the holding torque that can be achieved is less than in the other circuits. This circuit only provides benefits at the high speed range of 6-lead motors, which can be seen clearly in the respective motor curves.
- Parallel:** The highest motor output is achieved in this circuit. Due to the low inductance, the motor continues to keep the torque constant even at high speeds, however, a high phase current is also required.
- Series:** This circuit is well-suited for the low speed range where high torque is achieved with low current. Due to the high inductance, the torque quickly drops off at high speeds, however.

The values specified in the data sheet always refer to one half winding. The rule for converting to series or parallel circuits for individual parameters is shown in the following table. This function can also be carried out online on the overview page for the individual stepper motor series (under the controller type).

Value	1 winding half as in data sheet	Series	Parallel
Resistance	R	2 * R	R / 2
Inductance	L	4 * L	L
Phase current	I	I / √2	I * √2
Holding torque	M	M * √2	M * √2

The holding torque is achieved at the respective nominal current. If the current deviates, then the value can be calculated accordingly from the proportionality between phase current and holding torque. Thus, half the current results in half of the holding torque (for the same circuit).

CAUTION

This context only applies to holding torque and to the low speed range (where torque does not yet drop off), but not to the entire motor curve. At high speeds, the configured current can no longer achieve its maximum value since the switching processes at the winding are then too fast. This (real) current reduction leads to a decrease in the motor curve as speed increases.

It is also possible to operate the motor briefly with higher current. In that case, however, care must be taken not to exceed a housing temperature of 80 °. Saturation occurs at 1.5-2 times the value of the nominal current in the process depending on the motor, after which the moment no longer increases.



OPTIONS



DESCRIPTION

Permanent magnet stepper motors offer an economical alternative for use in simple device applications with large step angles.

Features

- Cost-effective
- High-quality plain bearings on both sides
- Large torque relative to size

The SPG motors integrate a gear with a reduction of 50 or 102.

VERSIONS

Type	Step Resolution ° (full step)	Current per Winding A/Winding	Voltage per Winding V/Winding	Holding Torque Ncm	Resistance per Winding Ohm	Inductance per Winding mH	Rotor Inertia gcm ²	Weight kg	Size mm
SP1018M0204-A	18	0.22	3.3	0.16	15	3	0.01	0.004	10
SP1518M0104-A	18	0.065	12.4	0.2	190	50	1	0.012	15
SP1518M0204-A	18	0.24	12	0.2	50	9.2	1	0.012	15
SPG1518M0504-50	0.36	0.5	5	13.5	10	2.3	1	0.012	15
SPG1518M0504-102	0.176	0.5	5	20	10	2.3	1	0.012	15
SP2018M0506-A	18	0.35	5	0.71	10	1.85	1	0.026	20
SP2515M0406-A	15	0.3	5	1.41	11.5	2.3	1	0.036	25
SP2575M0206-A	7.5	0.17	12	1.56	50	12	1	0.036	25
SP2575M0506-A	7.5	0.35	5	1.98	10	2	1	0.036	25
SP2575M0704-A	7.5	0.76	3.8	1	5	3	1	0.036	25
SP3575S0506-A	7.5	0.35	5	5.66	10	3.8	5	0.09	35
SP3575M0906-A	7.5	0.61	5	7.78	5.8	3.2	7.5	0.09	35
SP4275S0606-A	7.5	0.42	5	7.07	8.6	4.5	9.6	0.011	42
SP4275M0806-A	7.5	0.57	5	8.49	6.2	5.5	9.6	0.13	42
SP5575M0106-A	7.5	0.08	12	21.21	100	107	12.5	0.27	57
SP5575M0604-A	7.5	0.625	5.6	12	9	19.9	12.5	0.27	57

The current and holding torque values refer to bipolar serial wiring. The resistance and inductance values refer to unipolar wiring.

ORDER IDENTIFIER

SP(G) 3575 S 05056 -
A = single shaft

ACCESSORIES

ZK-JST-VL-4 Cable for XHP4 Plug
ZK-JST-VL-6 Cable for XHP6 Plug

DIMENSIONS (IN MM)

SP1018M

Front view and mounting

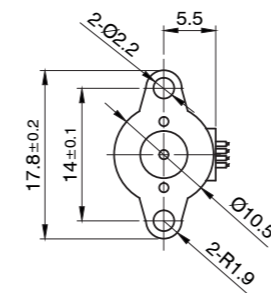

Side view

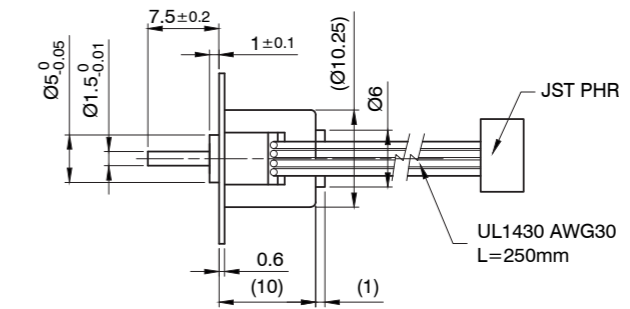

Rear view

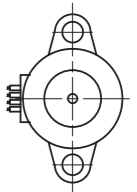

SP1518M

Front view and mounting

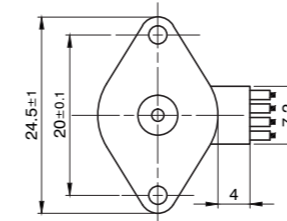

Side view

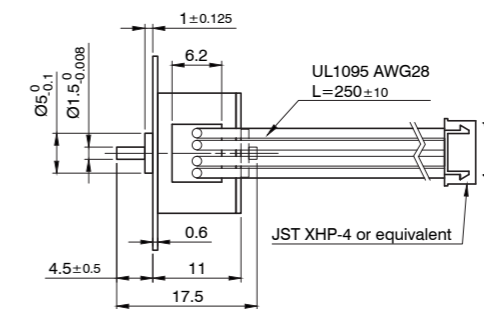

Rear view

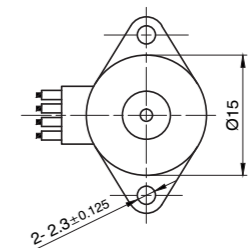

DIMENSIONS (IN MM)

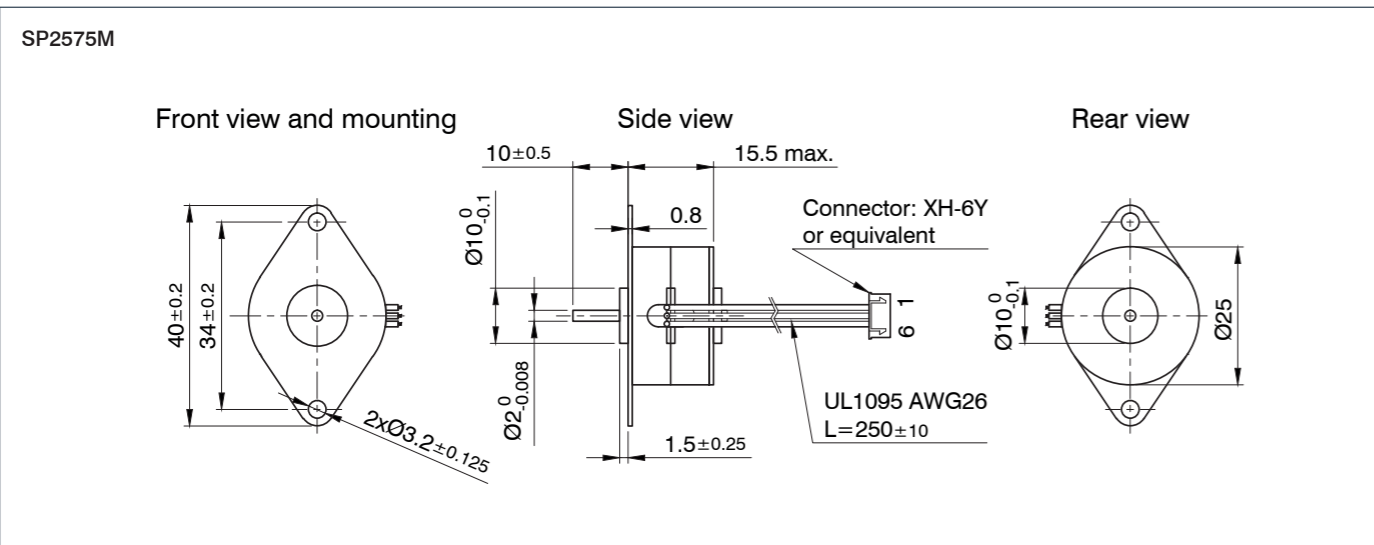
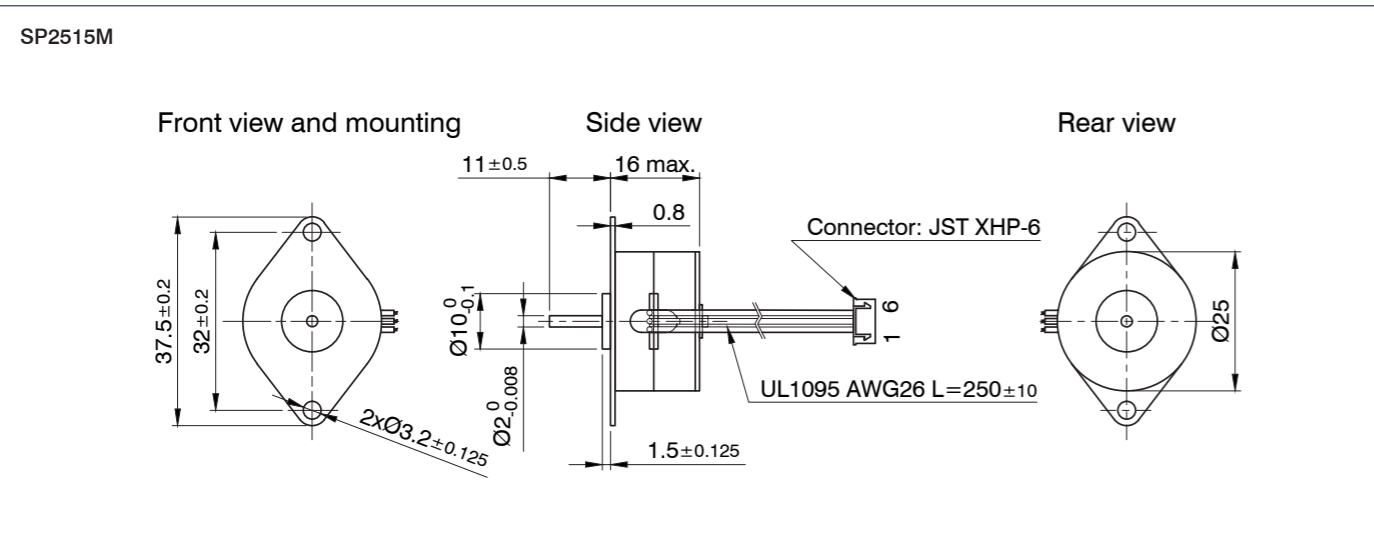
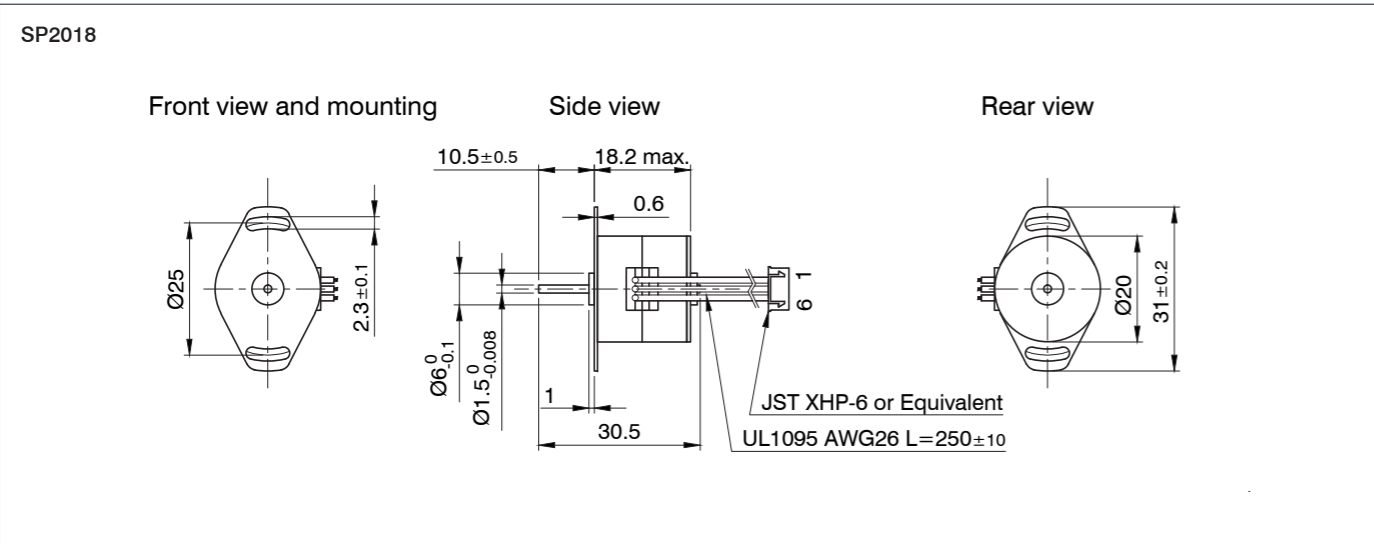

DIMENSIONS (IN MM)

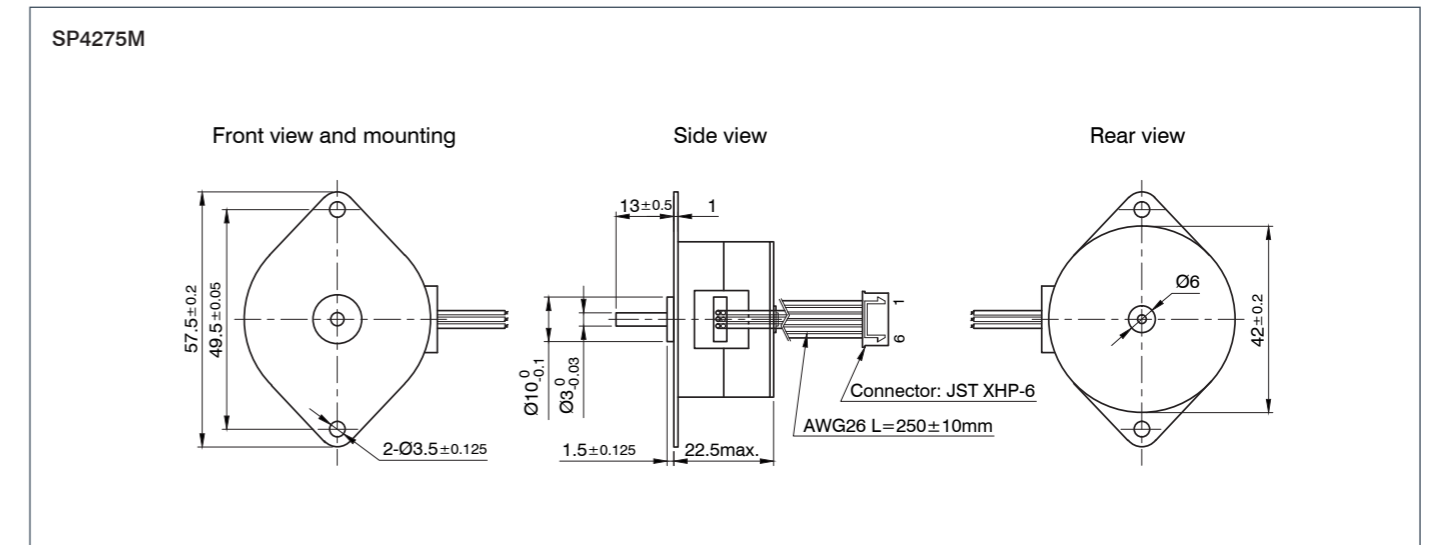
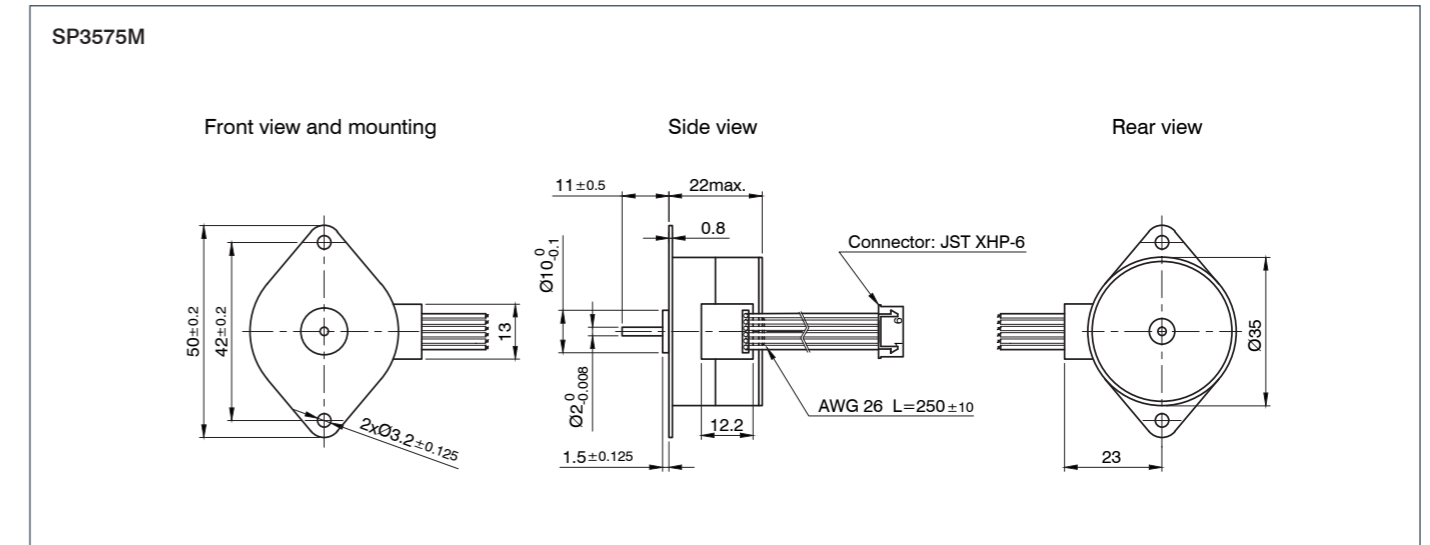
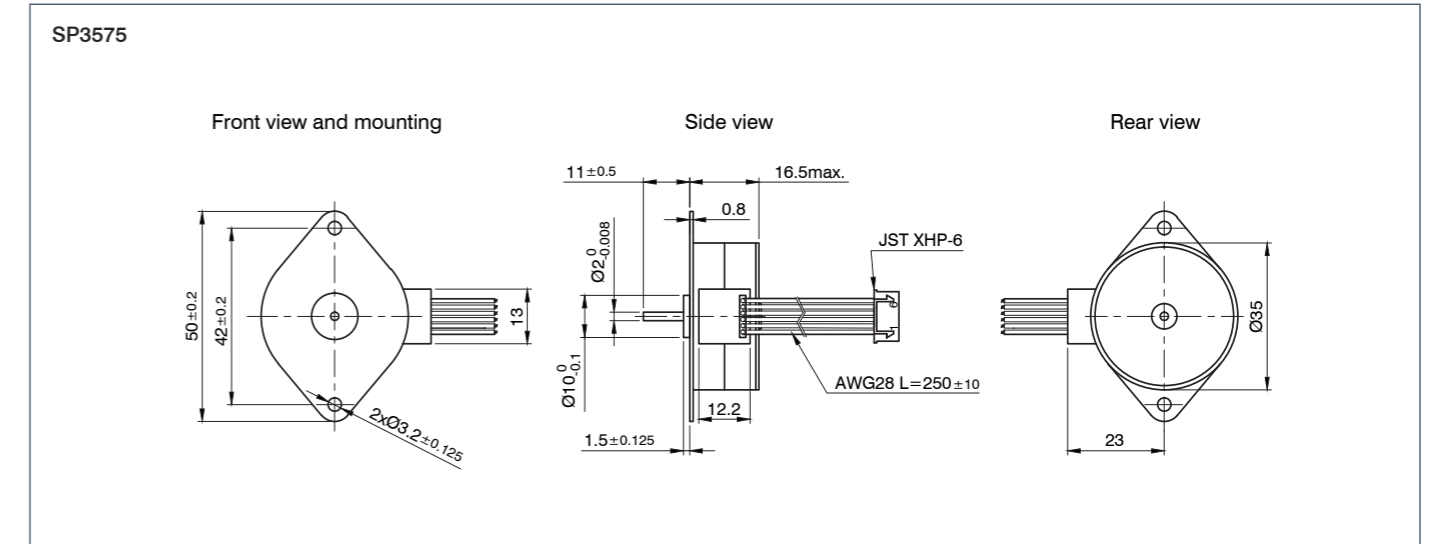

DIMENSIONS (IN MM)

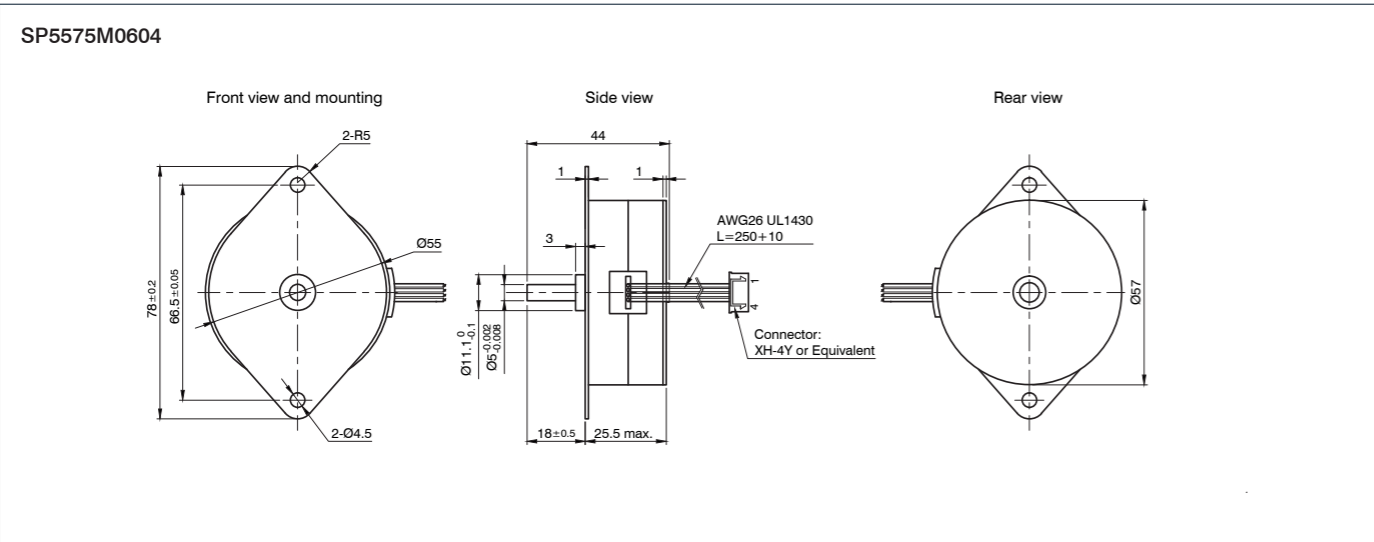
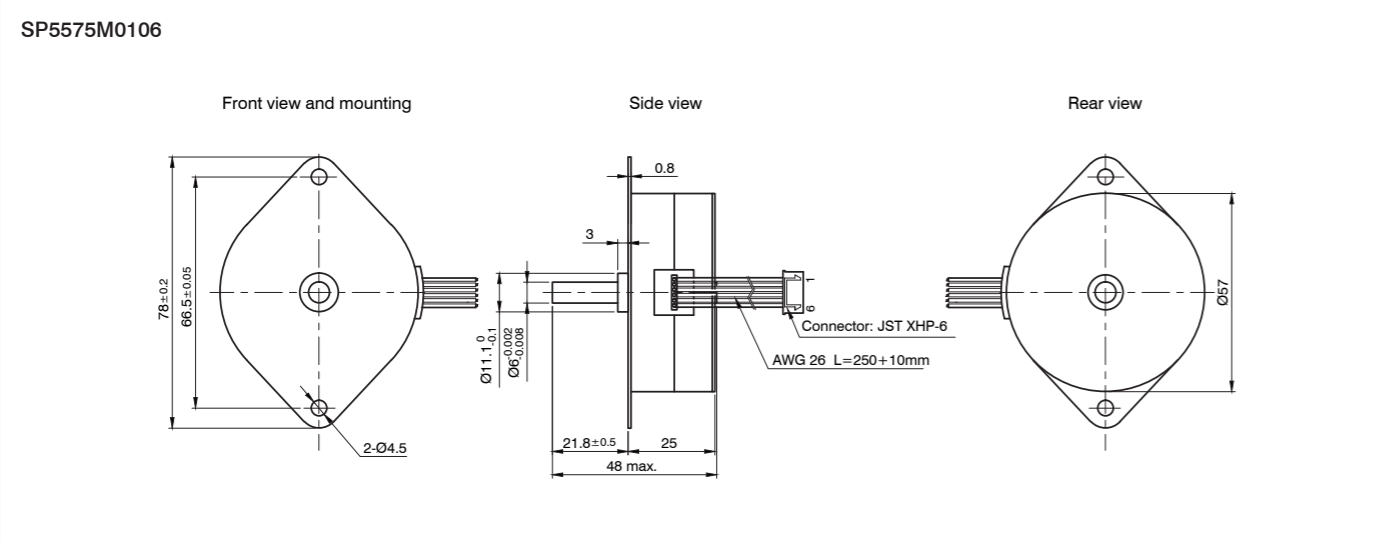
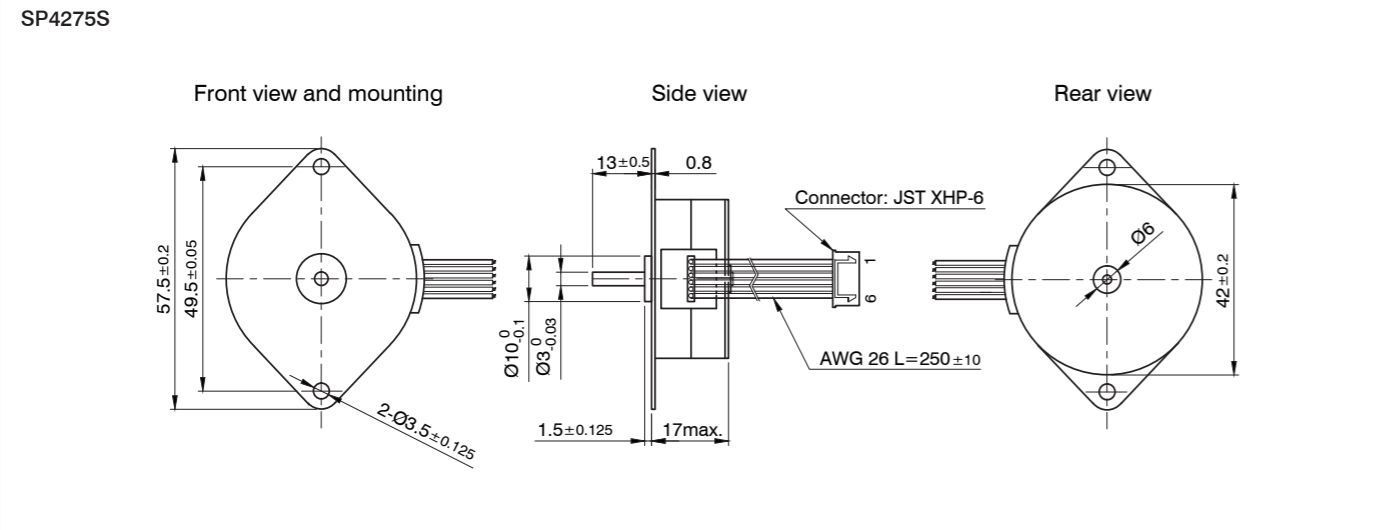

DIMENSIONS (IN MM)

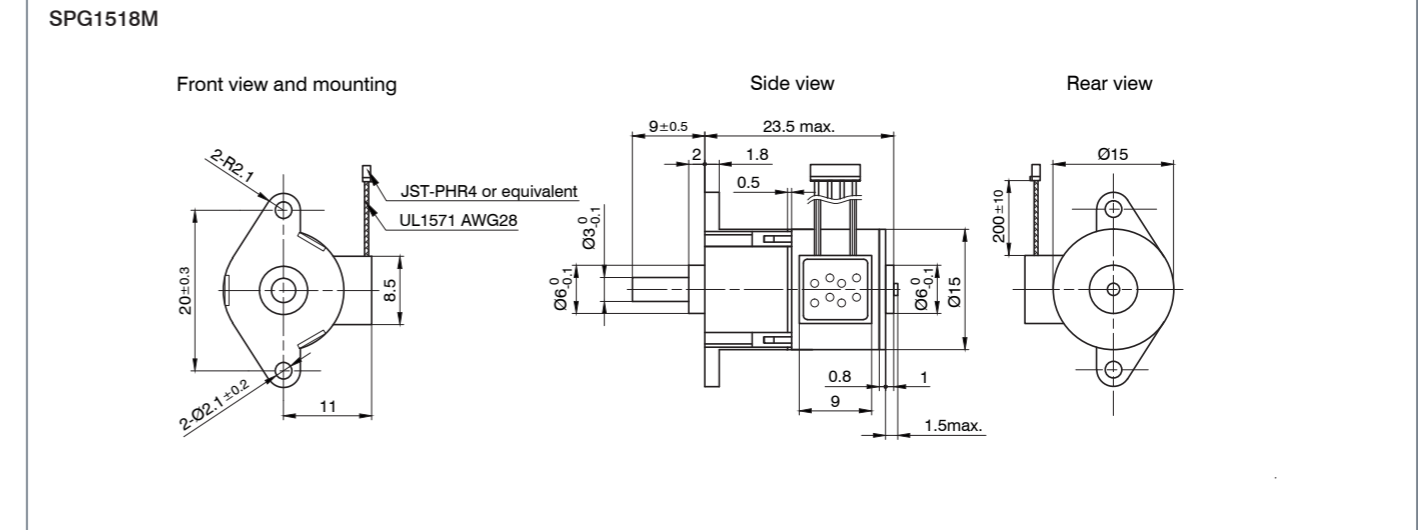

TORQUE CURVES

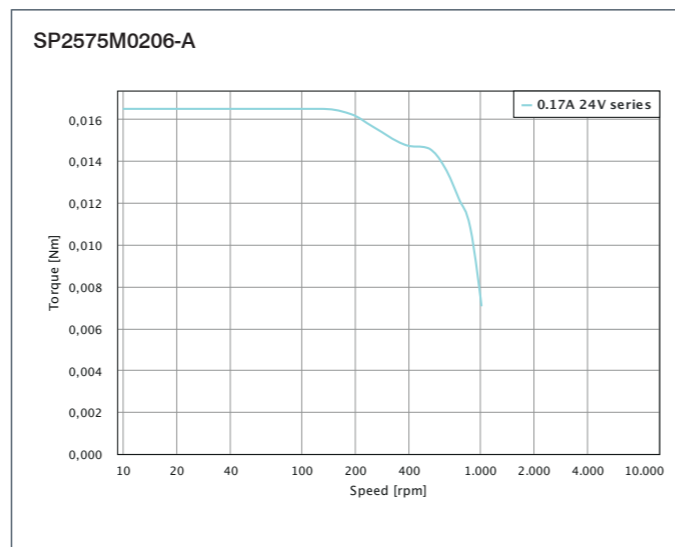
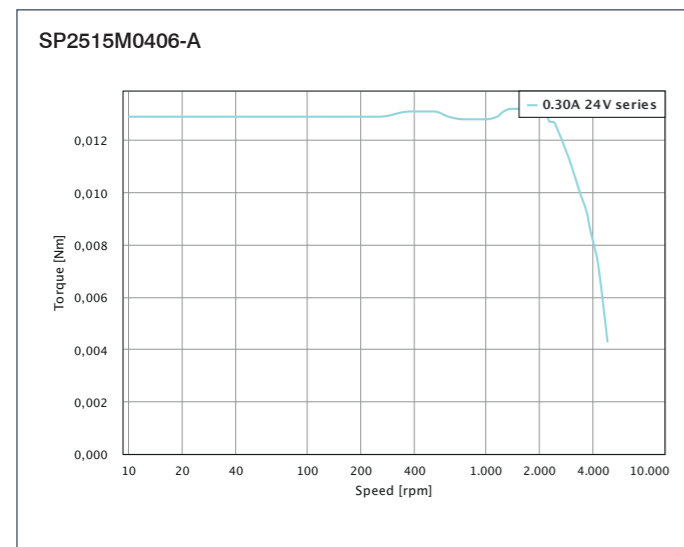
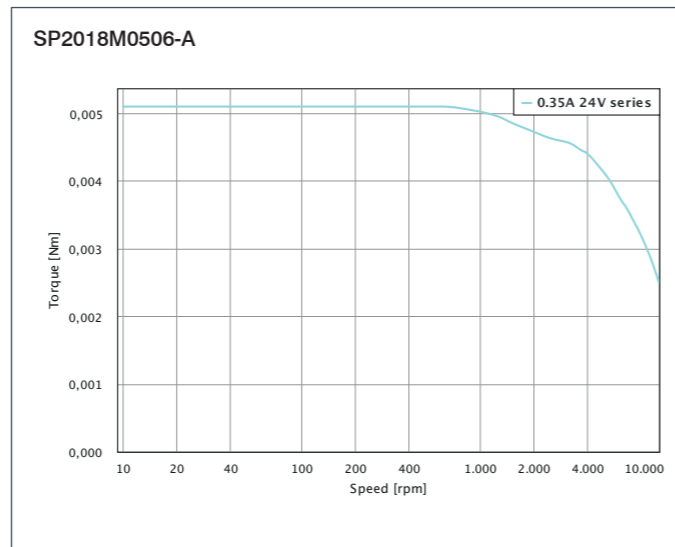
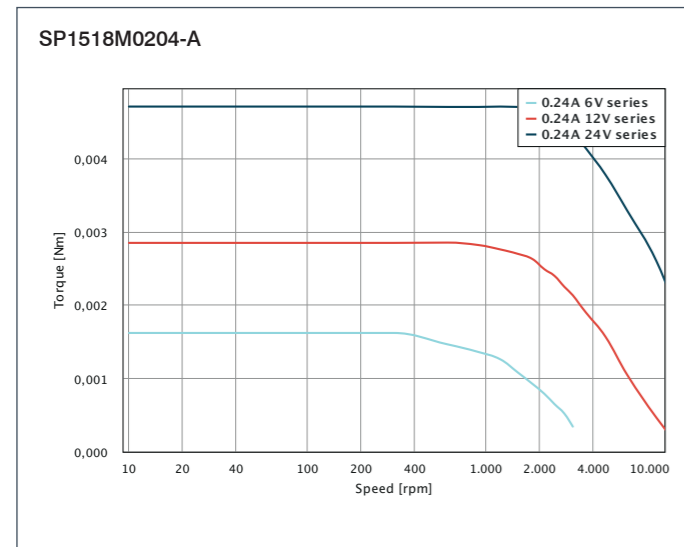
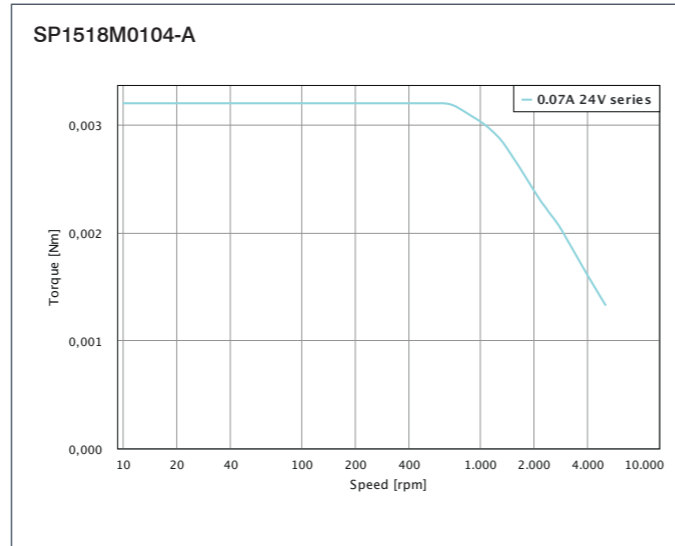
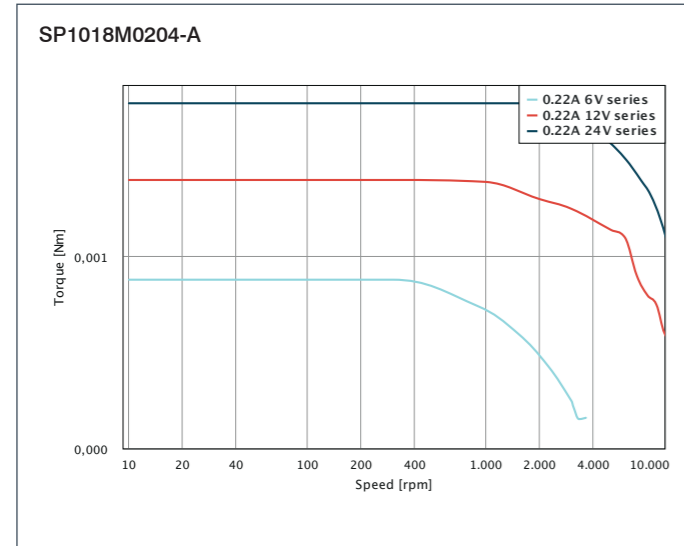

TORQUE CURVES

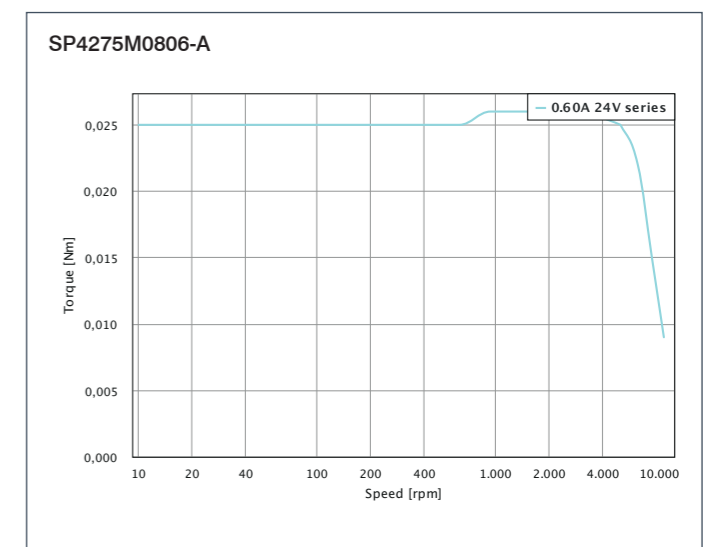
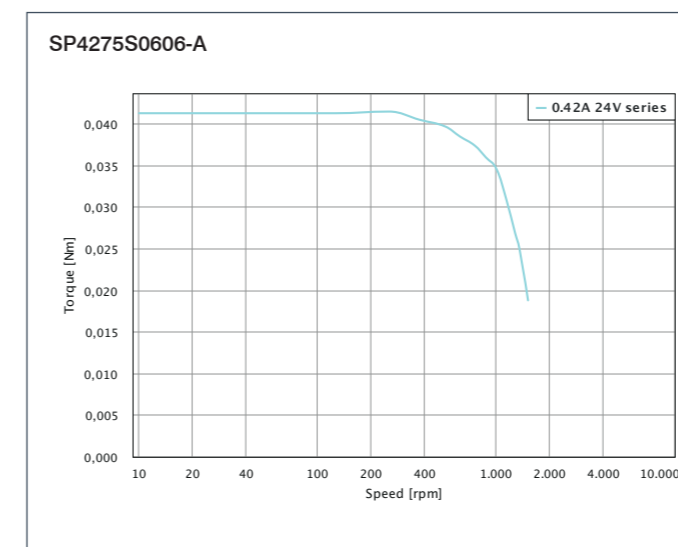
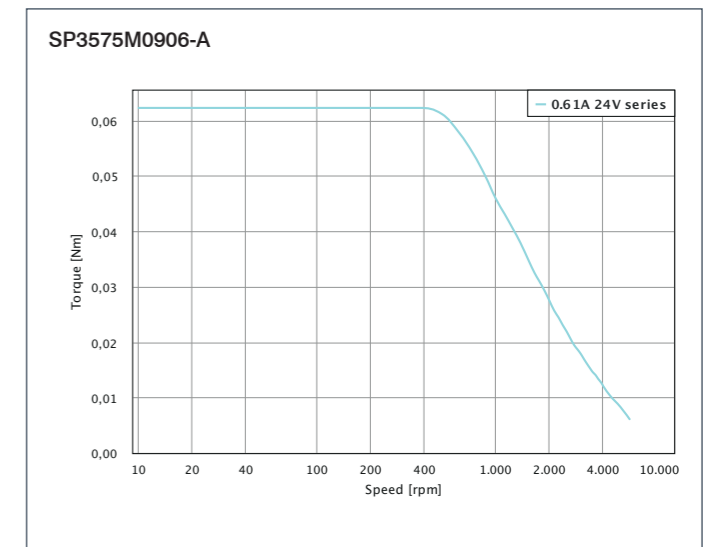
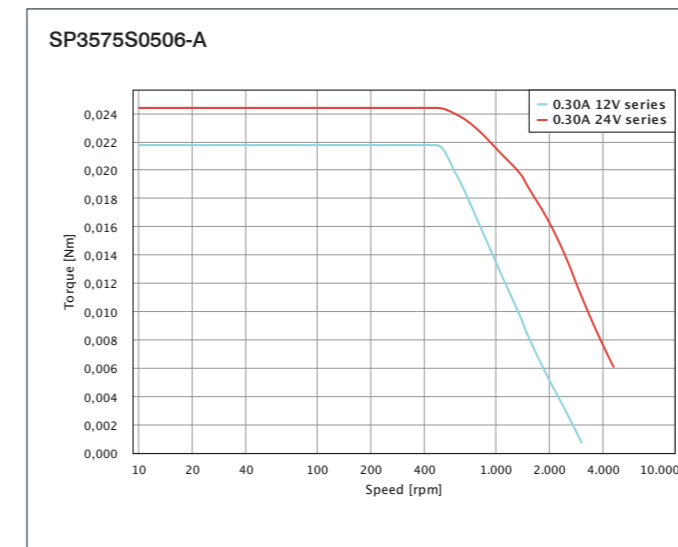
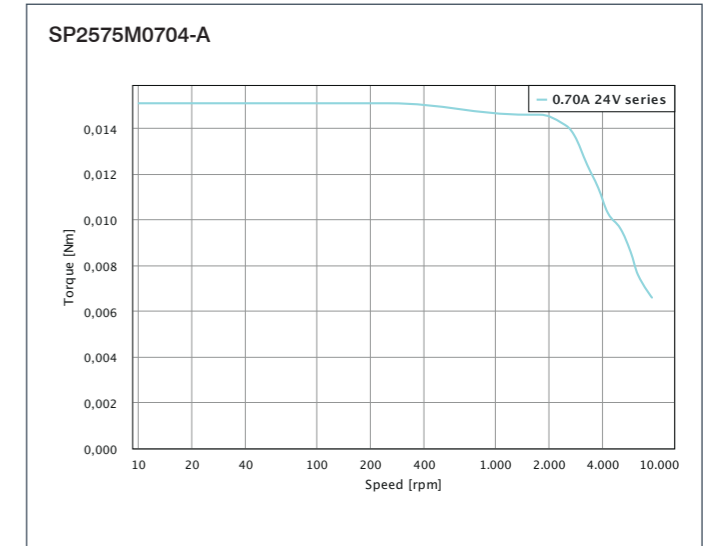
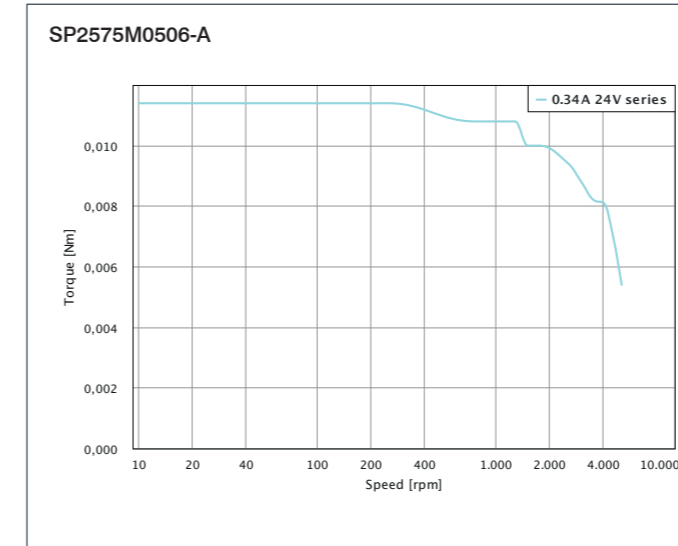

TORQUE CURVES

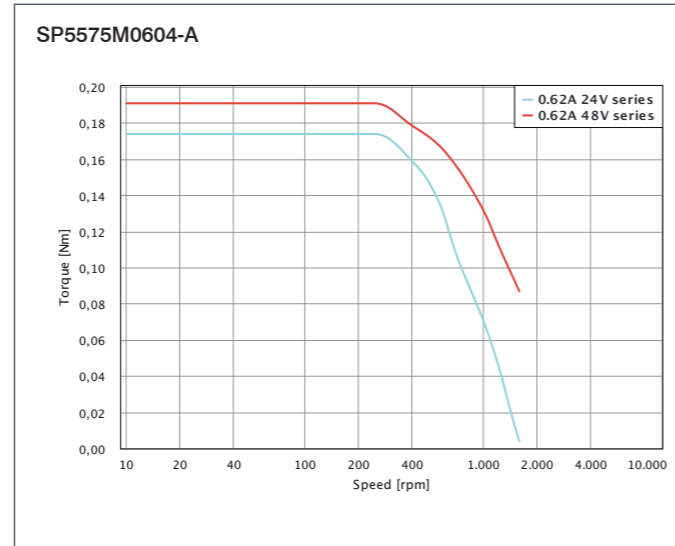
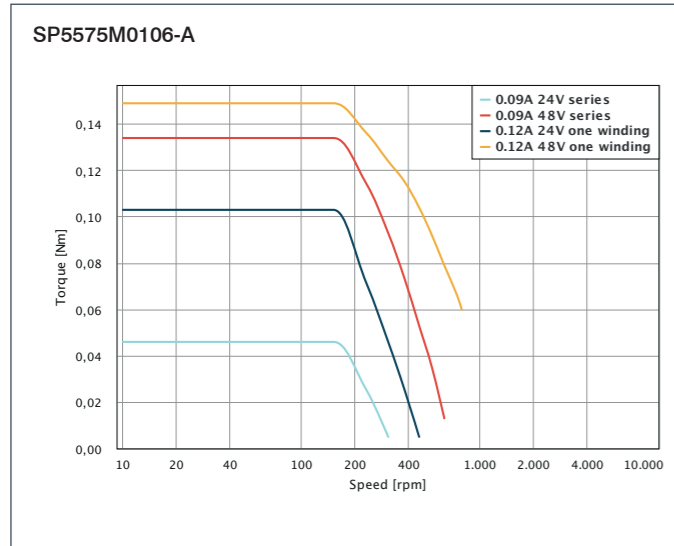



OPTIONS



VERSIONS

Type	Current per Winding A/Winding	Holding Torque Ncm	Resistance per Winding Ohm	Inductance per Winding mH	Rotor Inertia gcm ²	Weight kg	Length „A“ mm
ST2018S0604	0.6	1.8	6.5	1.7	2	0.06	33
ST2018M0804	0.8	3	5.4	1.5	3.6	0.08	42
ST2018L0804	0.8	3.6	6	2.2	4.3	0.09	48

ORDER IDENTIFIER

ST2018S0604-
A = single shaft
B = double shaft

ACCESSORIES

ZK-JST-VL-4 Cable for XHP4 Plug

DIMENSIONS (IN MM)

ST2018

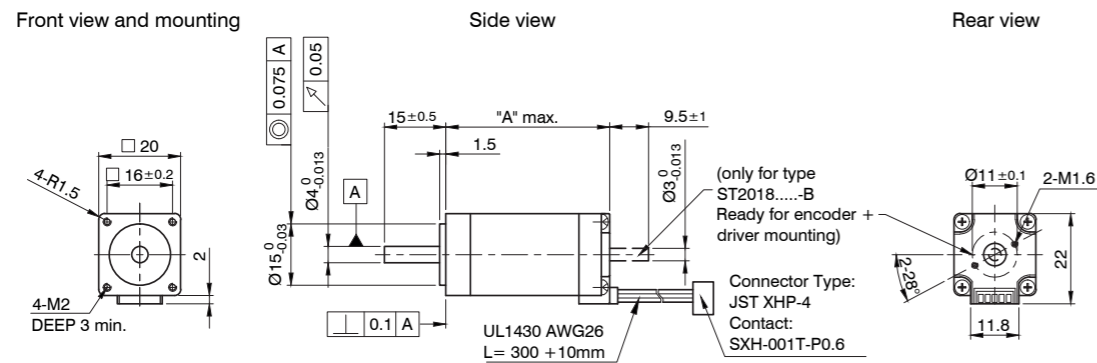

TORQUE CURVES

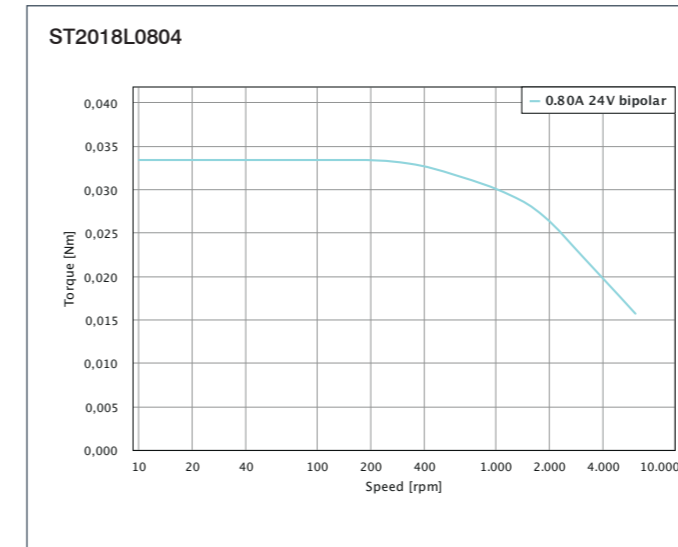
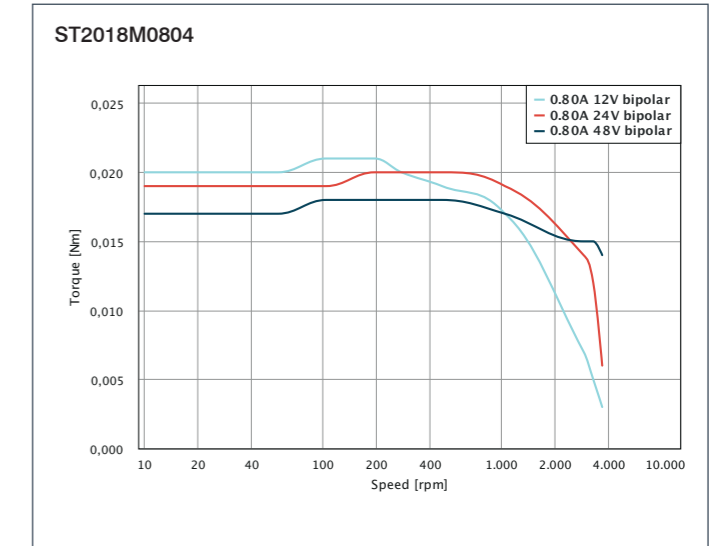
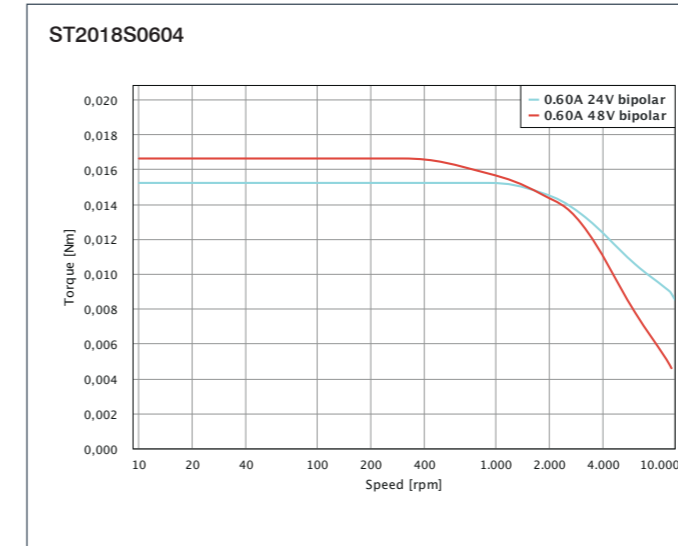



OPTIONS



VERSIONS

Type	Current per Winding A/Winding	Holding Torque Ncm	Resistance per Winding Ohm	Inductance per Winding mH	Rotor Inertia gcm ²	Weight kg	Length „A“ mm
ST2818S1006	0.67	6.08	2.8	1	9	0.11	32
ST2818M1006	0.67	10.61	3.4	1.2	12	0.176	45
ST2818L1006	0.67	12.73	4.6	1.4	18	0.25	51
ST2818L1404	1.4	11.7	2.3	1.8	18	0.25	51

The current and holding torque values refer to bipolar serial wiring. The resistance and inductance values refer to unipolar wiring.

ORDER IDENTIFIER

ST2818S1006-
A = single shaft
B = double shaft

ACCESSORIES

ZD-D28 Damper
ZK-JST-VL-4 Cable for XHP4 Plug
ZK-JST-VL-6 Cable for XHP6 Plug

DIMENSIONS (IN MM)

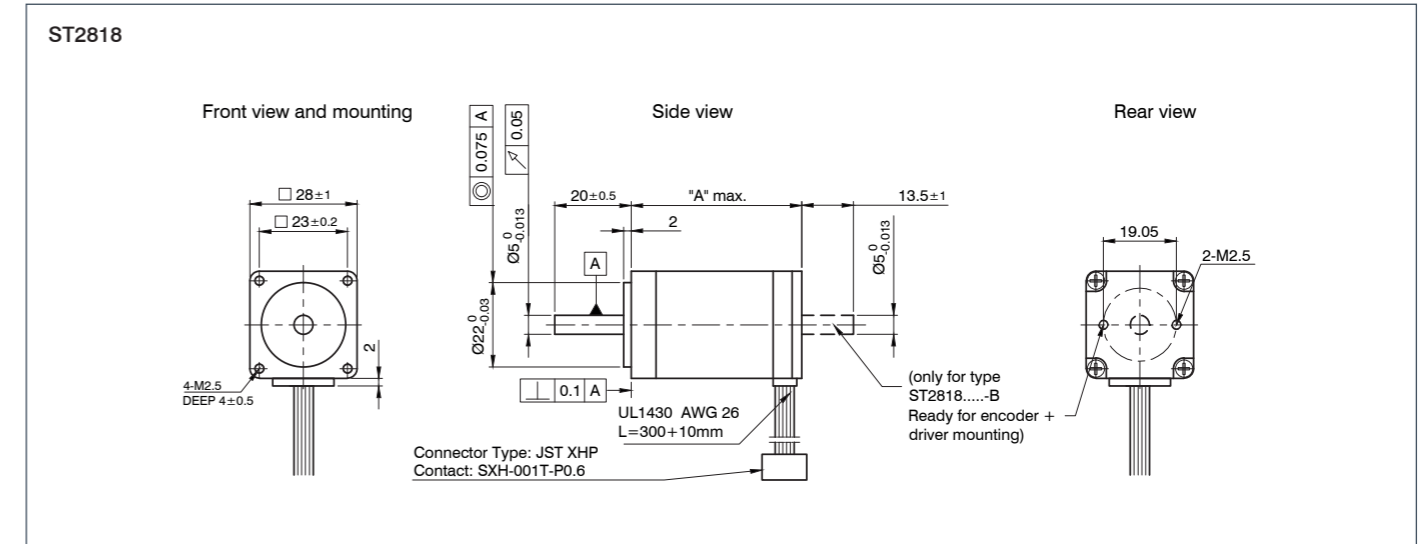

TORQUE CURVES

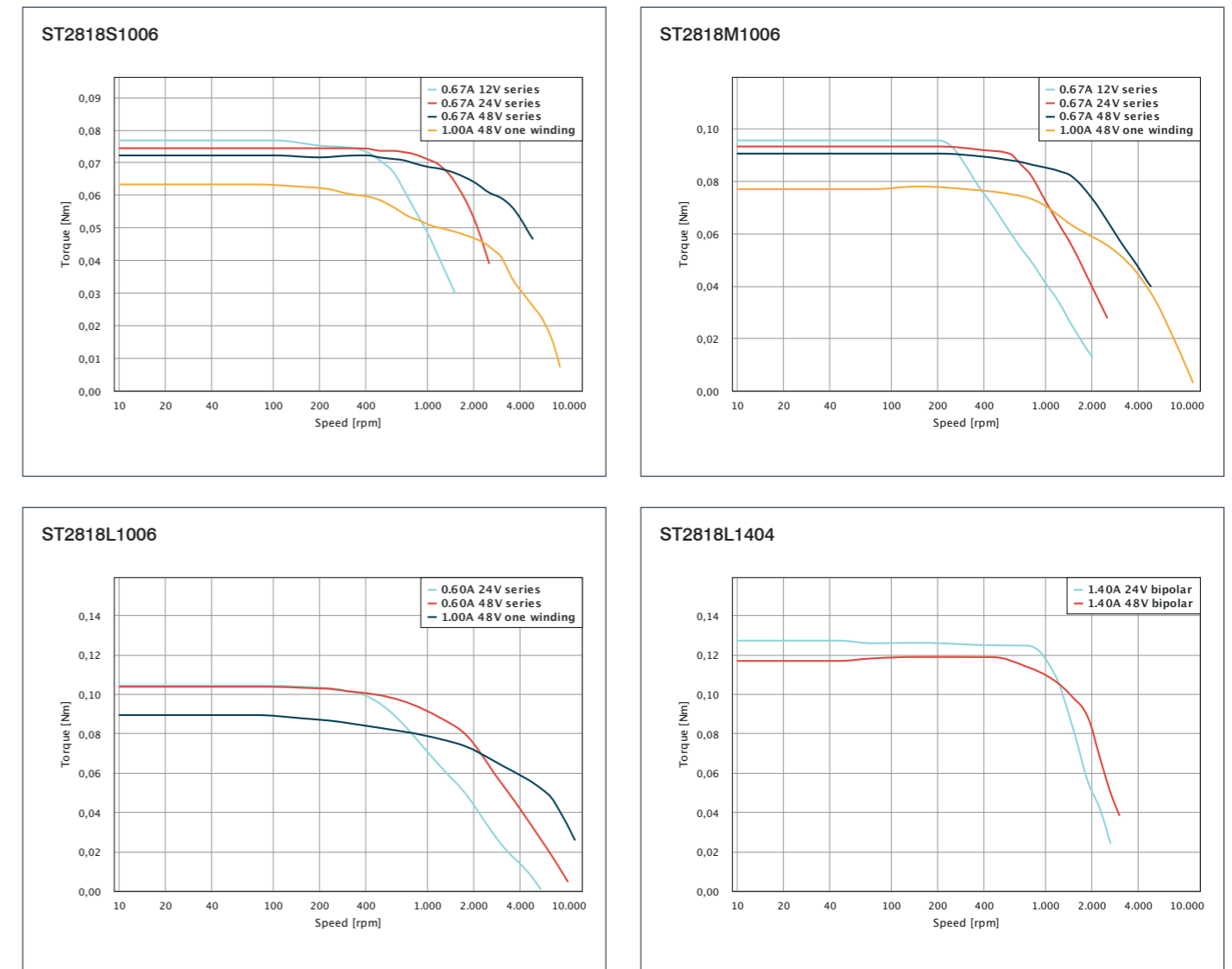



OPTIONS



VERSIONS

Type	Current per Winding A/Winding	Holding Torque Ncm	Resistance per Winding Ohm	Inductance per Winding mH	Rotor Inertia gcm ²	Weight kg	Length „A“ mm
STF2818X0504-A	0.5	0.98	3.7	0.88	1.7	0.028	9.4

ORDER IDENTIFIER



STF2818X0504-A

DIMENSIONS (IN MM)

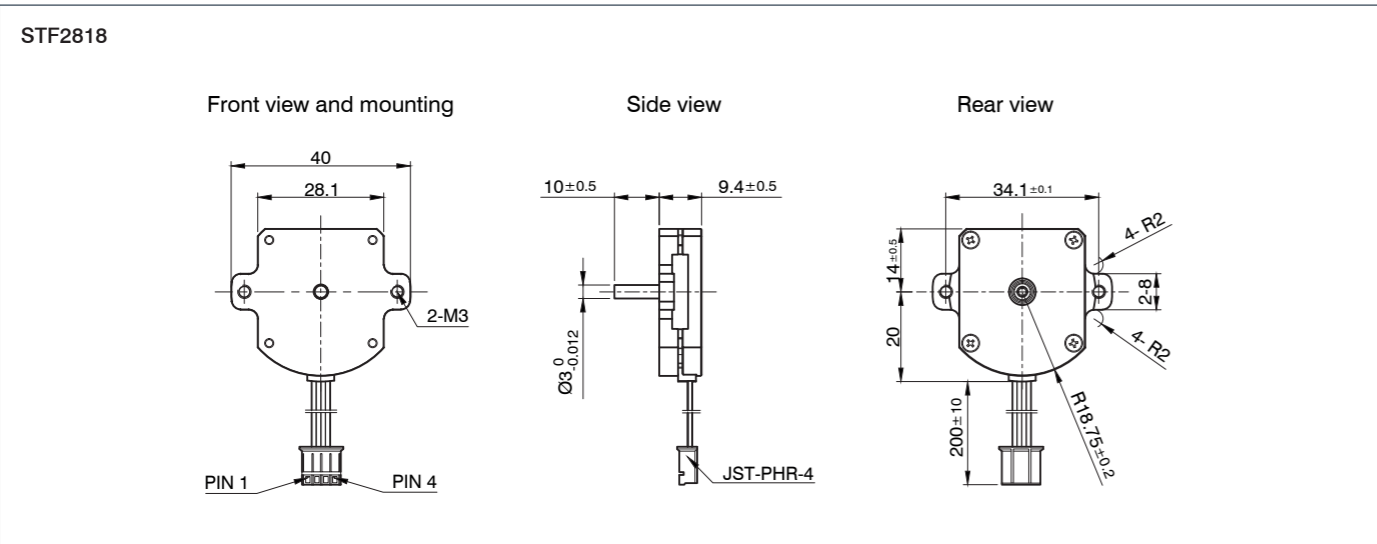

TORQUE CURVES

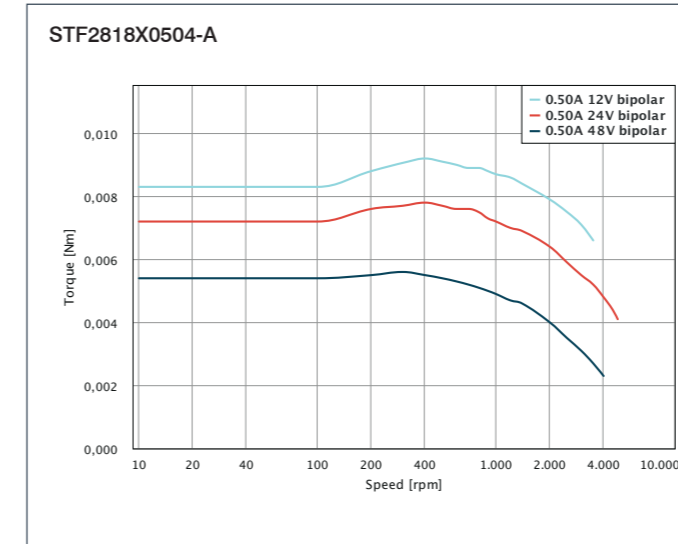



OPTIONS



VERSIONS

Type	Current per Winding A/Winding	Holding Torque Ncm	Resistance per Winding Ohm	Inductance per Winding mH	Rotor Inertia gcm ²	Weight kg	Length „A“ mm
ST3518S0804	0.8	5	4	2.3	10	0.15	26
ST3518M1004	1	14	2.7	4.3	14	0.18	36
ST3518L1204	1.2	23	3.4	4.5	43	0.3	52

ORDER IDENTIFIER

ST3518S0804-
A = single shaft
B = double shaft

ACCESSORIES

ZD-D28 Damper
ZK-JST-VL-4 Cable for XHP4 Plug

DIMENSIONS (IN MM)

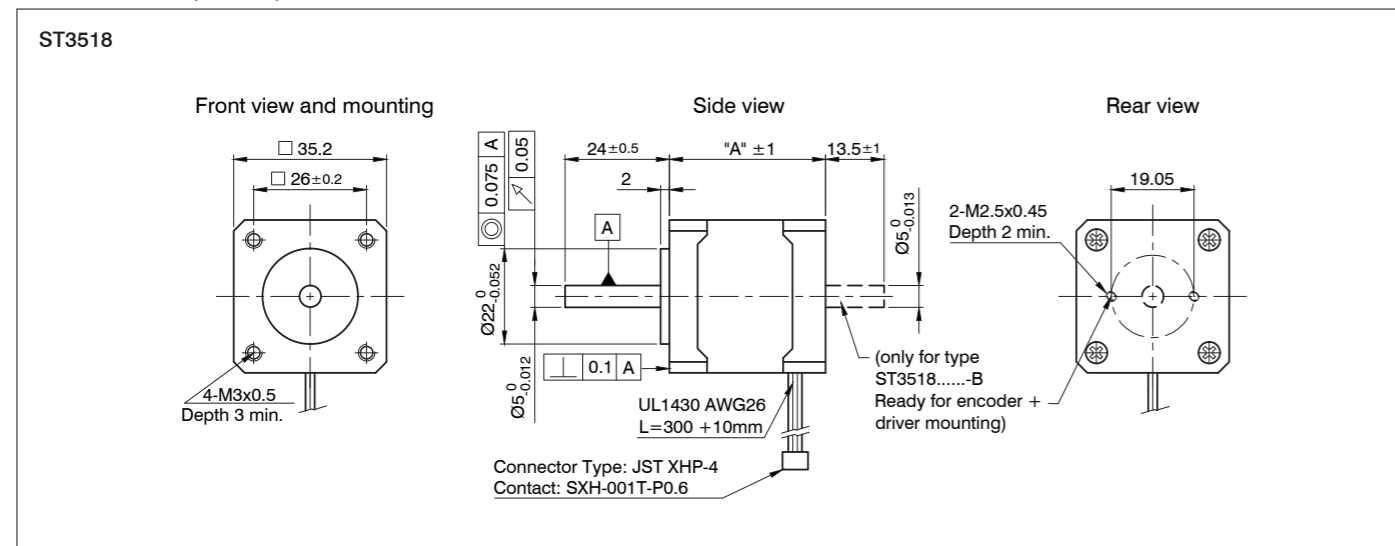

TORQUE CURVES

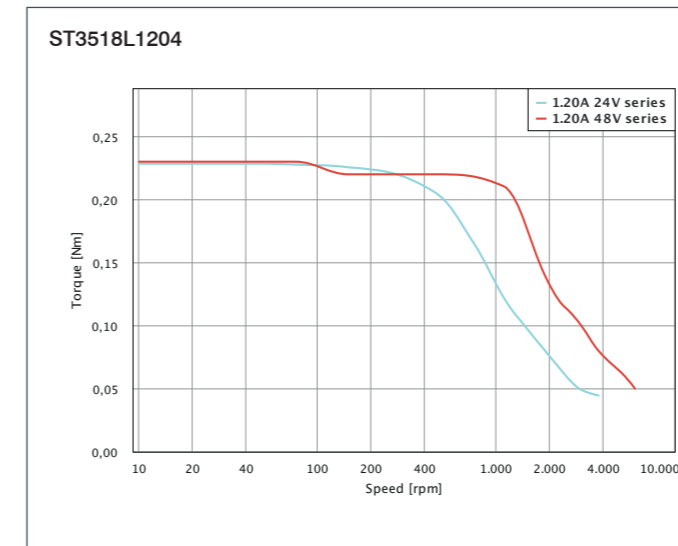
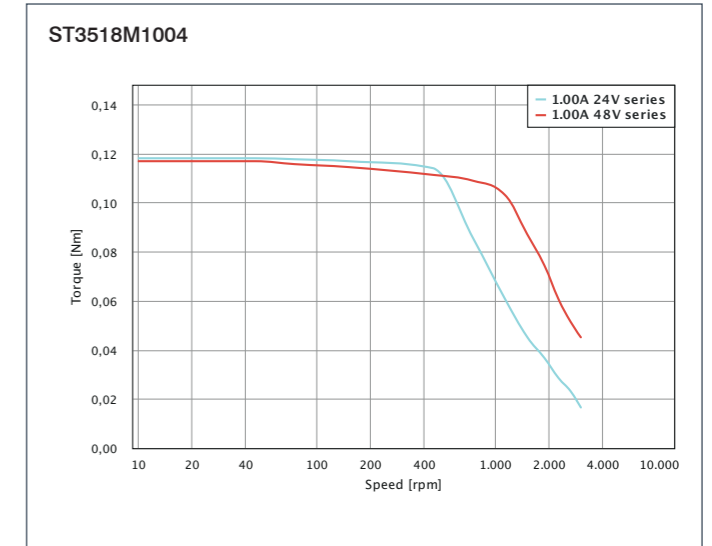
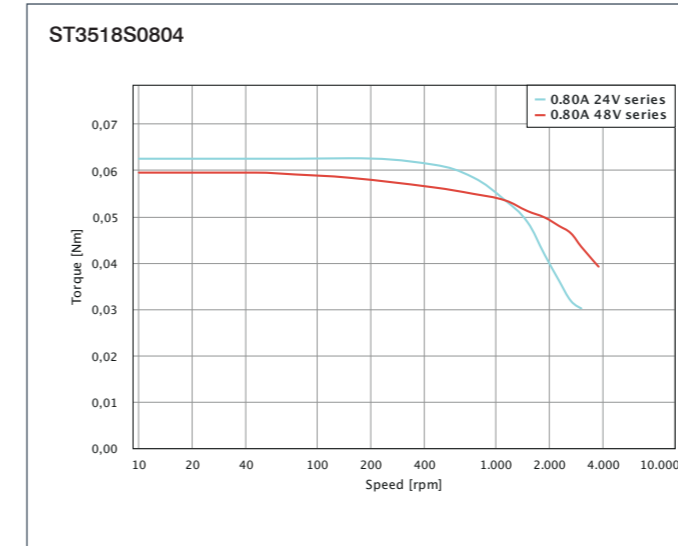



OPTIONS



VERSIONS

Type	Current per Winding A/Winding	Holding Torque Ncm	Resistance per Winding Ohm	Inductance per Winding mH	Rotor Inertia gcm ²	Weight kg	Length „A“ mm
ST4118X0404	0.4	17	24	36	20	0.15	26
ST4118X1404	1.4	9	2	1.6	20	0.15	26
ST4118S0206	0.16	21.21	75	53	38	0.2	31
ST4118S0406	0.25	22.63	30	21.7	38	0.2	31
ST4118S0706	0.49	22.63	7.6	6.8	38	0.2	31
ST4118S1006	0.67	21.21	3.9	2.8	38	0.2	31
ST4118S1404	1.4	20	2	3.6	38	0.2	31
ST4118M0406	0.28	39.6	30	25	57	0.24	38
ST4118M0706	0.49	39.6	9.5	8	57	0.24	38
ST4118M0906	0.64	39.6	5.7	5	57	0.24	38
ST4118M1206	0.85	39.6	3.1	2.9	57	0.24	38
ST4118M1404	1.4	24	1.2	1.7	57	0.24	38
ST4118M1804	1.8	28	1.1	1.85	57	0.24	38
ST4118L0804	0.8	50	9.3	17	83	0.34	49
ST4118L1206	0.85	49.5	3.3	3.4	82	0.34	49
ST4118L1804	1.8	50	1.75	3.3	83	0.34	49
ST4118L3004	3	50	0.63	1.03	82	0.34	49
ST4118D1804	1.8	80	3	7	102	0.5	60
ST4118D3004	3	80	1.1	2.7	102	0.5	60

The current and holding torque values refer to bipolar serial wiring. The resistance and inductance values refer to unipolar wiring.

ORDER IDENTIFIER

ST4118X1404-

A = single shaft
B = double shaft

ACCESSORIES

ZD-D40 Damper
ZD-DF40 Damper
ZK-JST-VL-4 Cable for XHP4 Plug
ZK-JST-VL-6 Cable for XHP6 Plug

DIMENSIONS (IN MM)

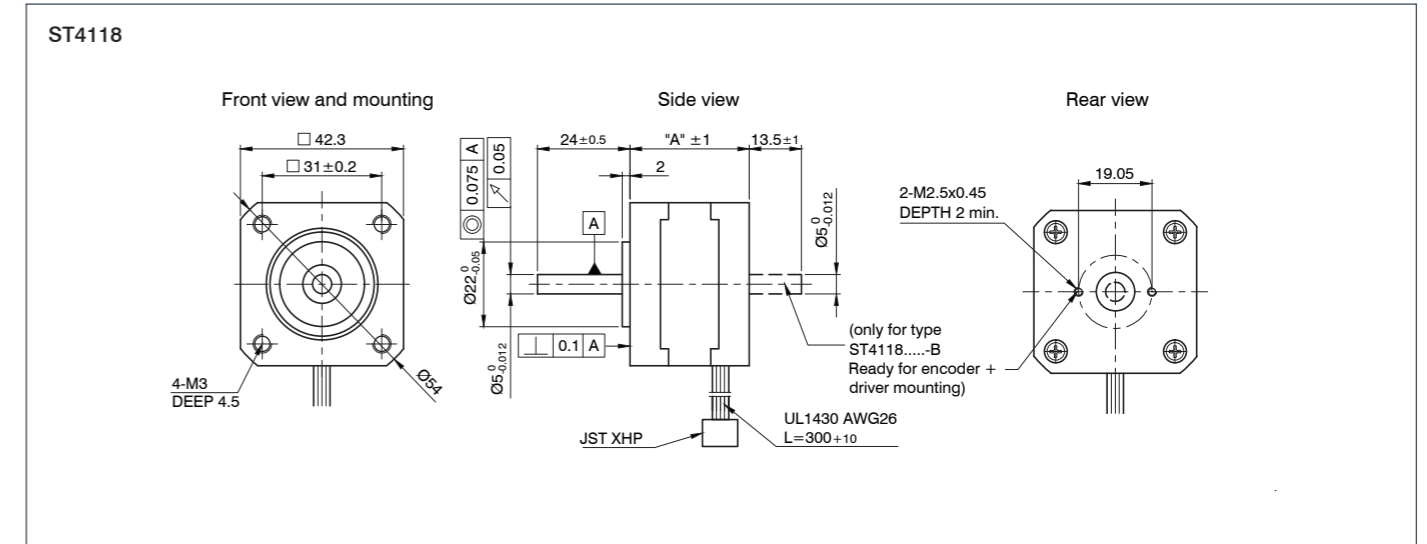

TORQUE CURVES

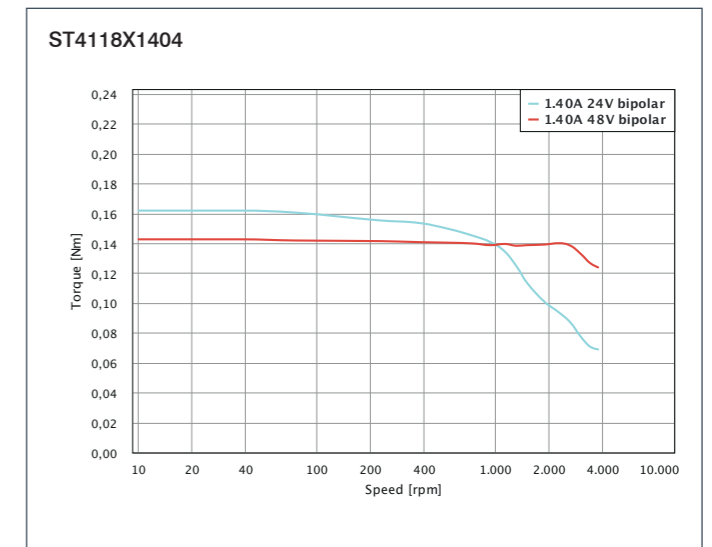
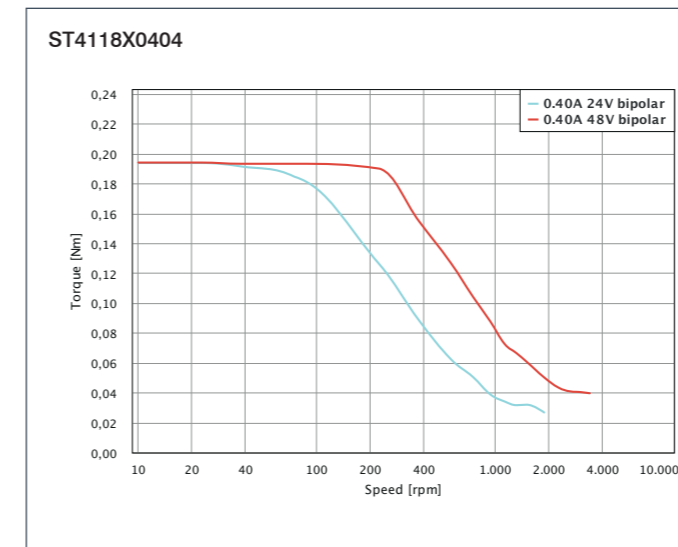

TORQUE CURVES

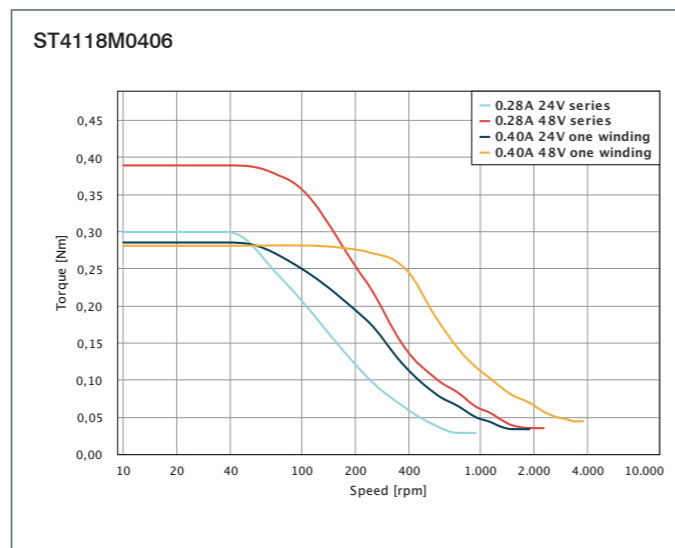
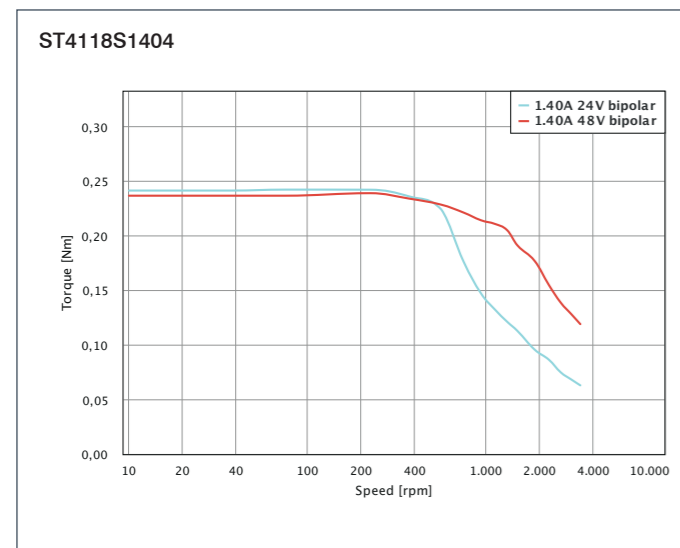
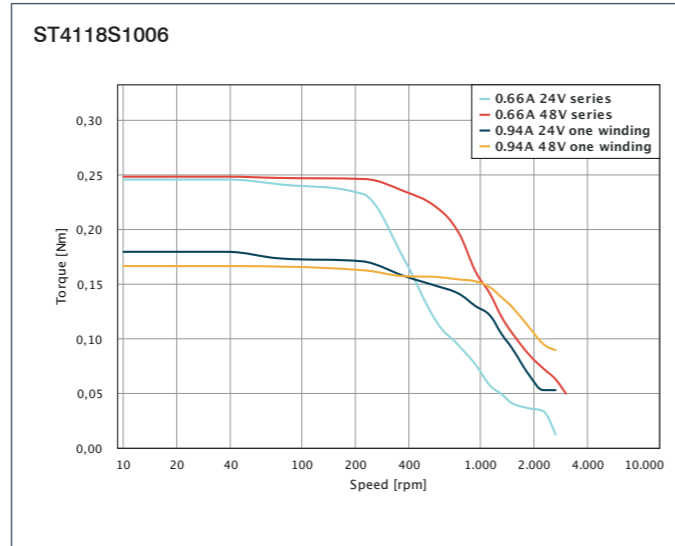
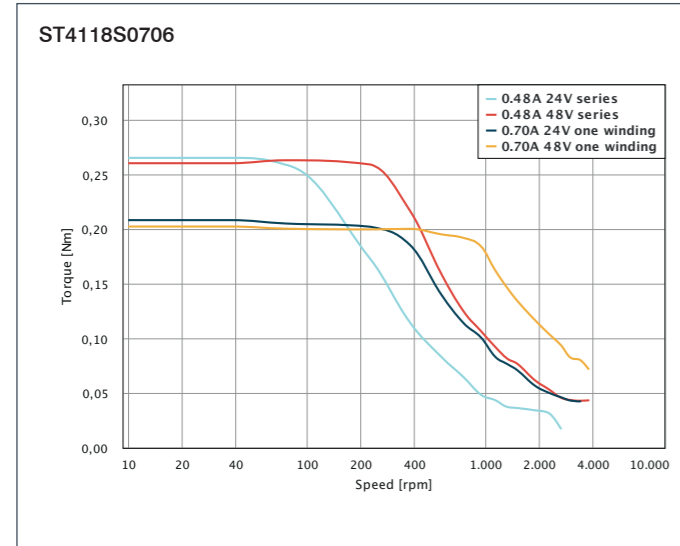
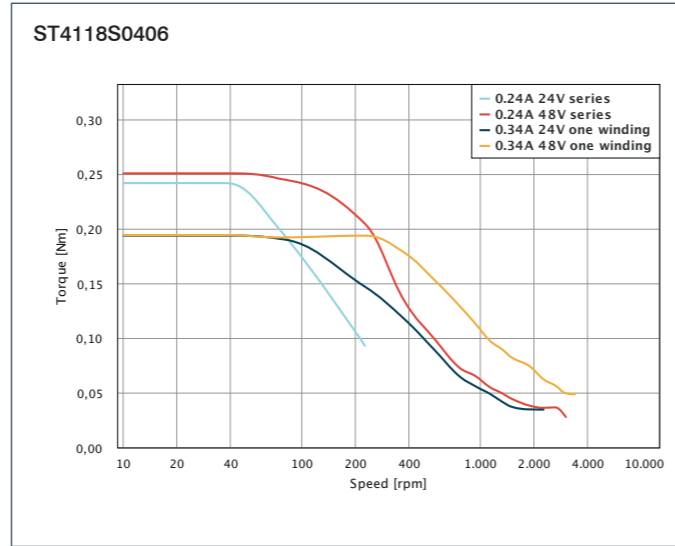
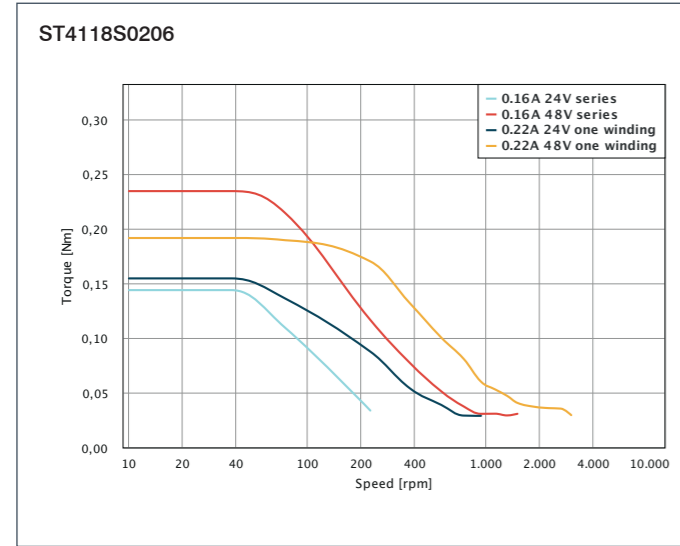

TORQUE CURVES

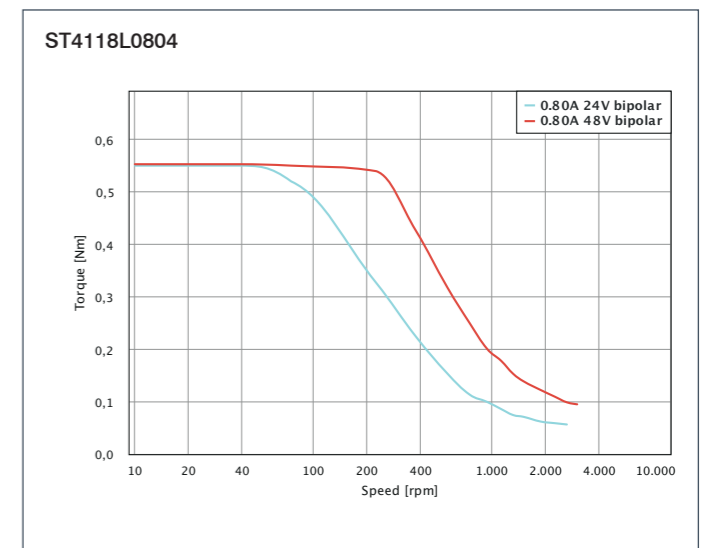
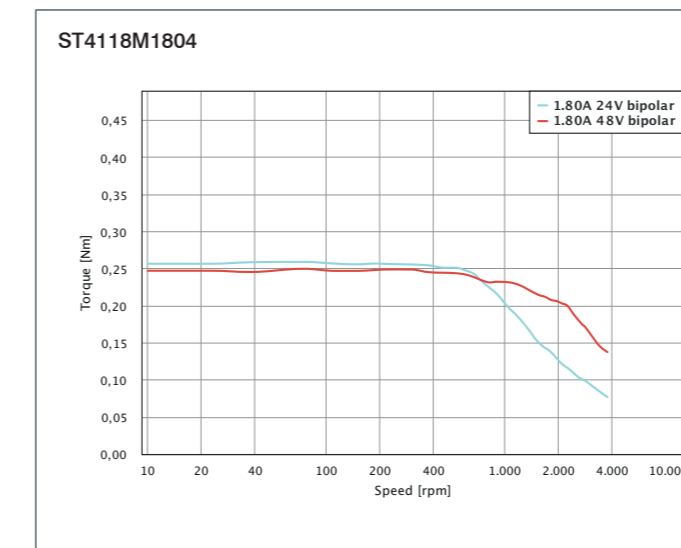
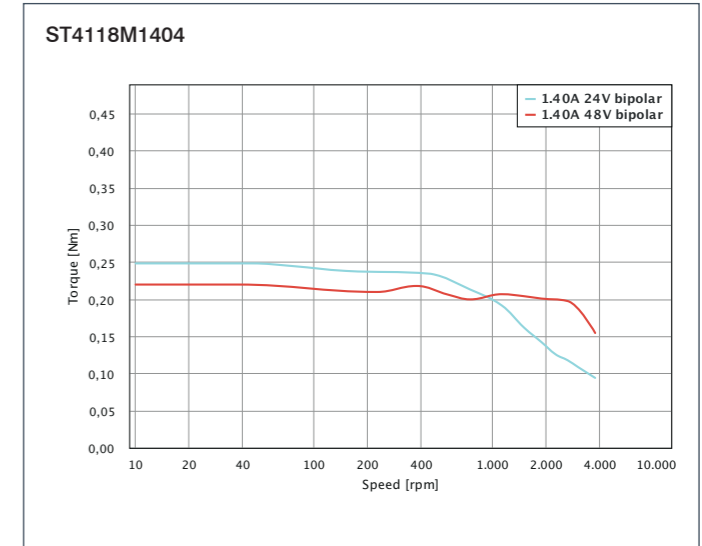
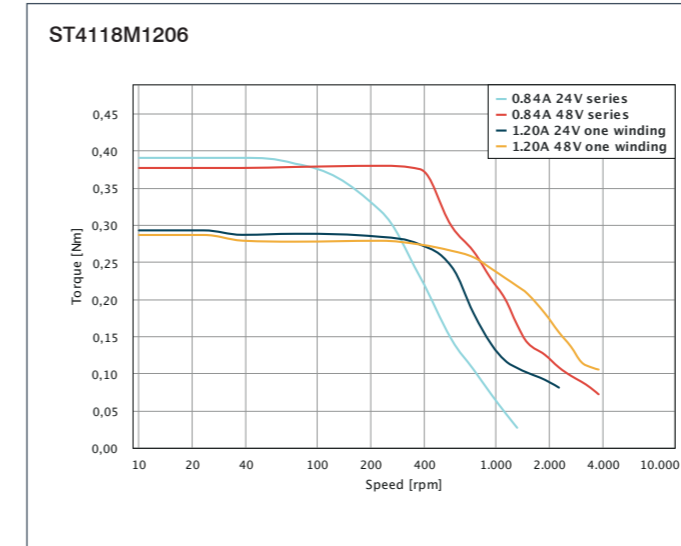
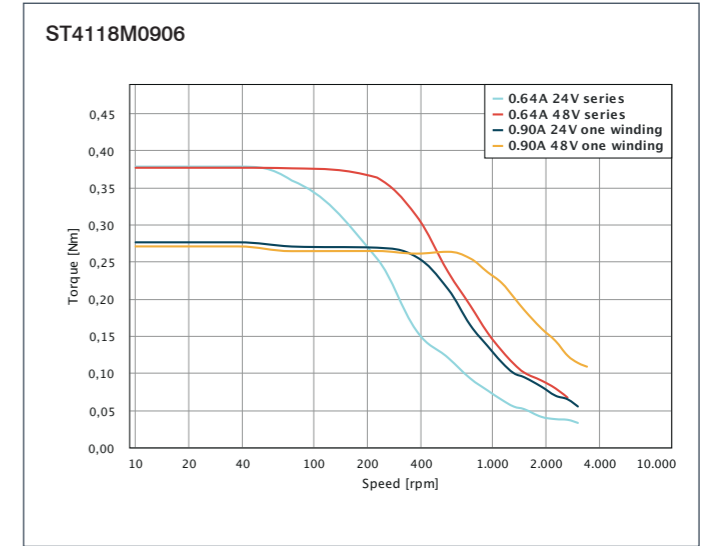
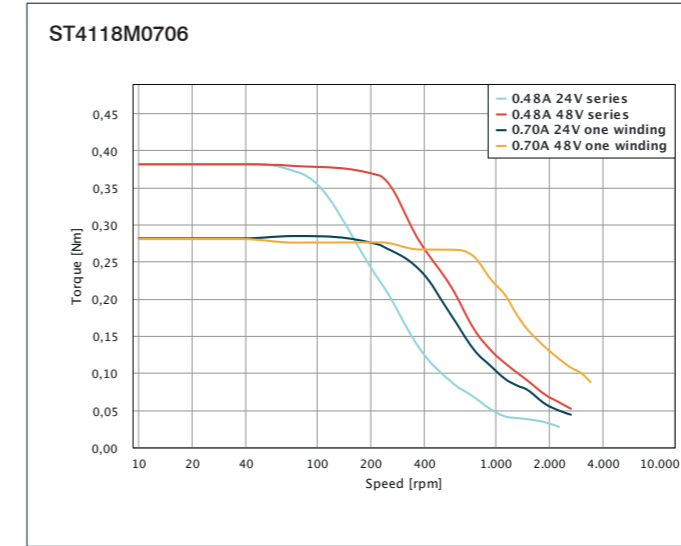



OPTIONS



VERSIONS

Type	Current per Winding A/Winding	Holding Torque Ncm	Resistance per Winding Ohm	Inductance per Winding mH	Rotor Inertia gcm ²	Weight kg	Length „A“ mm
ST4209X1004	1	17	8.7	18	20	0.15	22
ST4209S0404	0.42	17.6	13	7.5	35	0.22	34
ST4209S1006	0.67	21.21	4.2	4	35	0.22	34
ST4209S1404	1.33	22	2.1	5.2	35	0.22	34
ST4209M1206	0.85	35.36	3.3	4	54	0.28	40
ST4209M1704	1.68	36	1.65	4	54	0.28	40
ST4209L1206	0.85	43.84	3.3	4.8	68	0.35	48
ST4209L1704	1.68	44	1.65	5	68	0.35	47

The current and holding torque values refer to bipolar serial wiring. The resistance and inductance values refer to unipolar wiring.

ORDER IDENTIFIER

ST4209X1004-
A = single shaft
B = double shaft

ACCESSORIES

ZD-D40 Damper
ZD-DF40 Damper
ZK-JST-VL-4 Cable for XHP4 Plug
ZK-JST-VL-6 Cable for XHP6 Plug

DIMENSIONS (IN MM)

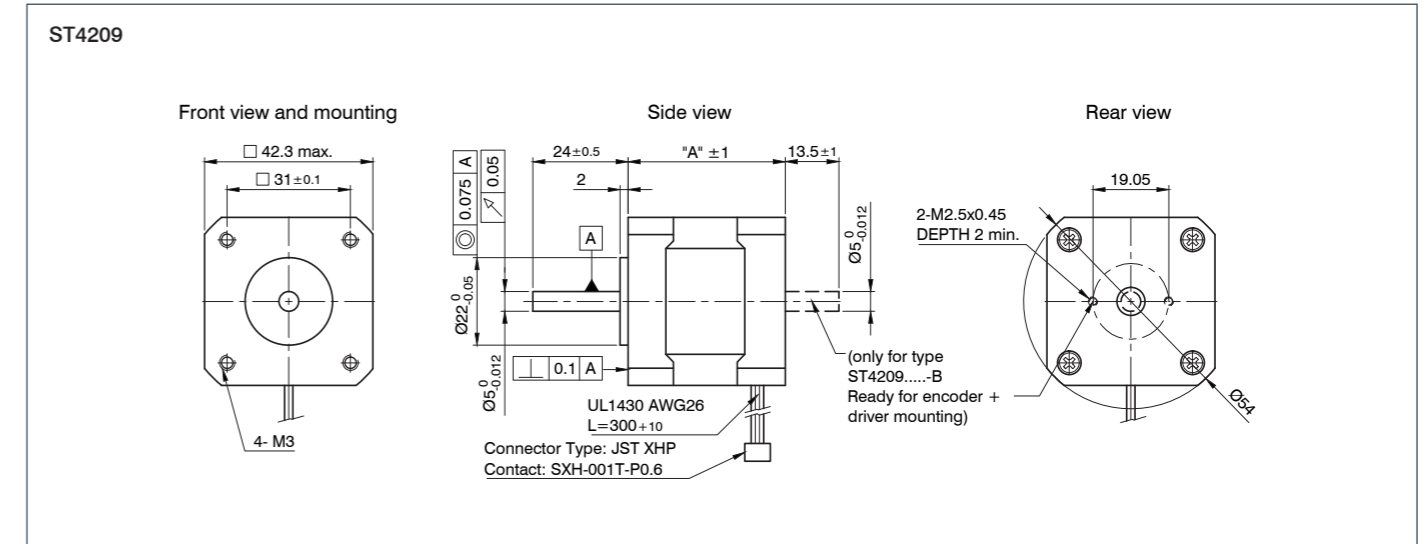

TORQUE CURVES

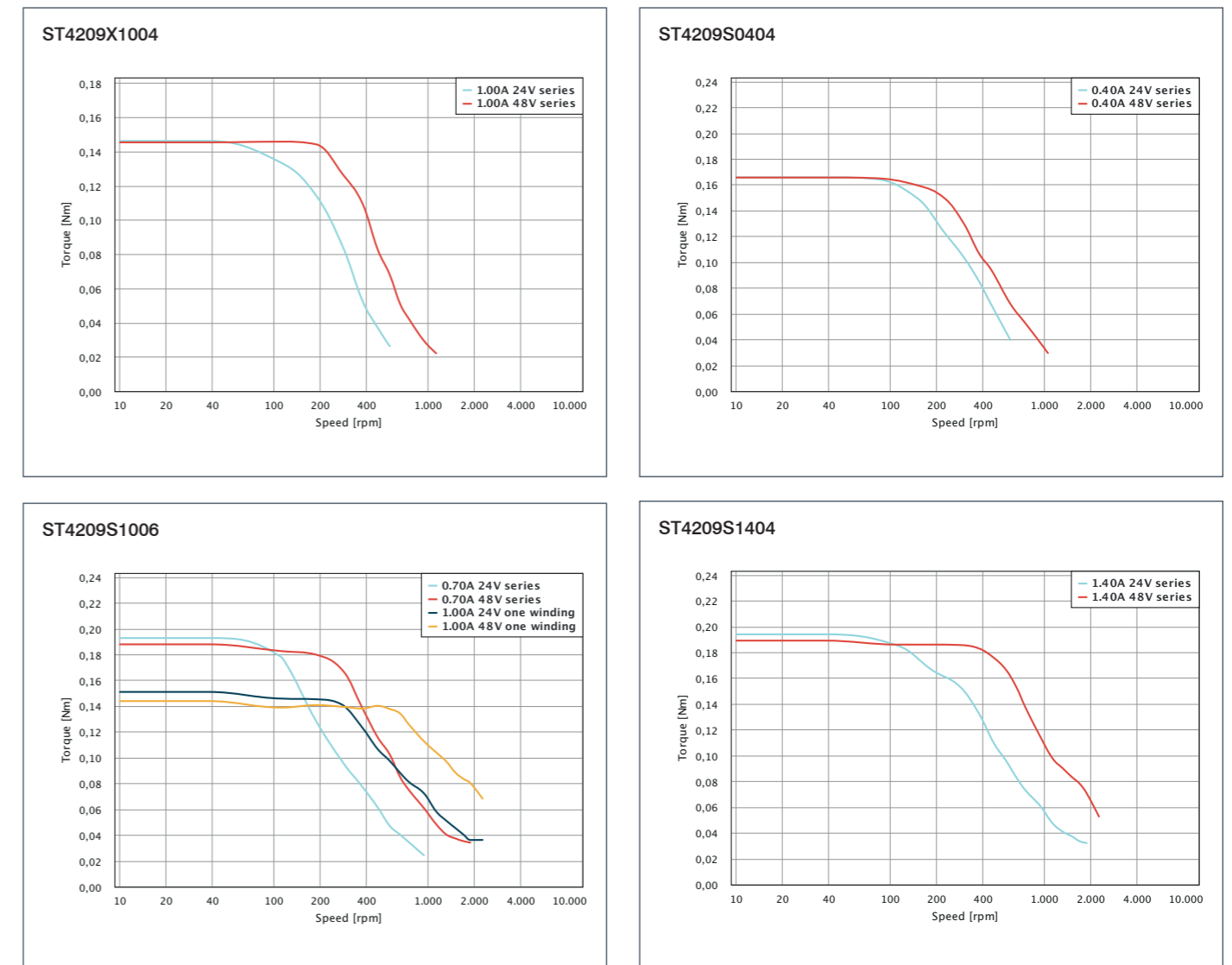



OPTIONS



VERSIONS

Type	Current per Winding A/Winding	Holding Torque Ncm	Resistance per Winding Ohm	Inductance per Winding mH	Rotor Inertia gcm ²	Weight kg	Length „A“ mm
ST5918X1008	0.71	53.74	5	5.4	135	0.49	41
ST5918X2008	1.41	53.74	1.2	1.3	135	0.49	41
ST5918X3008	2.12	53.74	0.5	0.54	135	0.49	41
ST5918S1008	0.71	98.99	6.2	7.5	275	0.65	51
ST5918S2008	1.41	98.99	1.5	2.6	275	0.65	51
ST5918S3008	2.12	98.99	0.72	0.9	275	0.65	51
ST5918M1008	0.71	124.45	6.9	14	300	0.7	56
ST5918M2008	1.41	124.45	1.7	2.5	300	0.7	56
ST5918M3008	2.12	124.45	0.7	1.3	300	0.7	56
ST5918L1008	0.71	186.68	8.8	19	480	1	76
ST5918L2008	1.41	186.68	2.4	5.1	480	1	76
ST5918L3008	2.12	186.68	1	2.2	480	1	76
ST5918L4508	3.18	186.68	0.5	0.95	480	1	76

The current and holding torque values refer to bipolar serial wiring. The resistance and inductance values refer to unipolar wiring.

ORDER IDENTIFIER

ST5918X1008-
A = single shaft
B = double shaft

ACCESSORIES

ZD-D56 Damper
ZD-DF56 Damper

DIMENSIONS (IN MM)

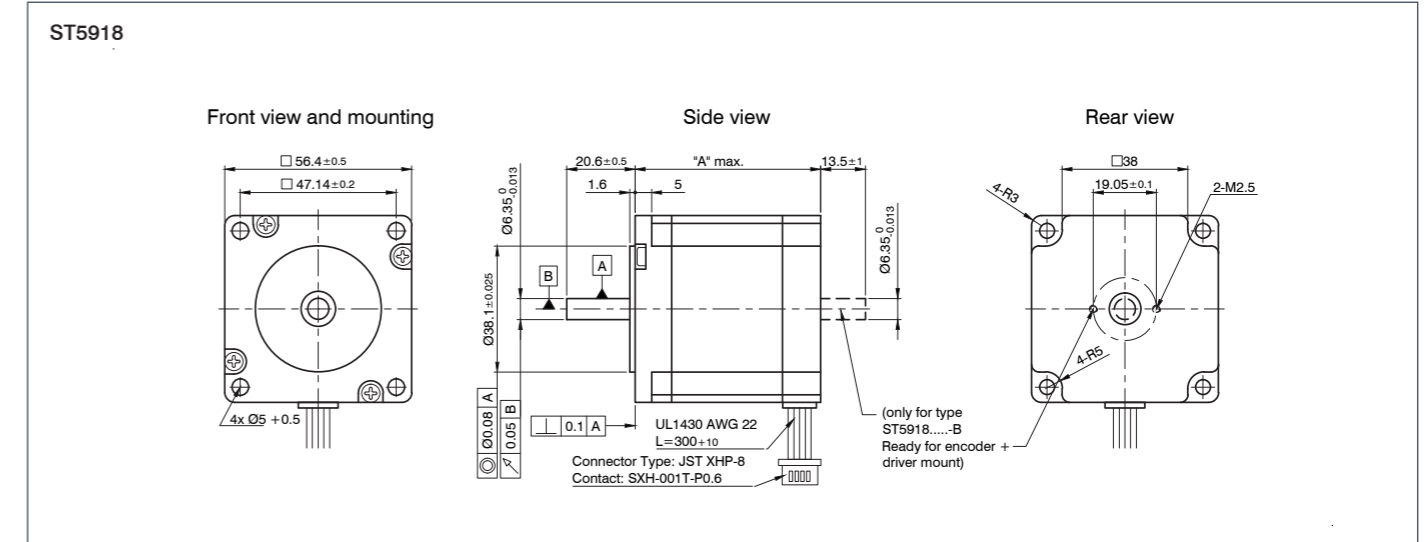

TORQUE CURVES

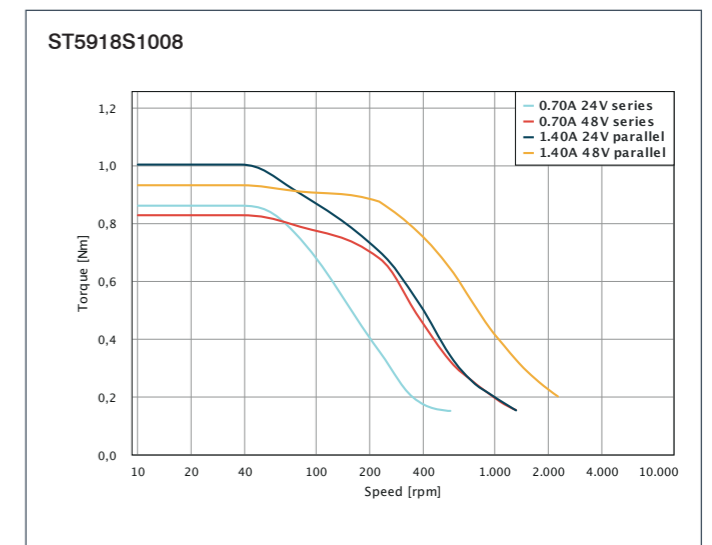
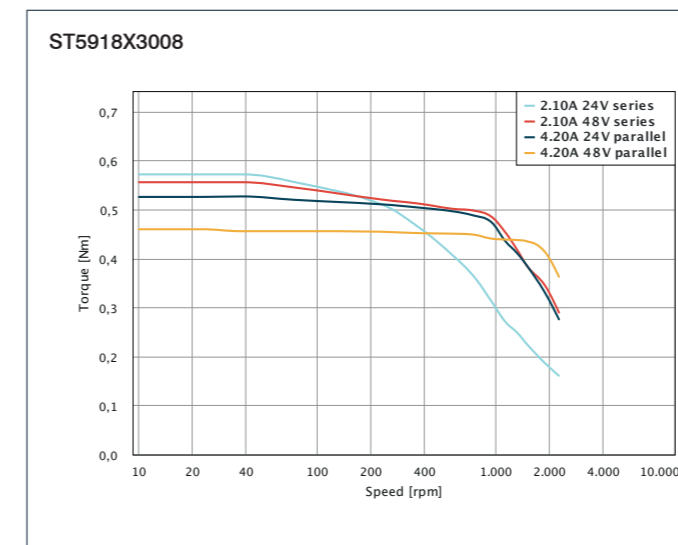
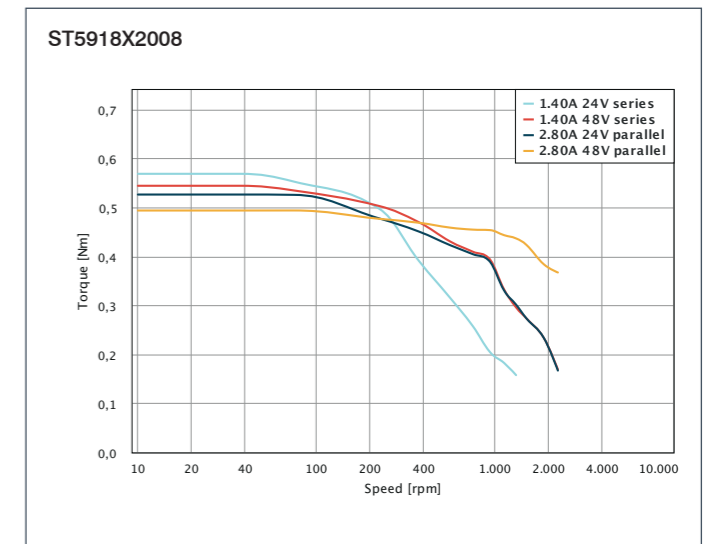
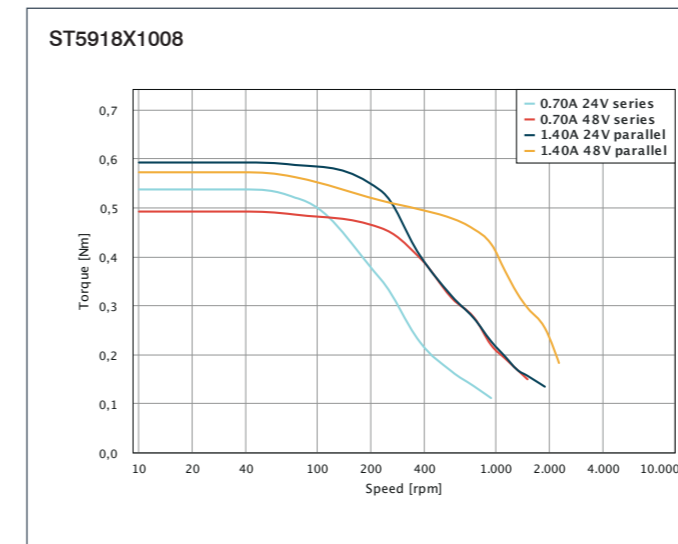

TORQUE CURVES

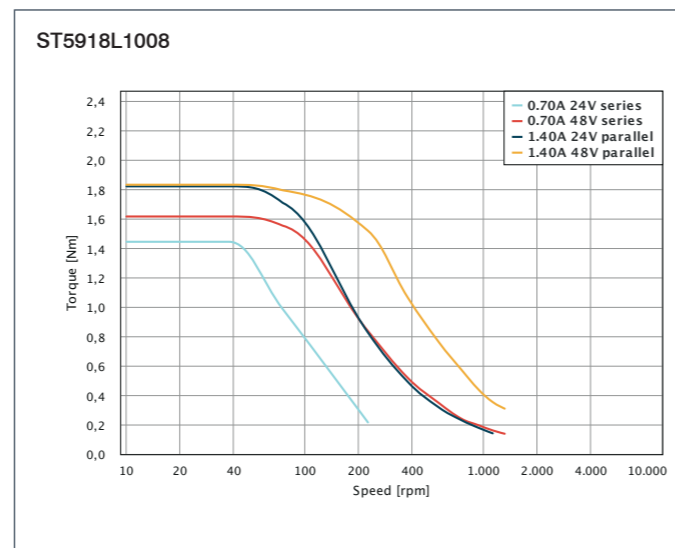
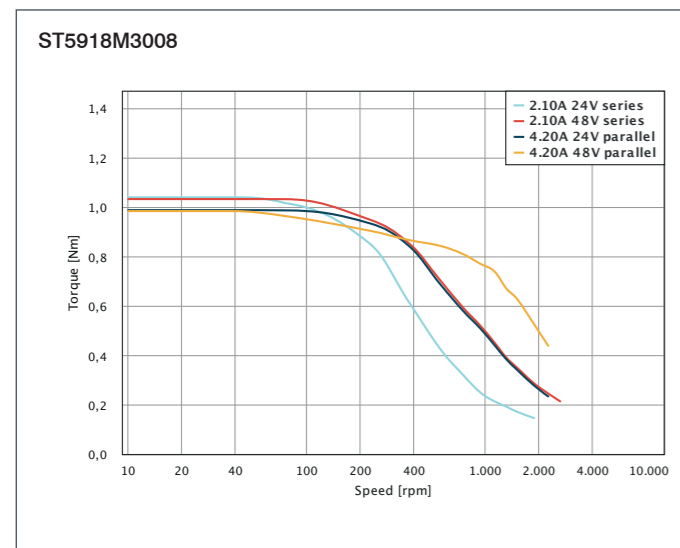
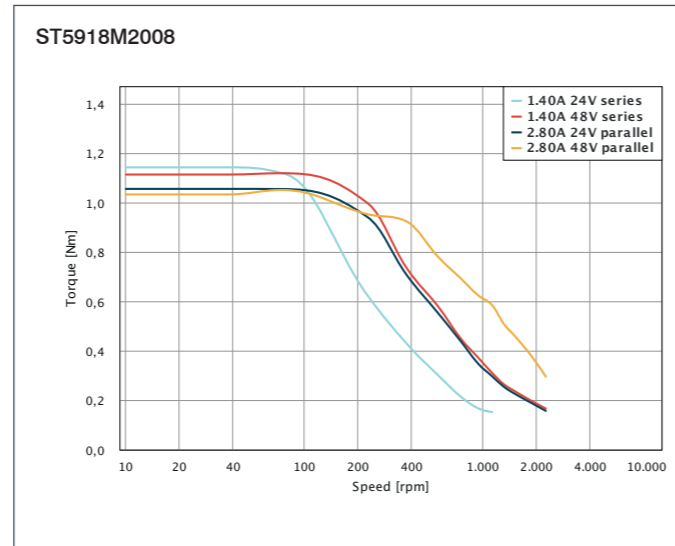
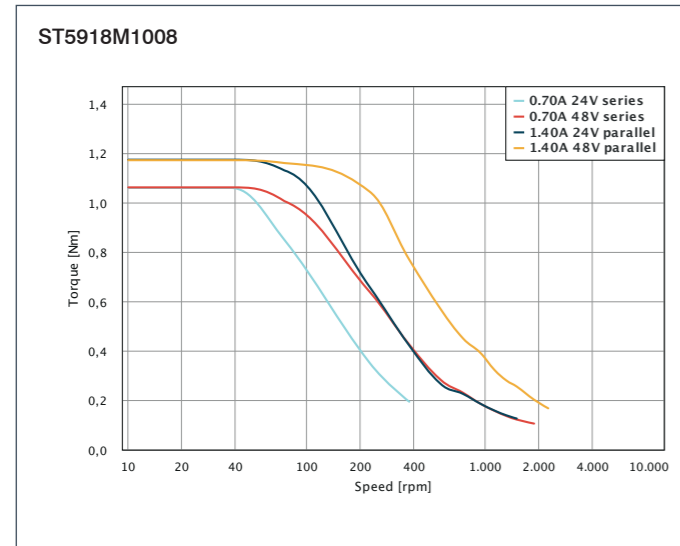
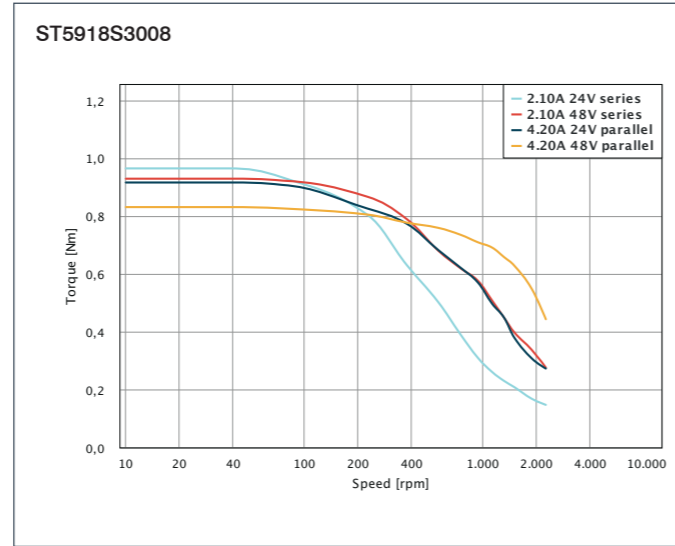
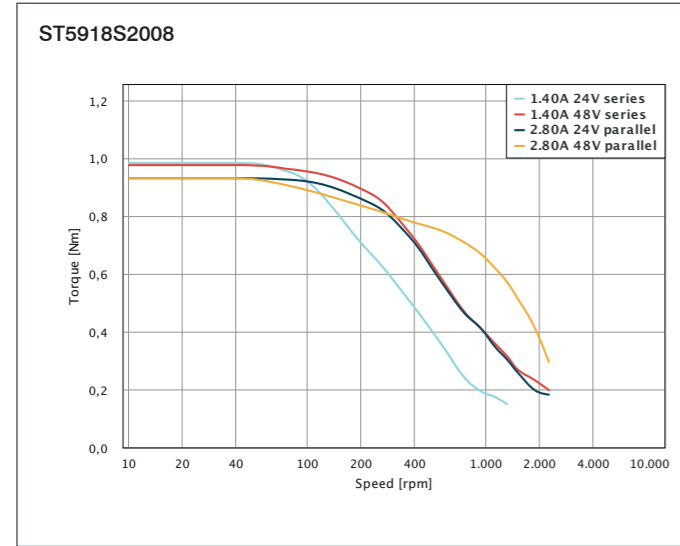

TORQUE CURVES

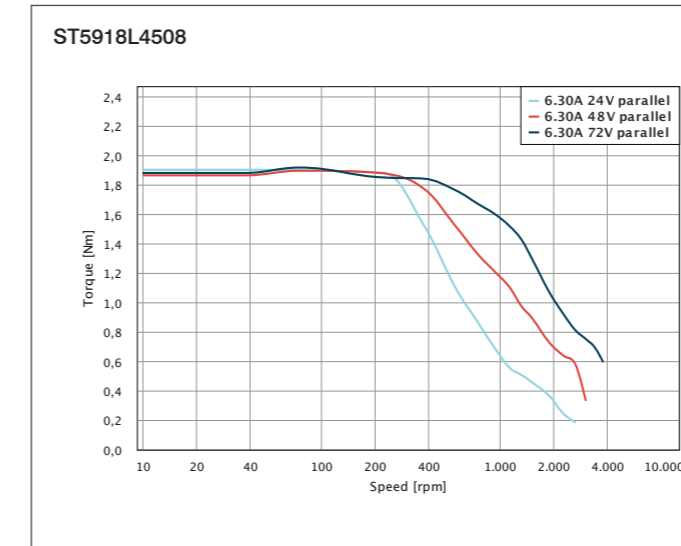
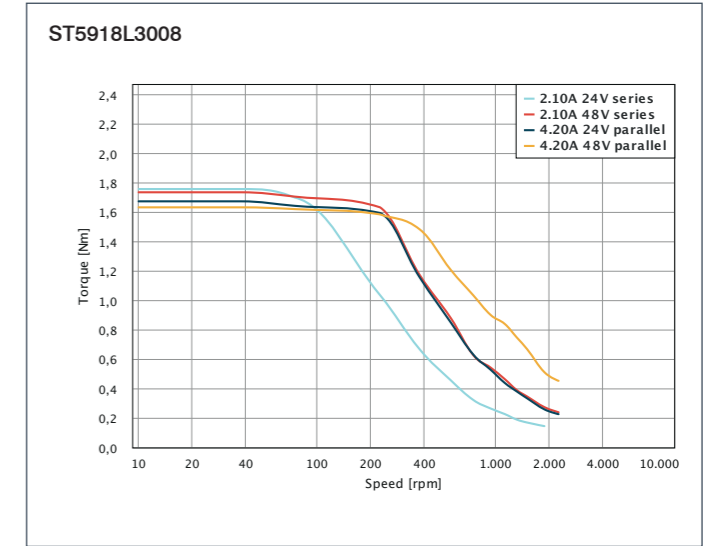
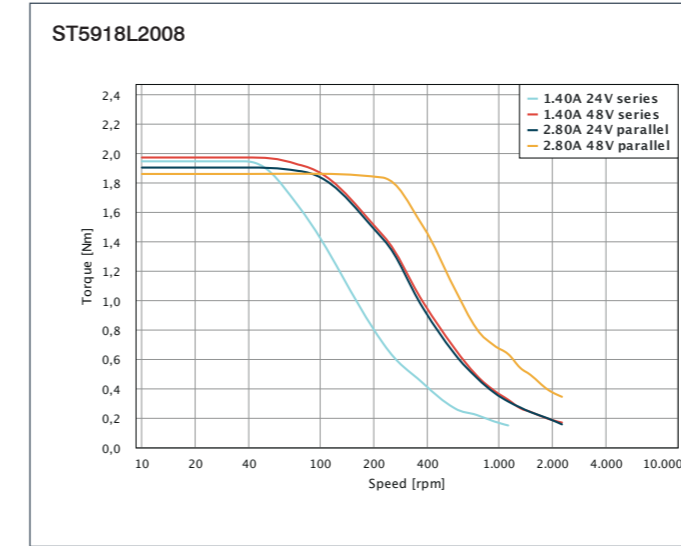



OPTIONS



VERSIONS

Type	Current per Winding A/Winding	Holding Torque Ncm	Resistance per Winding Ohm	Inductance per Winding mH	Rotor Inertia gcm ²	Weight kg	Length „A“ mm
ST6018X2008	1.41	106.07	1.46	2.2	275	0.6	47
ST6018X3008	2.12	110.31	0.68	0.8	275	0.6	47
ST6018M2008	1.41	195.16	2	4.6	400	0.77	56
ST6018M3008	2.12	165.46	0.8	1.38	400	0.77	56
ST6018K2008	1.41	212.13	2.4	4.6	570	1.2	67
ST6018L3008	2.12	353.55	1.3	3.2	840	1.45	88
ST6018D4508	3.18	400.22	0.75	1.4	1100	1.9	111

The current and holding torque values refer to bipolar serial wiring. The resistance and inductance values refer to unipolar wiring.

ORDER IDENTIFIER



ST6018X2008-

A = single shaft

B = double shaft

DIMENSIONS (IN MM)

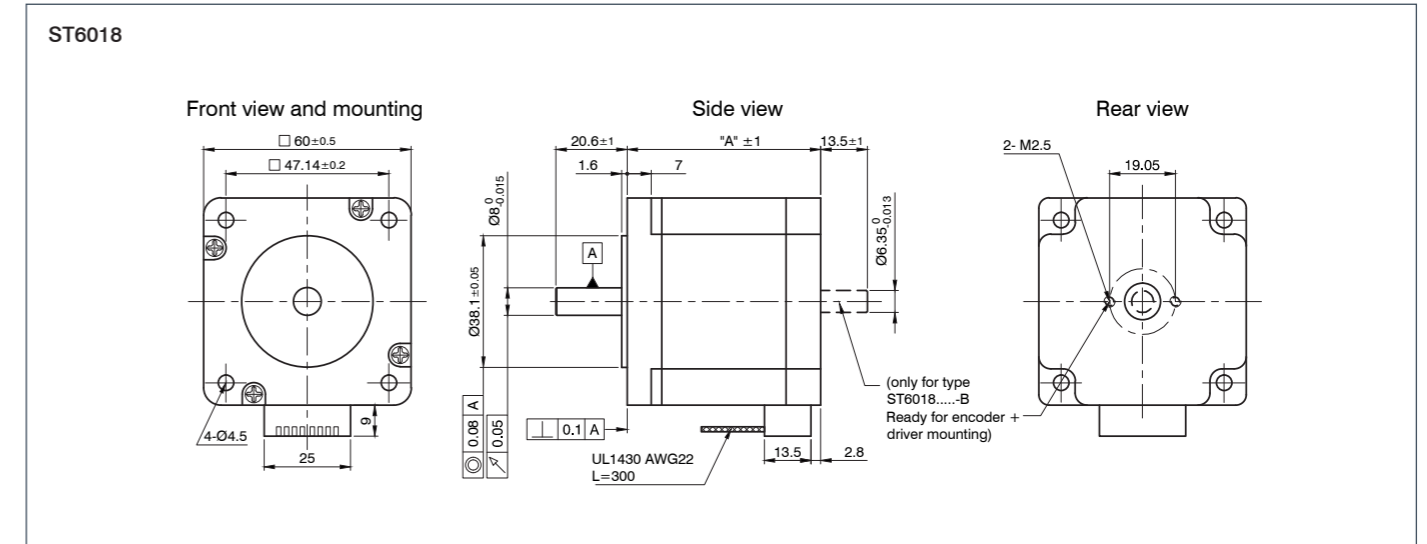

TORQUE CURVES

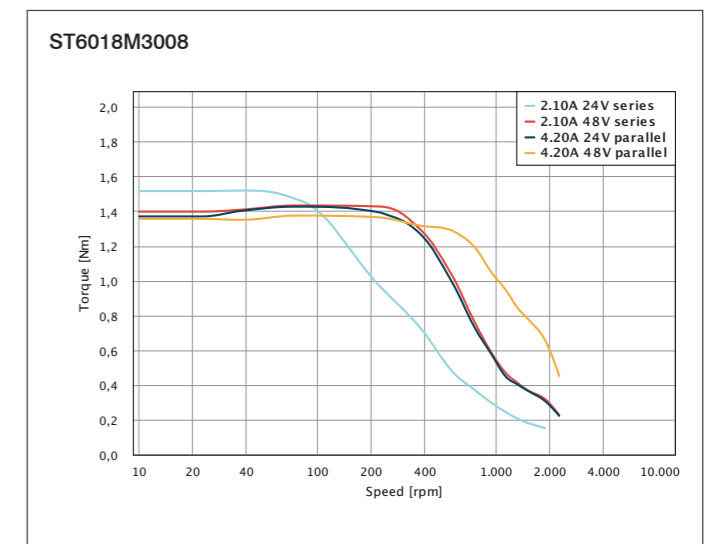
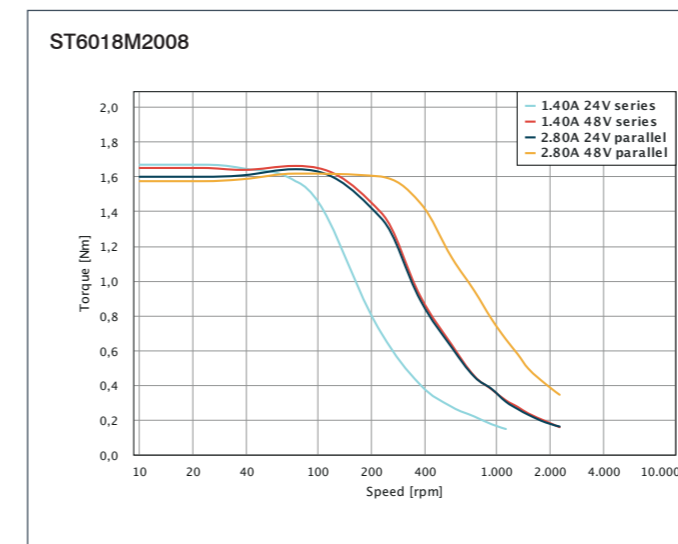
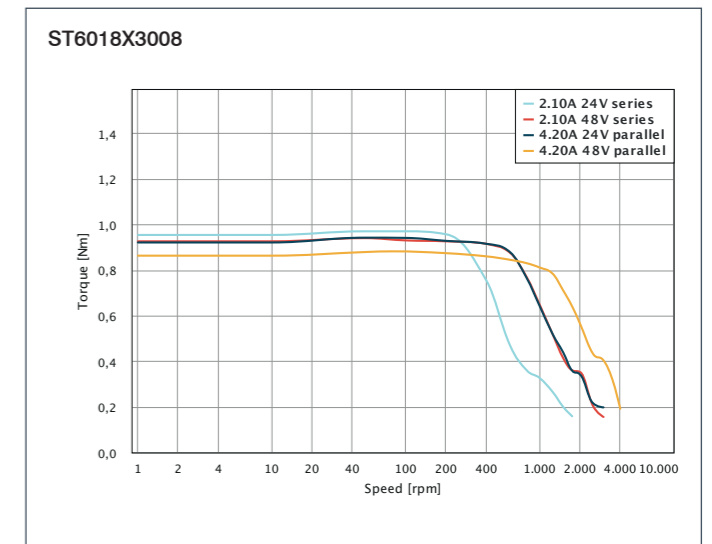
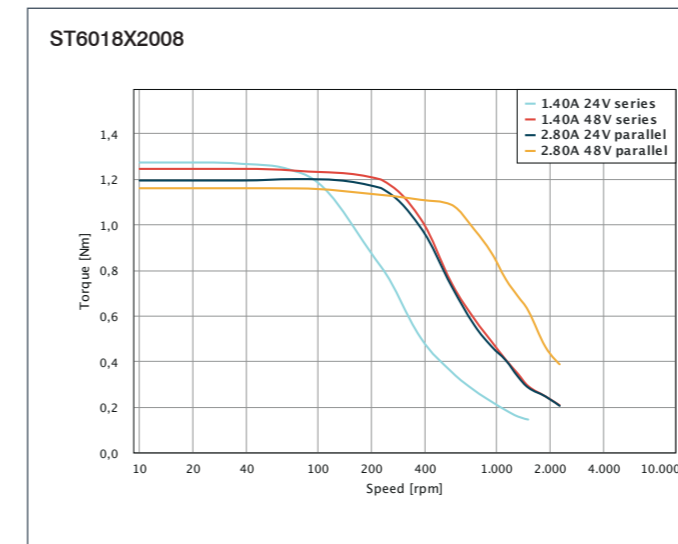

TORQUE CURVES

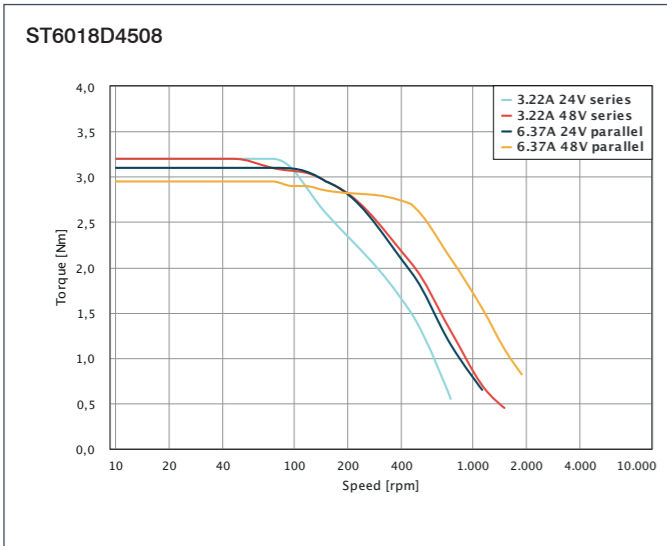
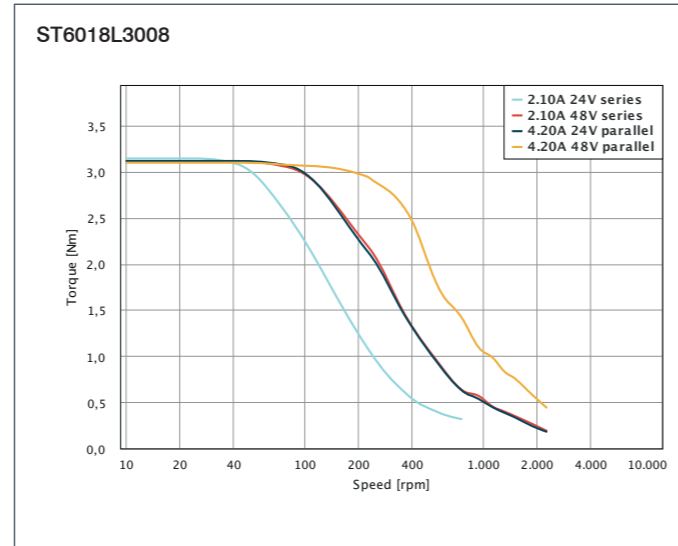
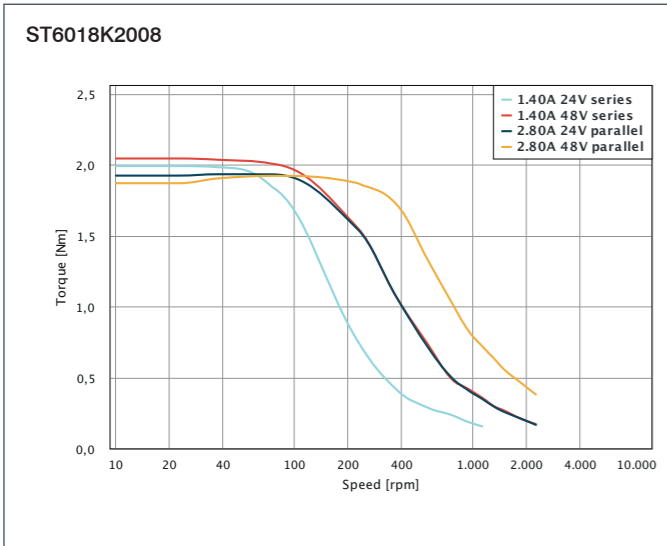

Notes section with horizontal lines for writing.



OPTIONS



VERSIONS

Type	Current per Winding A/Winding	Holding Torque Ncm	Resistance per Winding Ohm	Inductance per Winding mH	Rotor Inertia gcm ²	Weight kg	Length „A“ mm
ST8918S4508	3.18	353.55	0.6	1.9	1000	1.7	65
ST8918M4508	3.18	593.97	0.66	3	1900	2.8	96
ST8918M6708	4.74	593.97	0.45	2.6	1900	2.8	96
ST8918L4508	3.18	933.38	1.1	6.3	3000	3.95	126
ST8918L6708	4.74	933.38	0.54	2.7	3000	3.95	126
ST8918D6708	4.74	1343.5	0.75	4.9	4000	5.4	156

The current and holding torque values refer to bipolar serial wiring. The resistance and inductance values refer to unipolar wiring.

ORDER IDENTIFIER

ST8918S4508-

A = single shaft

B = double shaft

DIMENSIONS (IN MM)

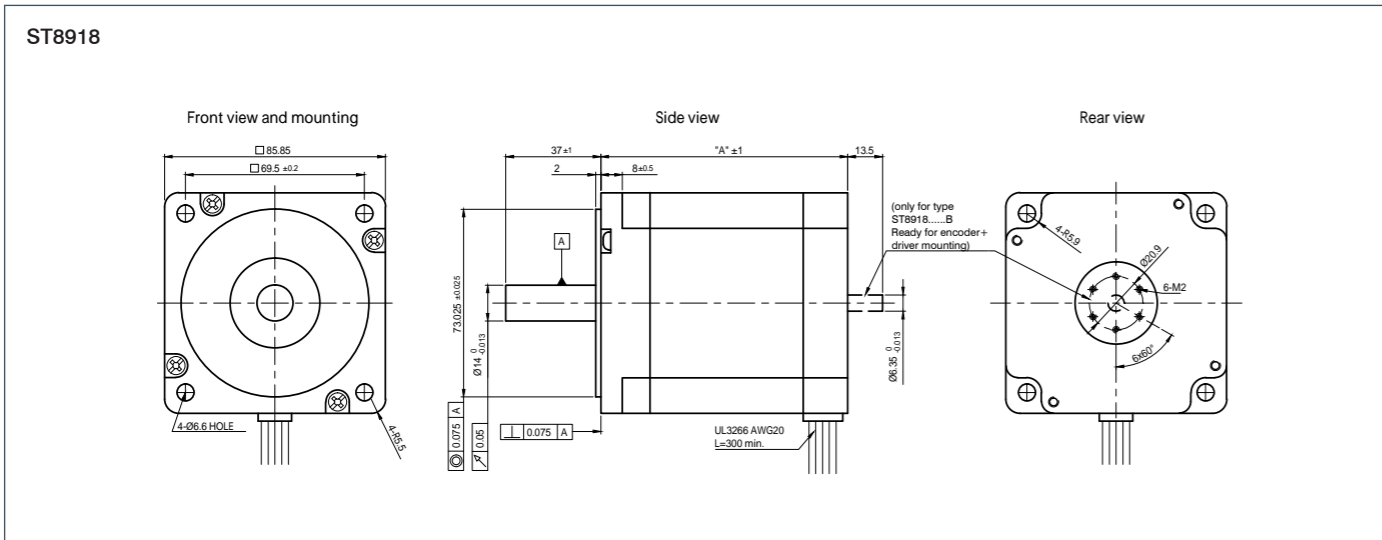

TORQUE CURVES

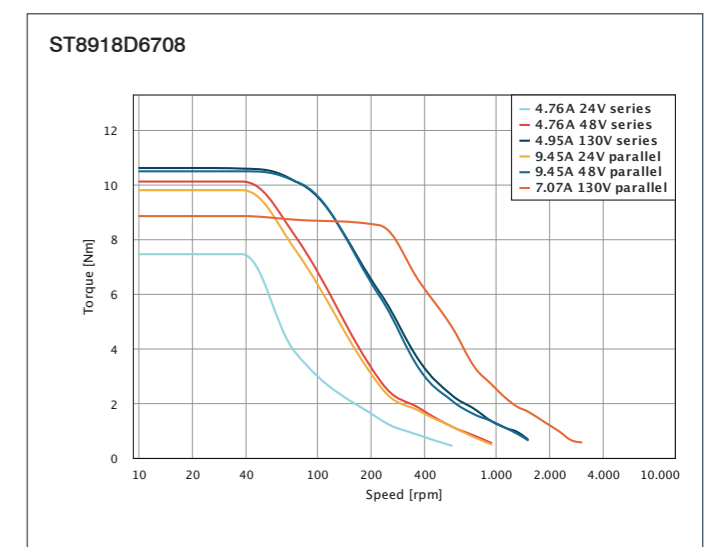
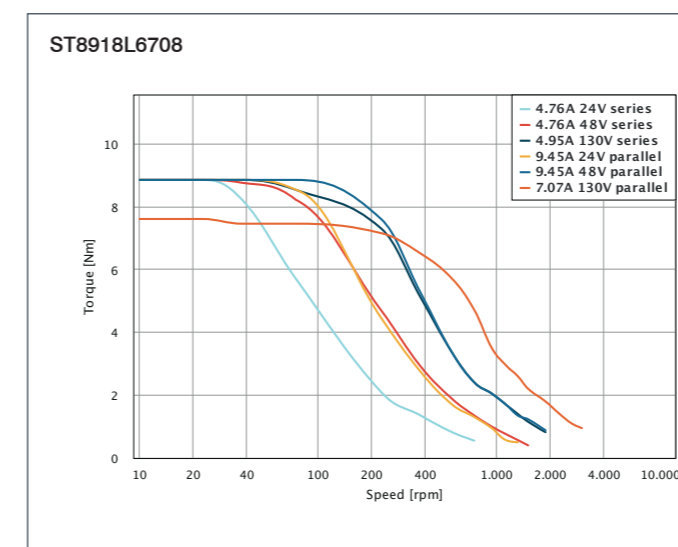
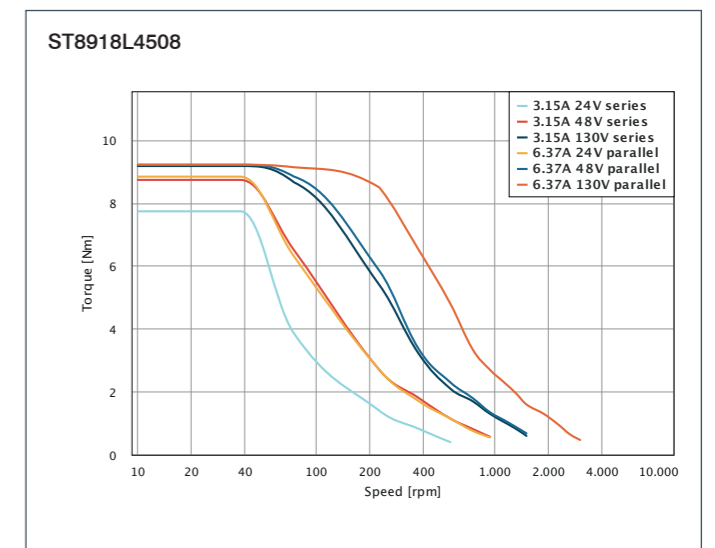
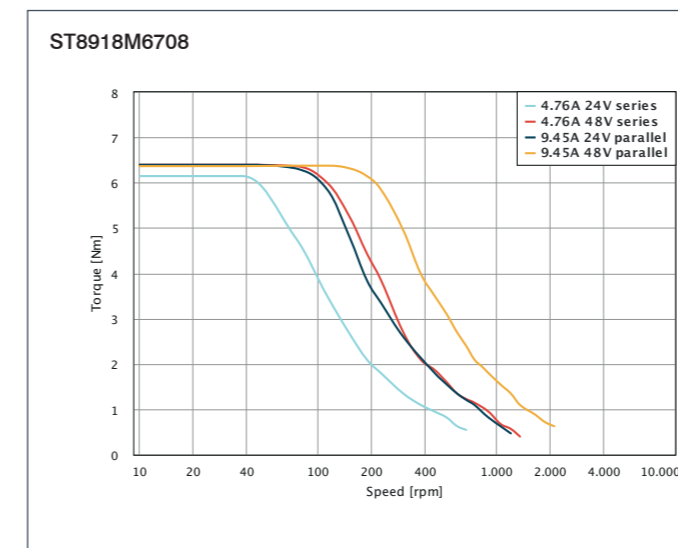
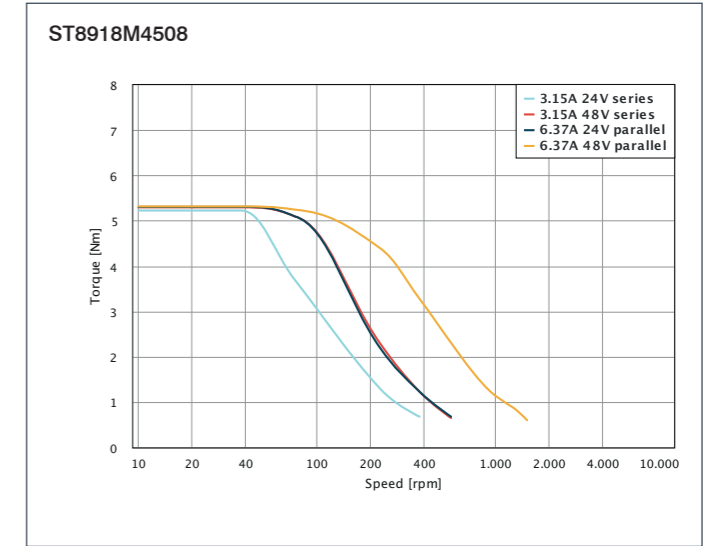
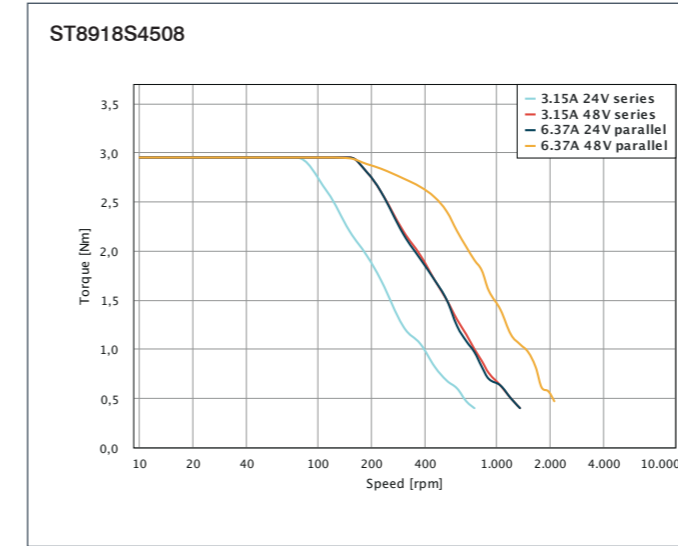

ST11018

Stepper Motor - NEMA 42



OPTIONS



VERSIONS

Type	Current per Winding A/Winding	Holding Torque Ncm	Resistance per Winding Ohm	Inductance per Winding mH	Rotor Inertia gcm ²	Weight kg	Length „A“ mm
ST11018S5504	4.5	1170	0.7	9.8	5500	5	99
ST11018M6504	4.5	2100	1.15	15.2	10900	8.4	150
ST11018L8004	8	2500	1	17.1	16200	11.7	201

ORDER IDENTIFIER

ST11018S5504-
 A = single shaft
 B = double shaft

DIMENSIONS (IN MM)

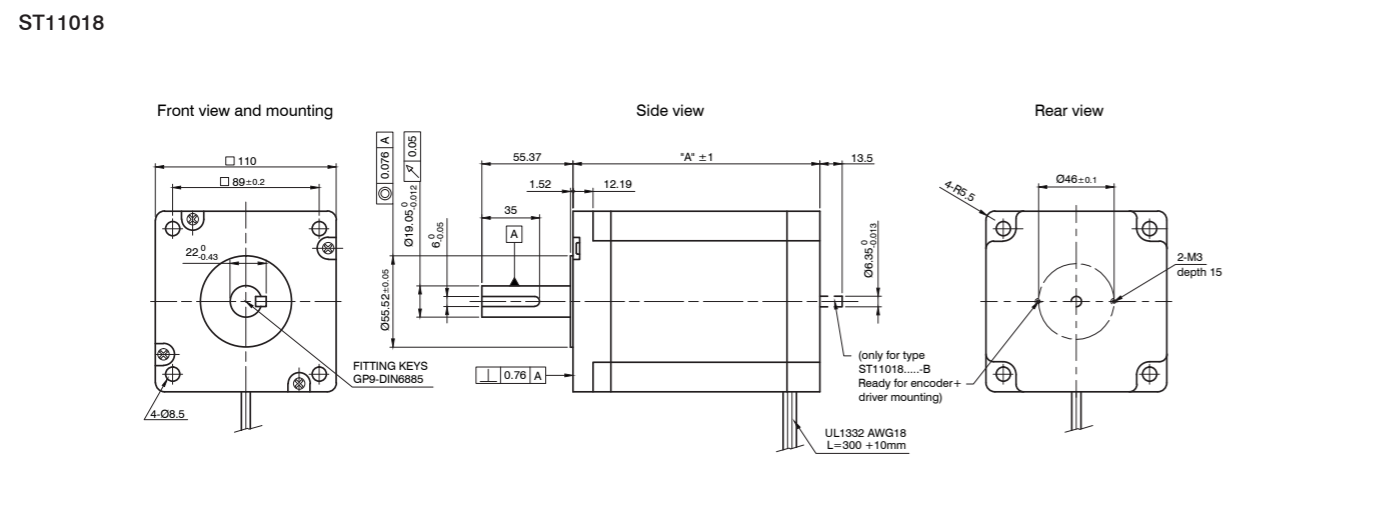

ST11018

Stepper Motor - NEMA 42



TORQUE CURVES

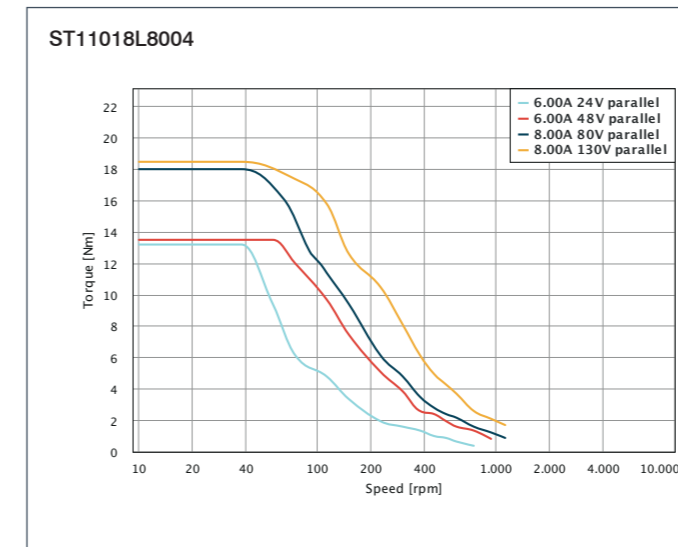
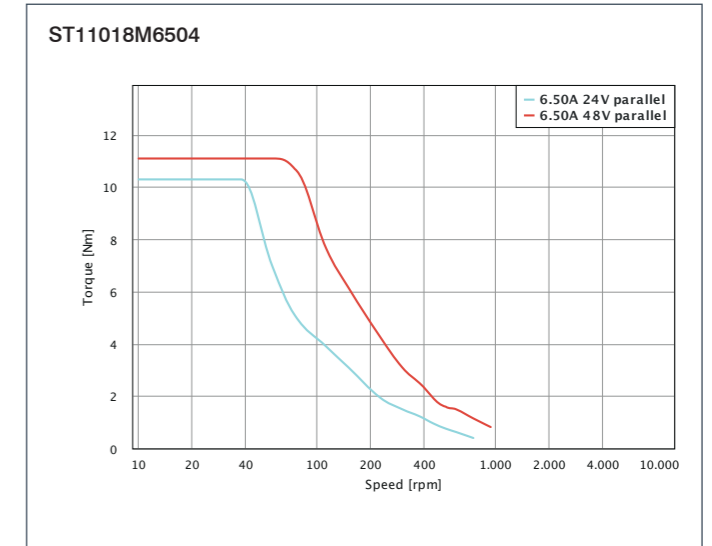
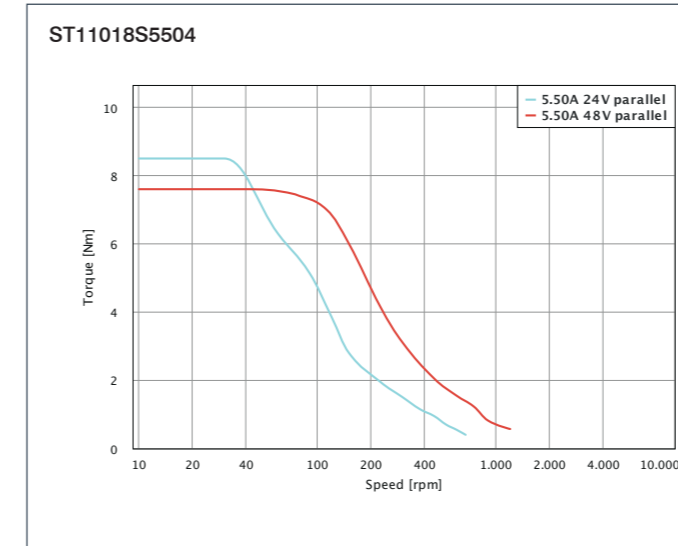



OPTIONS



VERSIONS

Type	Current per Winding A/Winding	Holding Torque Ncm	Resistance per Winding Ohm	Inductance per Winding mH	Rotor Inertia gcm ²	Weight kg	Length „A“ mm
SC6018L4204	4.2	354	0.65	3.2	840	1.4	100

ORDER IDENTIFIER

SC6018L4204-
 ENO05K = 5 V Encoder Type
 ENO24K = 24 V Encoder Type

ACCESSORIES

ZK-NOE1-10-500-S Encoder Cable
ZK-JST-VHR-6N-0.5M-S Connection cable
ZK-JST-VHR-6N-2M-S Connection cable

DIMENSIONS (IN MM)

SC6018L4204-EN

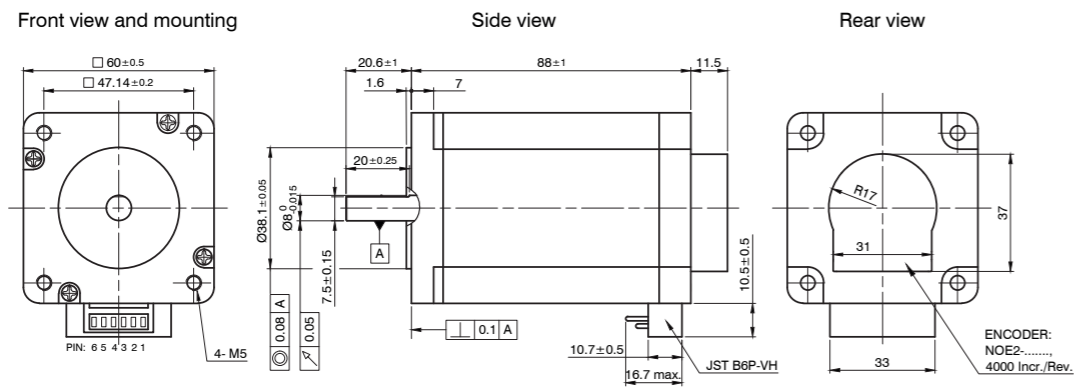

TORQUE CURVES

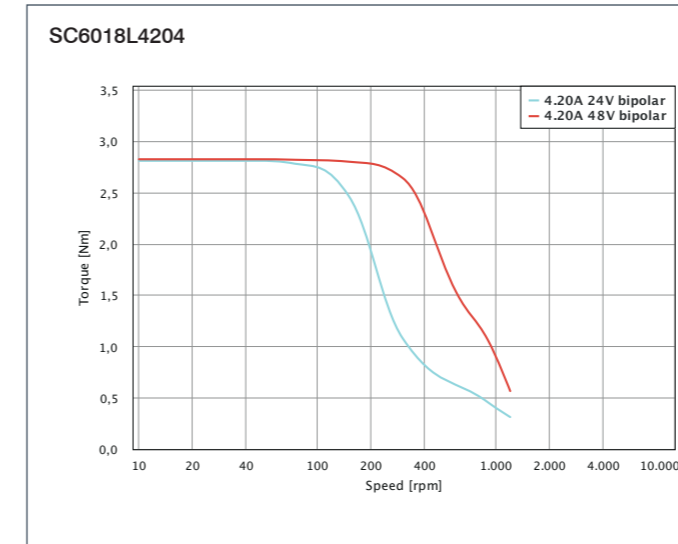



OPTIONS



DESCRIPTION

2-phase, high-torque stepper motor in size NEMA 11 (28 mm) and with a step angle (full step) of 1.8° in protection class IP65 (except for shaft outlet). This motor will work as a replacement for the standard motor ST2818 as they have the same flange size.

VERSIONS

Type	Current per Winding A/Winding	Holding Torque Ncm	Resistance per Winding Ohm	Inductance per Winding mH	Rotor Inertia gcm ²	Weight kg	Length „A“ mm
AS2818S0604	0.67	7.1	5.6	4	9	0.13	51
AS2818L0604	0.67	12.7	9.2	7.2	18	0.22	70

ORDER IDENTIFIER

AS2818S0604

ACCESSORIES

- ZK-M12-5-2M-1-PUR-S M12 Cable
- ZK-M12-5-2M-2-PUR-S M12 Cable
- ZK-M12-5-5M-1-PUR-S M12 Cable
- ZK-M12-5-5M-2-PUR-S M12 Cable
- ZK-M12-8-2M-1-PUR-S M12 Cable
- ZK-M12-8-2M-2-PUR-S M12 Cable
- ZK-M12-8-5M-1-PUR-S M12 Cable
- ZK-M12-8-5M-2-PUR-S M12 Cable

DIMENSIONS (IN MM)

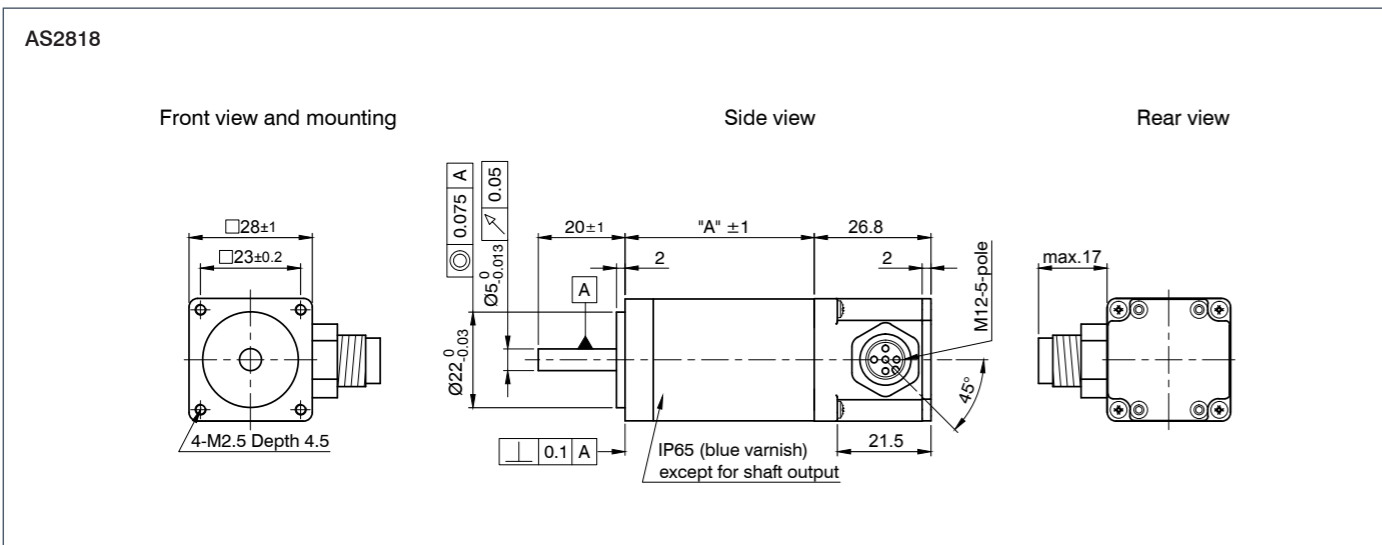

TORQUE CURVES

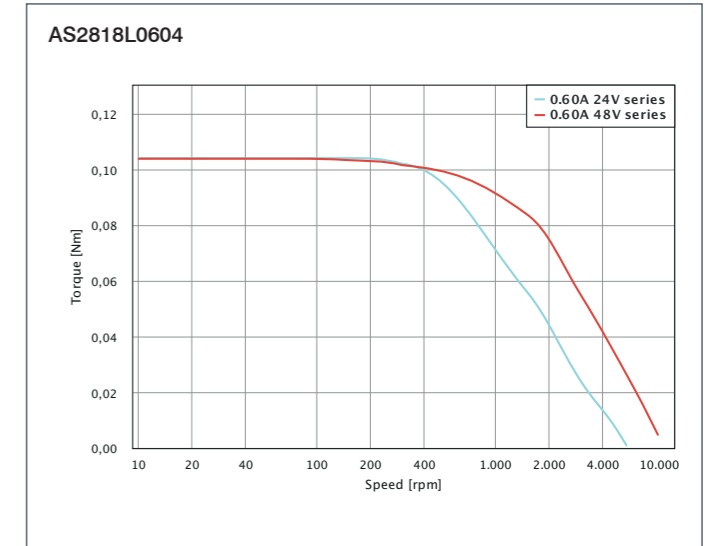
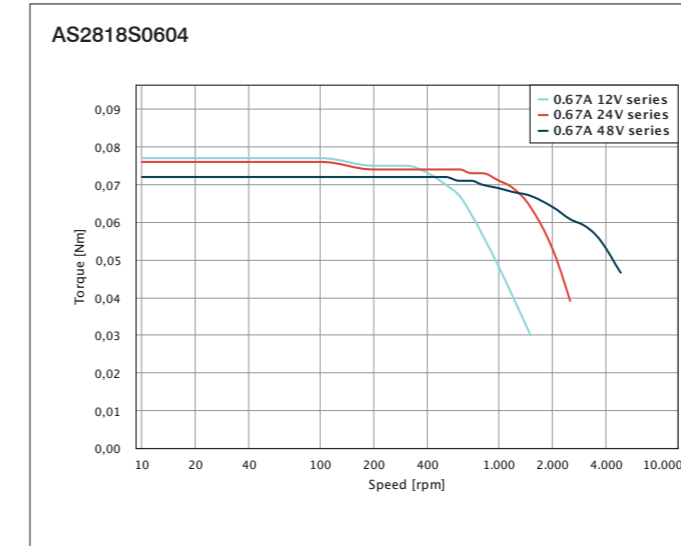



OPTIONS



DESCRIPTION

2-phase, high-torque stepper motor in size NEMA 17 (42 mm) and with a step angle (full step) of 1.8° in protection class IP65 (except for shaft outlet). This motor will work as a replacement for the standard motor ST4118 as they have the same flange size.

VERSIONS

Type	Current per Winding A/Winding	Holding Torque Ncm	Resistance per Winding Ohm	Inductance per Winding mH	Rotor Inertia gcm ²	Weight kg	Length „A“ mm	Encoder Type V	Brake Torque Nm
AS4118L1804	1.8	50	1.75	3.3	82	0.34	70.4		
AS4118L1804-E	1.8	50	1.75	3.3	82	0.34	70.4	5	
AS4118L1804-EB	1.8	50	1.75	3.3	82	0.42	106.4	5	0.4
AS4118L1804-ENM24	1.8	50	1.75	3.3	82	0.34	70.4	24	

ORDER IDENTIFIER

AS4118L1804-
 E = with Encoder
 EB = with Encoder and Bremse
 ENM24 = with 24V Encoder

ACCESSORIES

ZK-M12-5-2M-1-PUR-S M12 Cable
 ZK-M12-5-2M-2-PUR-S M12 Cable
 ZK-M12-5-5M-1-PUR-S M12 Cable
 ZK-M12-5-5M-2-PUR-S M12 Cable
 ZK-M12-8-2M-1-PUR-S M12 Cable
 ZK-M12-8-2M-2-PUR-S M12 Cable
 ZK-M12-8-5M-1-PUR-S M12 Cable
 ZK-M12-8-5M-2-PUR-S M12 Cable

DIMENSIONS (IN MM)

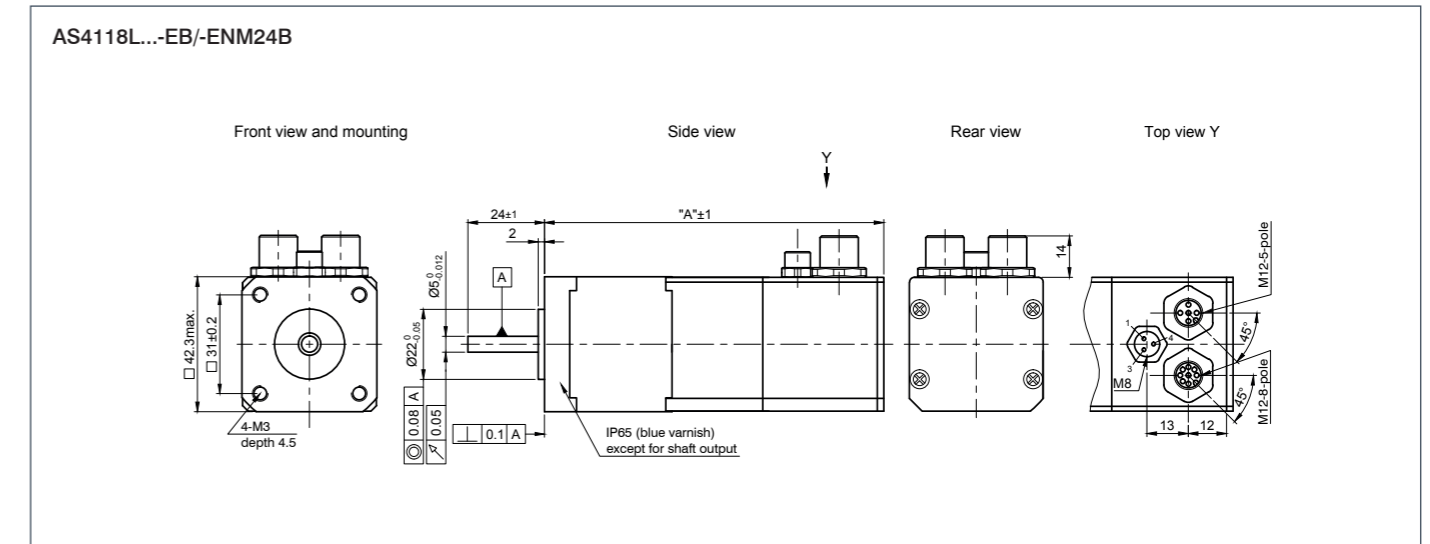
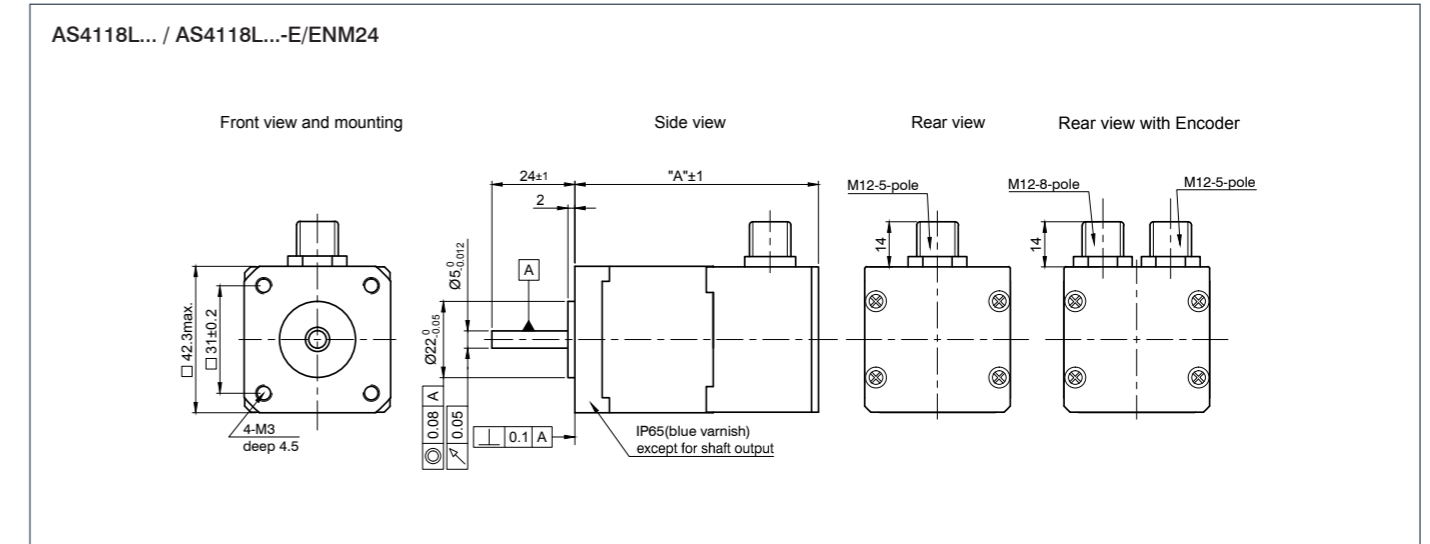

Stepper Motor with M12 Connector in Protection Class IP65

TORQUE CURVES

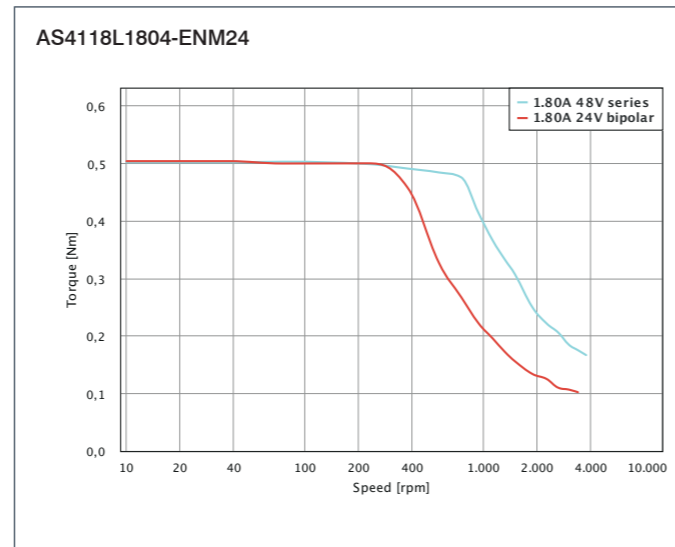
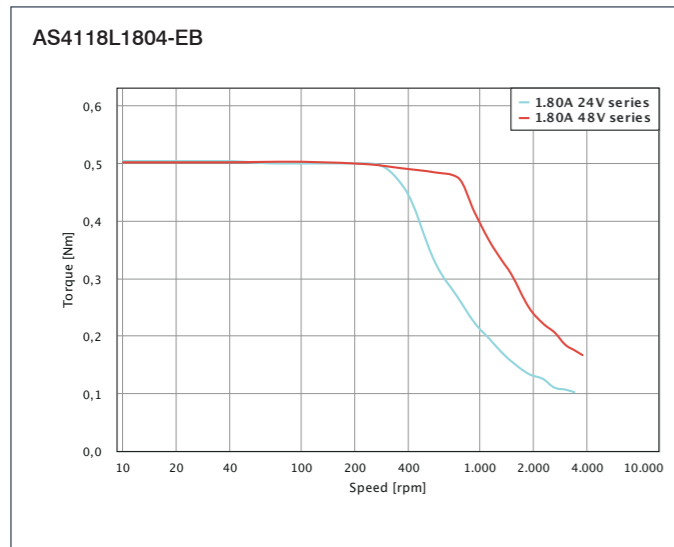
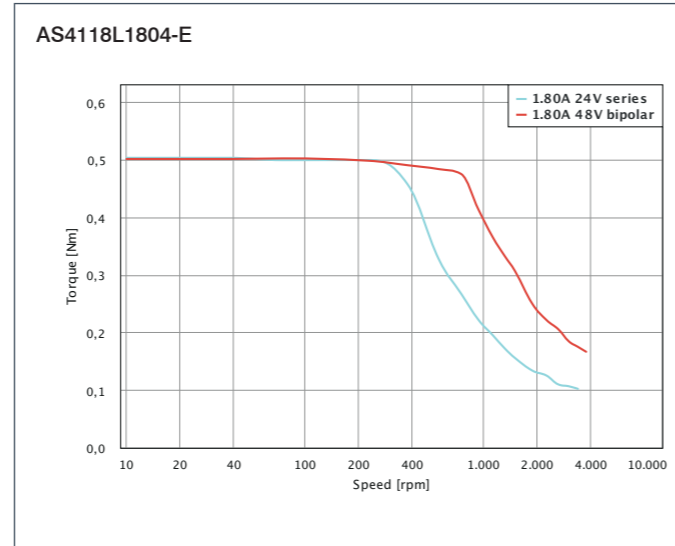
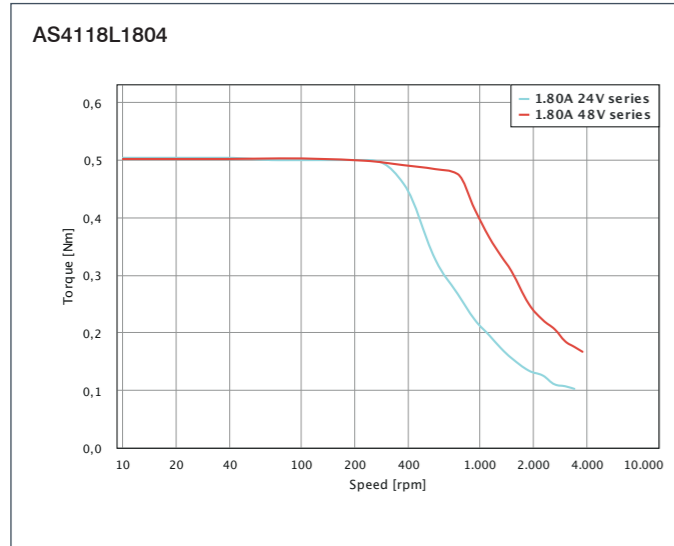

Notes section with horizontal lines for writing.



OPTIONS



DESCRIPTION

2-phase, high-torque stepper motor in size NEMA 23 (56 mm) and with a step angle (full step) of 1.8° in protection class IP65 (except for shaft outlet). This motor will work as a replacement for the standard motor ST5918 as they have the same flange size.

VERSIONS

Type	Current per Winding A/Winding	Holding Torque Ncm	Resistance per Winding Ohm	Inductance per Winding mH	Rotor Inertia gcm ²	Weight kg	Length „A“ mm	Encoder Type V	Brake Torque Nm
AS5918S2804	2.83	85	0.75	2.6	230	0.8	73		
AS5918S2804-E	2.83	85	0.75	2.6	230	0.8	73	5	
AS5918M2804	2.83	105	0.85	3.6	300	0.85	77		
AS5918M2804-E	2.83	105	0.85	3.6	300	0.85	77	5	
AS5918L4204	4.2	198	0.5	1.9	480	1.14	98		
AS5918L4204-E	4.2	198	0.5	1.9	480	1.14	98	5	
AS5918L4204-EB	4.2	198	0.5	1.9	480	1.33	138	5	1
AS5918L4204-ENM24	4.2	198	0.5	1.9	480	1	98	24	
AS5918L4204-ENM24B	4.2	198	0.5	1.9	480	1	138	24	1

ORDER IDENTIFIER

AS5918S2804-
 E = with Encoder
 EB = with Encoder and Brake
 ENM24 = with 24V Encoder
 ENM24B = with 24V Encoder and Brake

ACCESSORIES

ZK-M12-5-2M-1-PUR-S M12 Cable
ZK-M12-5-2M-2-PUR-S M12 Cable
ZK-M12-5-5M-1-PUR-S M12 Cable
ZK-M12-5-5M-2-PUR-S M12 Cable
ZK-M12-8-2M-1-PUR-S M12 Cable
ZK-M12-8-2M-2-PUR-S M12 Cable
ZK-M12-8-5M-1-PUR-S M12 Cable
ZK-M12-8-5M-2-PUR-S M12 Cable

DIMENSIONS (IN MM)

AS5918 / AS5918...E/ENM24

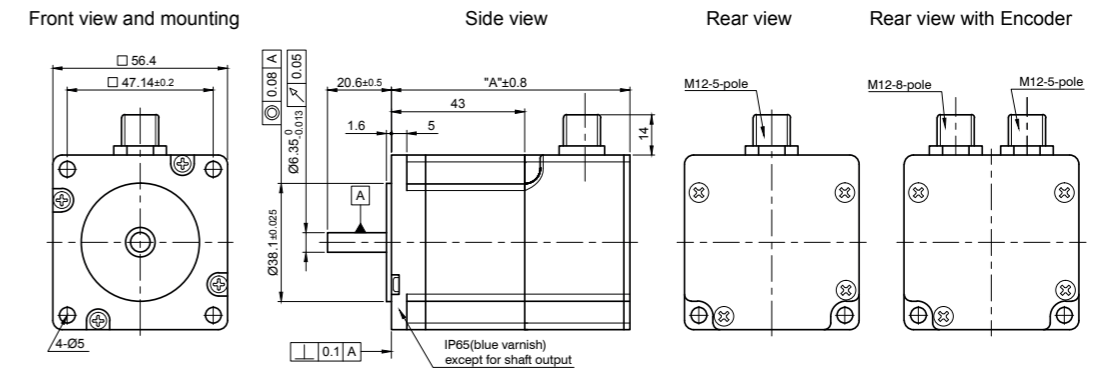

AS5918L...EB/ENM24B

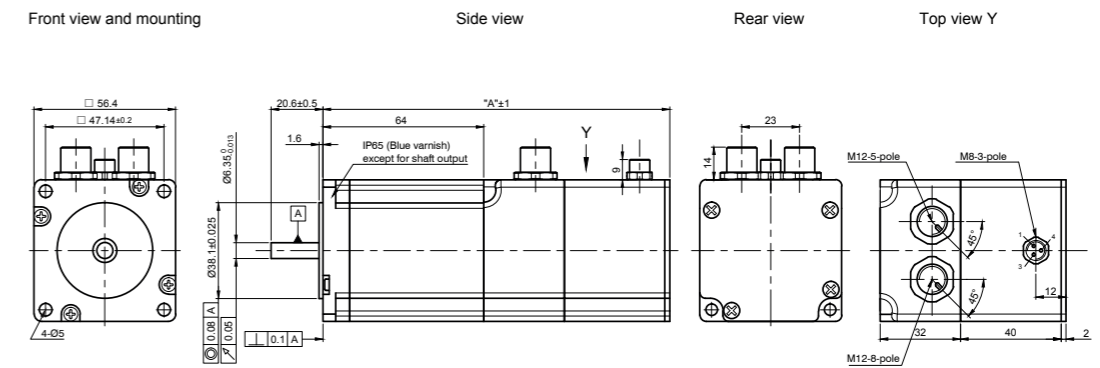

TORQUE CURVES

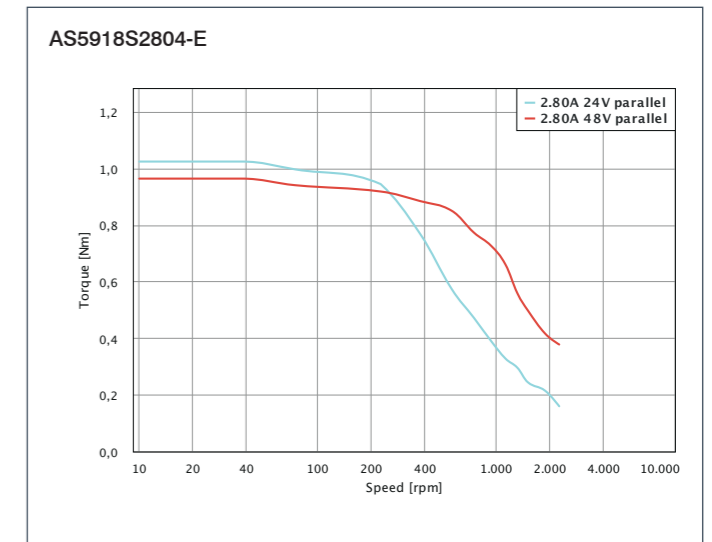
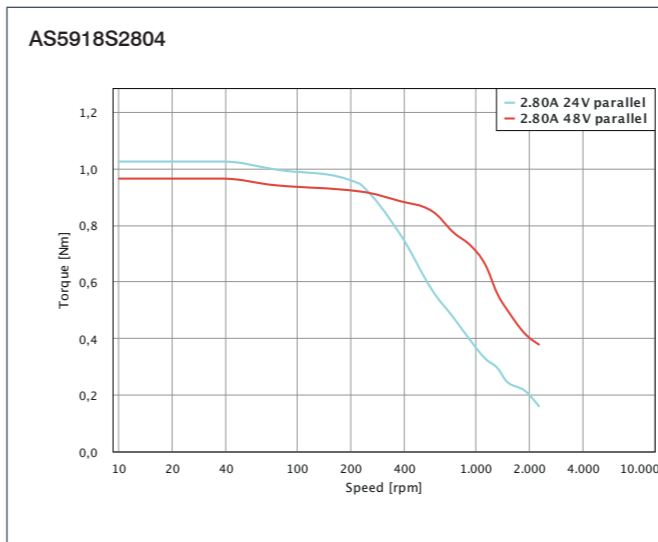

TORQUE CURVES

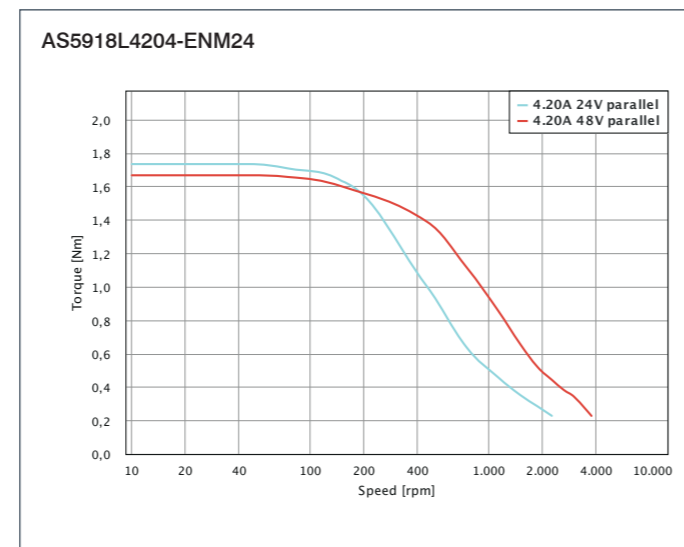
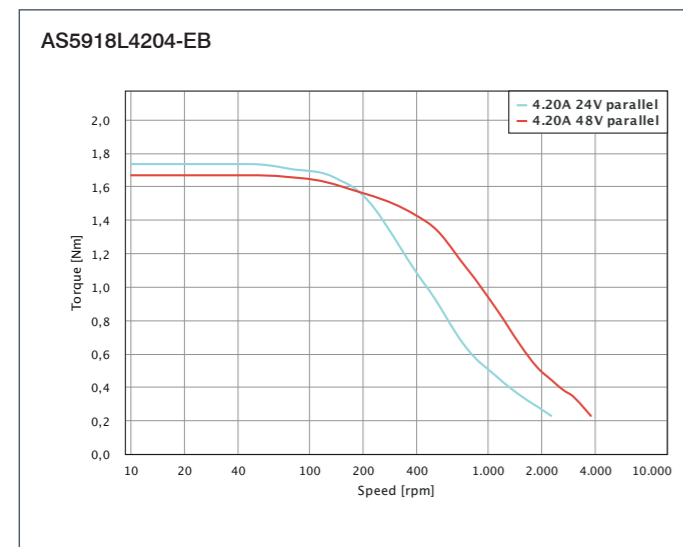
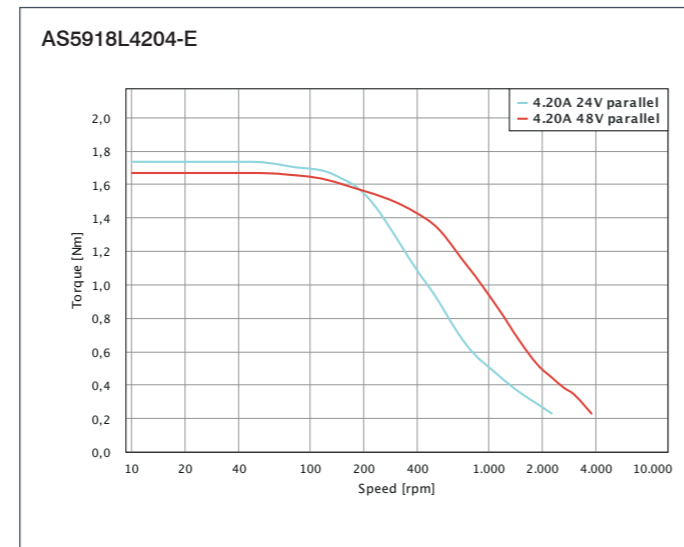
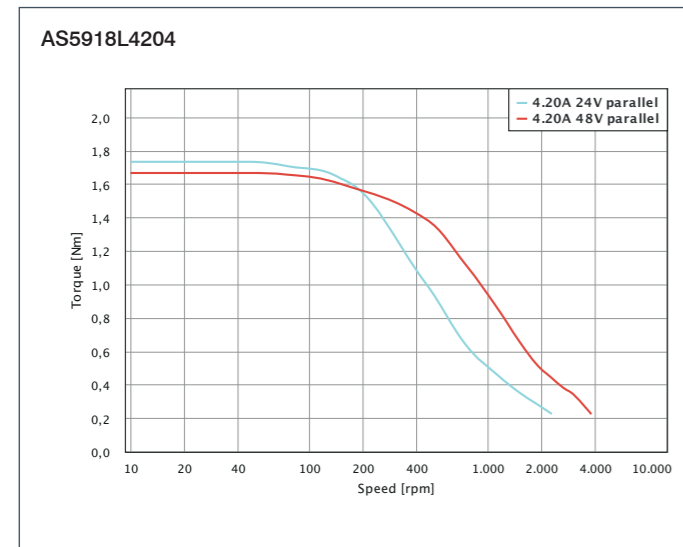
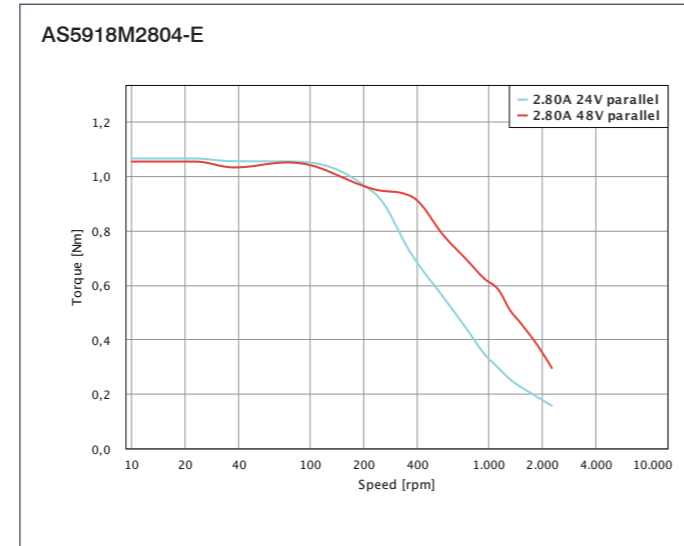
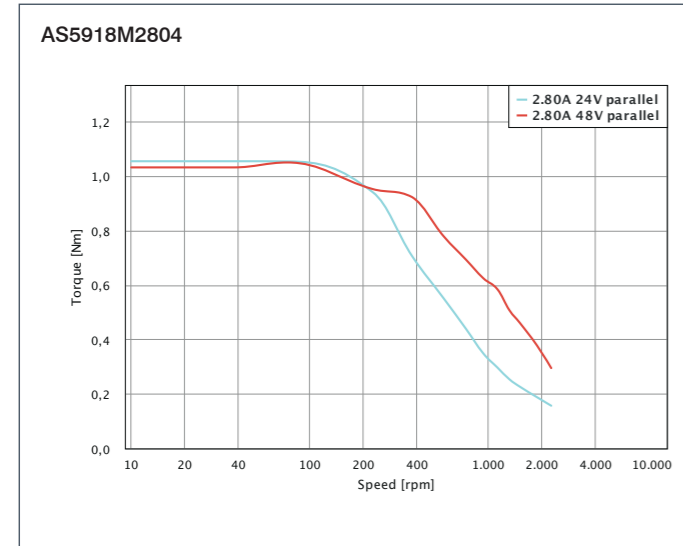

TORQUE CURVES

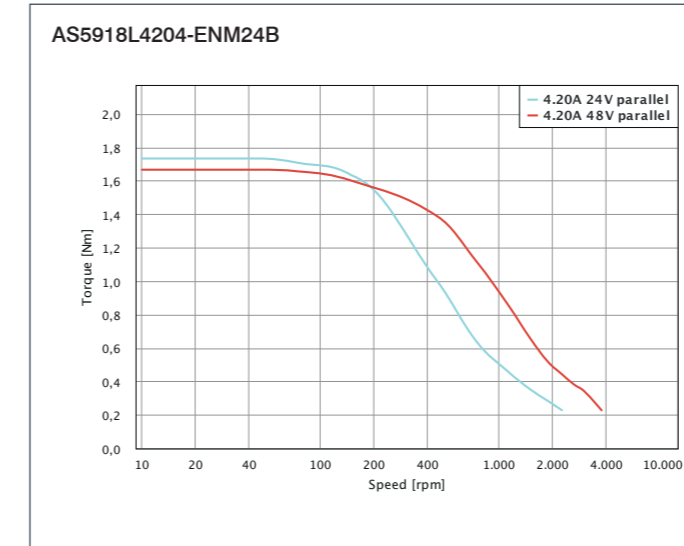



OPTIONS



DESCRIPTION

2-phase, high-torque stepper motor in size NEMA 34 (86 mm) and with a step angle (full step) of 1.8° in protection class IP65. This motor will work as a replacement for the standard motor ST8918 as they have the same flange size.

VERSIONS

Type	Current per Winding A/Winding	Holding Torque Ncm	Resistance per Winding Ohm	Inductance per Winding mH	Rotor Inertia gcm ²	Weight kg	Length „A“ mm	Encoder Type V	Brake Torque Nm
AS8918L9504-E24	9.5	933	0.26	2.7	300	4.35	148	24	
AS8918L9504-E24B	9.5	933	0.26	2.7	300	5	218	24	4

ORDER IDENTIFIER

AS8918L9504-
 E24 = with 24V Encoder
 E24B = with 24V Encoder and Brake

ACCESSORIES

ZK-TW-7-2M M16 (TW) Cable
ZK-M12-12-2M-1-PUR-S M12 Cable
ZK-M12-12-2M-2-PUR-S M12 Cable

DIMENSIONS (IN MM)

AS8918L9504-E24

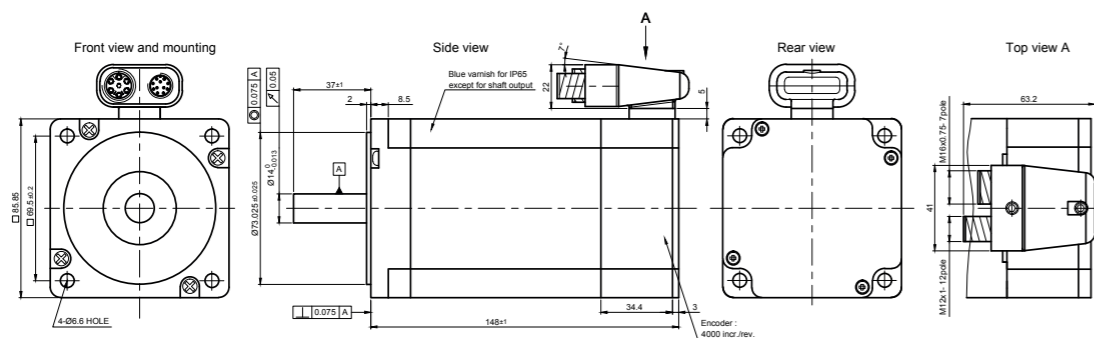

DIMENSIONS (IN MM)

AS8918L9504-E24B

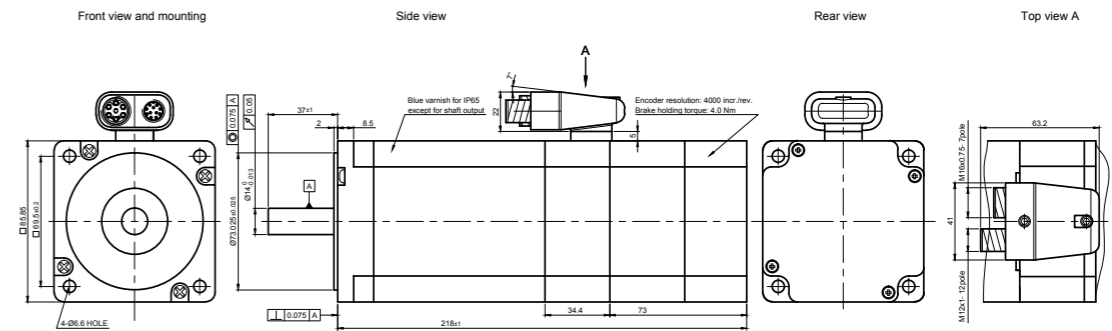

TORQUE CURVES

AS8918L9504-E24

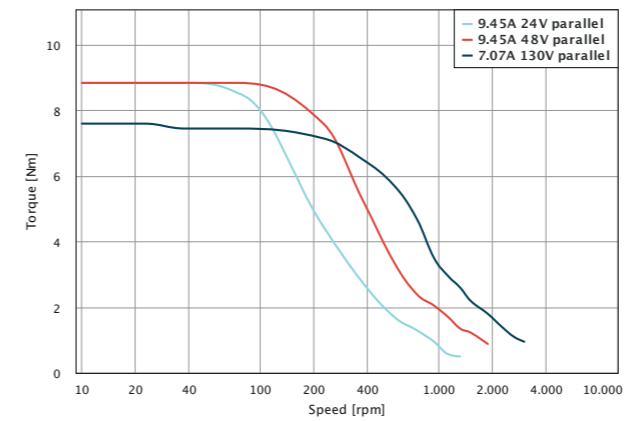

AS8918L9504-E24B

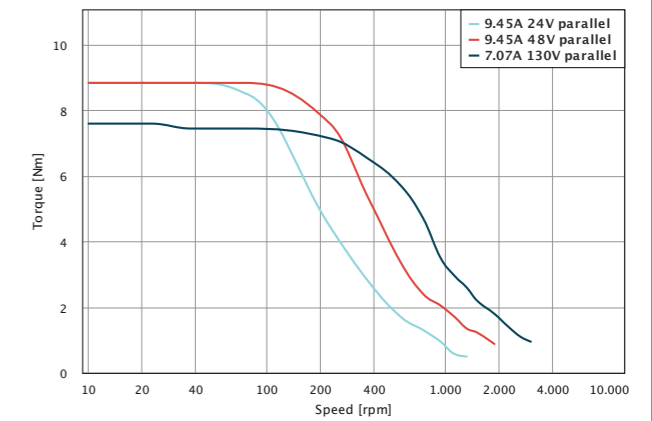



OPTIONS



DESCRIPTION

2-phase, high-torque stepper motor in size NEMA 34 (89 mm) and with a step angle (full step) of 1.8° in protection class IP65 (except for shaft outlet). This motor will work as a replacement for the standard motor ST8918 as they have the same flange size.

VERSIONS

Type	Current per Winding A/Winding	Holding Torque Ncm	Resistance per Winding Ohm	Inductance per Winding mH	Rotor Inertia gcm ²	Weight kg	Length „A“ mm	Encoder Type V
AP8918M6404	6.4	594	0.33	3	2700	3.4	118	
AP8918M6404-E	6.4	594	0.33	3	3000	3.5	118	5
AP8918L9504	9.5	933	0.26	2.7	3000	4.6	148	
AP8918L9504-E	9.5	933	0.26	2.7	3000	4.7	148	5

ORDER IDENTIFIER

AP8918M6404-
E = with Encoder

ACCESSORIES

- ZK-M12-5-2M-1-PUR-S M12 Cable
- ZK-M12-5-2M-2-PUR-S M12 Cable
- ZK-M12-5-5M-1-PUR-S M12 Cable
- ZK-M12-5-5M-2-PUR-S M12 Cable
- ZK-M12-8-2M-1-PUR-S M12 Cable
- ZK-M12-8-2M-2-PUR-S M12 Cable
- ZK-M12-8-5M-1-PUR-S M12 Cable
- ZK-M12-8-5M-2-PUR-S M12 Cable

DIMENSIONS (IN MM)

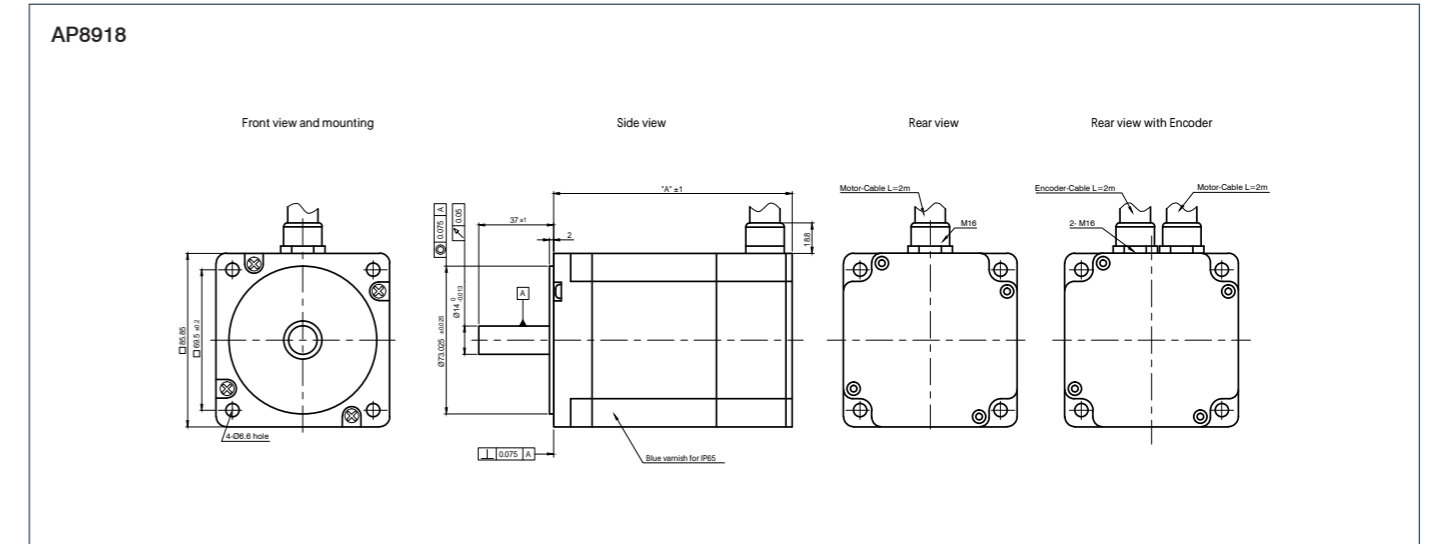

TORQUE CURVES

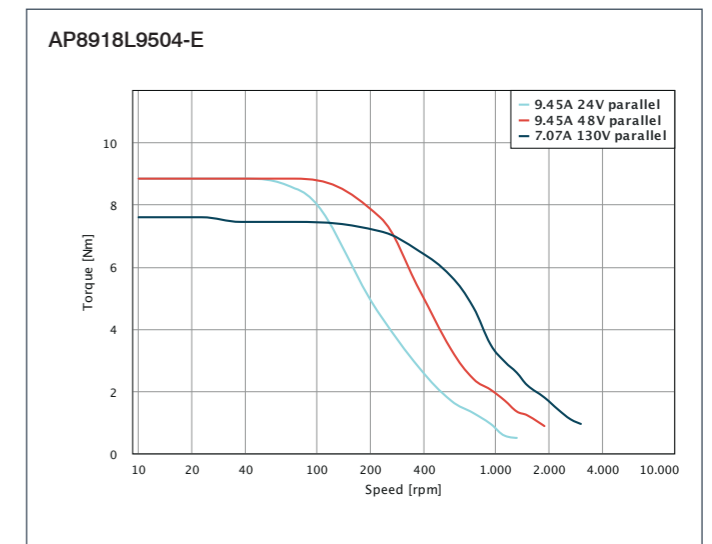
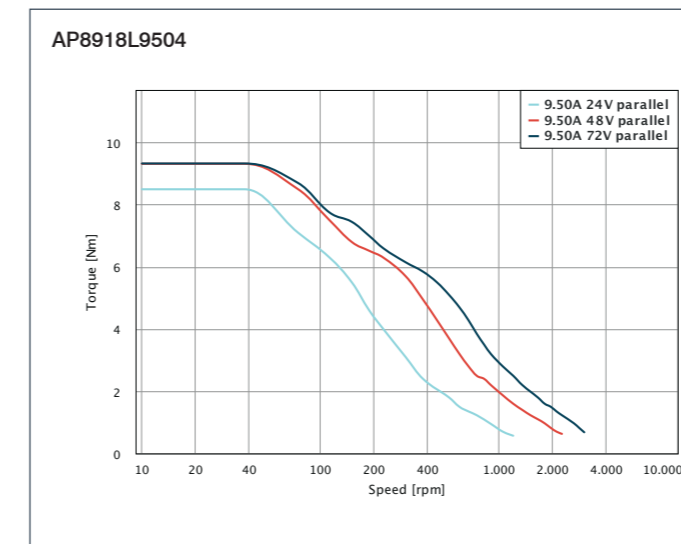
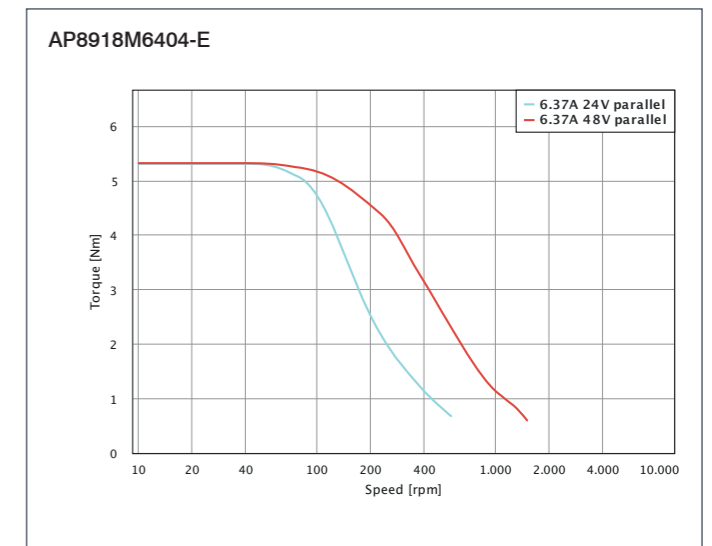
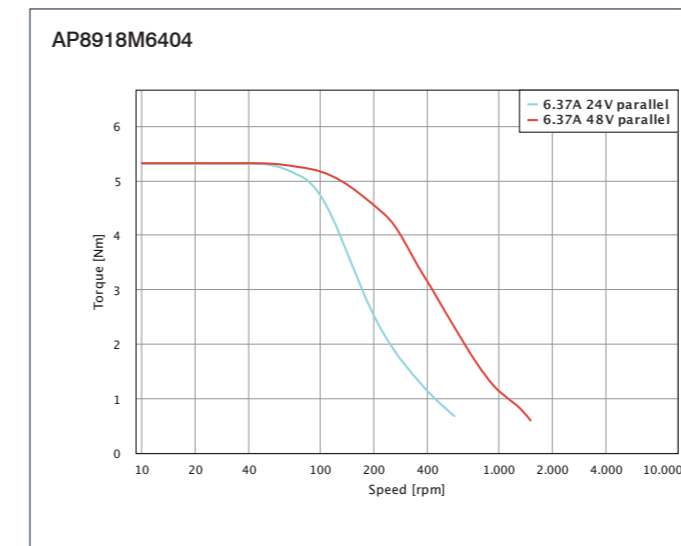

A series of horizontal dotted lines for taking notes, spanning the left side of the page.



ST4118

Stepper Motor with Hollow Shaft - NEMA 17



OPTION



VERSIONS

Type	Step Resolution ° (full step)	Current per Winding A/Winding	Holding Torque Ncm	Resistance per Winding Ohm	Inductance per Winding mH	Rotor Inertia gcm ²	Weight kg	Length „A“ mm
ST4118M1804-L	1.8	1.8	28	1.1	1.85	570	0.24	38

DIMENSIONS (IN MM)

ST4118

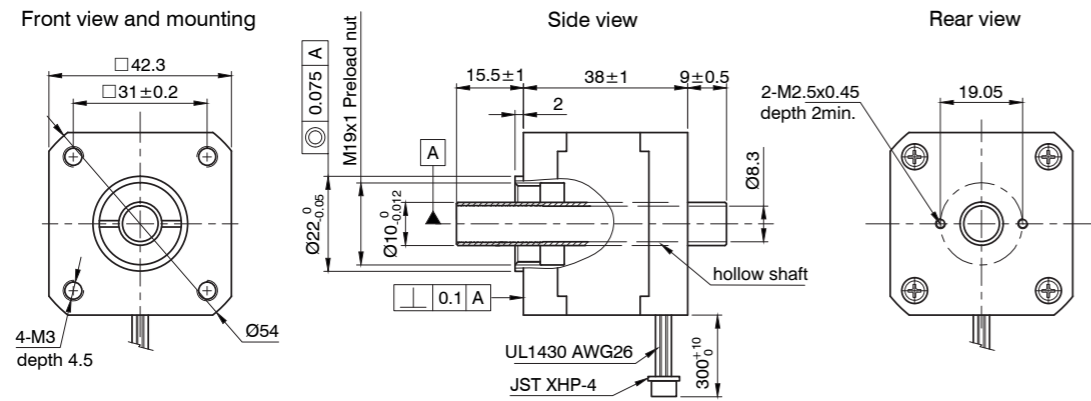

ST5918

Stepper Motor with Hollow Shaft - NEMA 23



OPTION



VERSIONS

Type	Step Resolution ° (full step)	Current per Winding A/Winding	Holding Torque Ncm	Resistance per Winding Ohm	Inductance per Winding mH	Rotor Inertia gcm ²	Weight kg	Length „A“ mm
ST5918S3008-L2	1.8	2.1	91.9	1.44	4.4	275	0.65	51

DIMENSIONS (IN MM)

ST5918

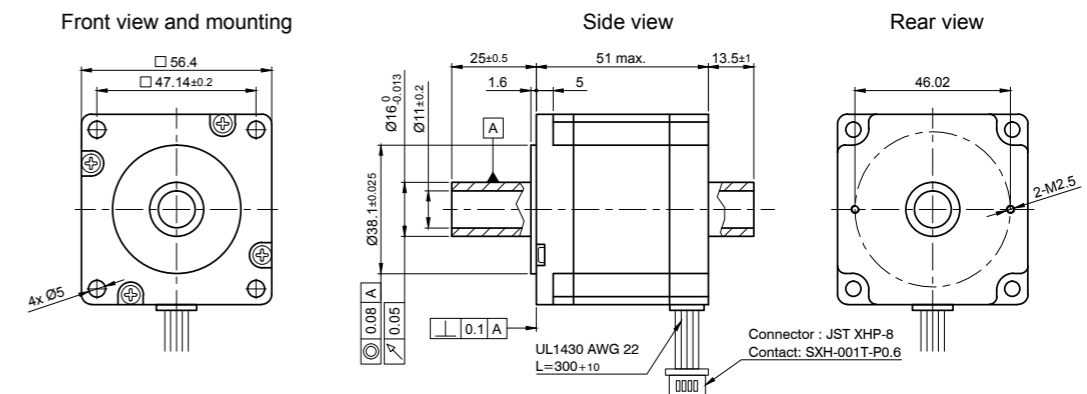

KENNLINIEN

ST5918S3008-L2

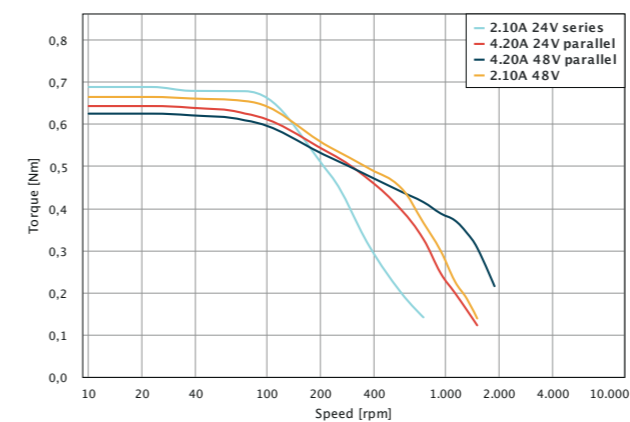

ADVANTAGES

- Significantly higher efficiency and power density than induction motors (with approx. 35% less volume and weight at the same output)
- Very high expected service life and smooth running in brushless technology with precision ball race
- Thanks to the linear torque curve, an exceptionally large speed range at full motor output and therefore improved matching to the required load conditions
- Reduced electrical interference emission along with excellent thermal properties
- Mechanically interchangeable with stepper motors, and hence less construction expense and greater parts variety

Electronically commutated 3-phase brushless motors (EC motors) are particularly well suited for applications that need smooth running and long service life. The high-energy permanent magnets allow high acceleration and speeds of up to 14,000 rpm with exceptional efficiency. The rotor position is reported electronically using three hall sensors offset by 60 and 120°. Optional encoders with up to 2000 CPR allow high-resolution position controlling.

PROPERTIES

TORQUE/CURRENT CHARACTERISTICS

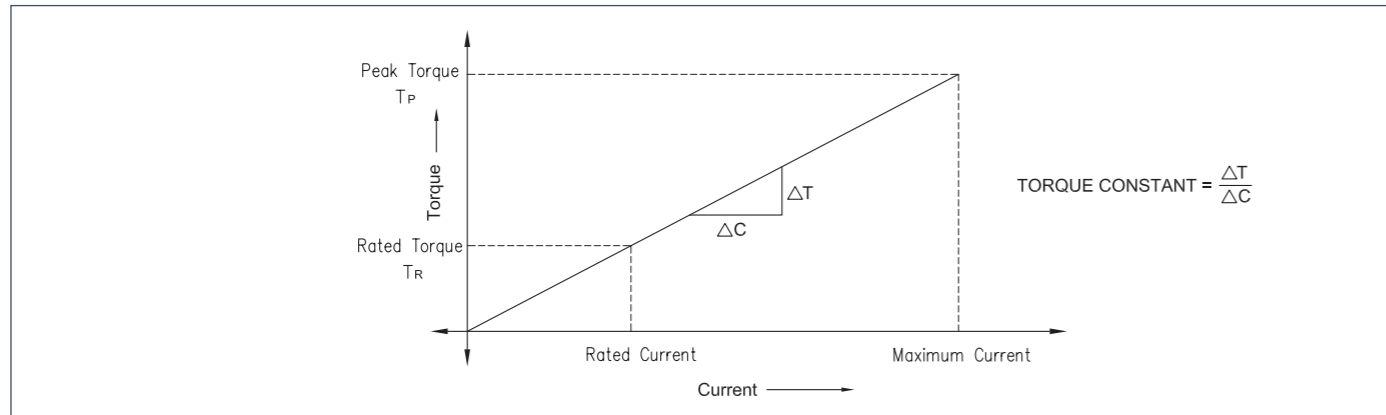

TORQUE/SPEED CHARACTERISTICS

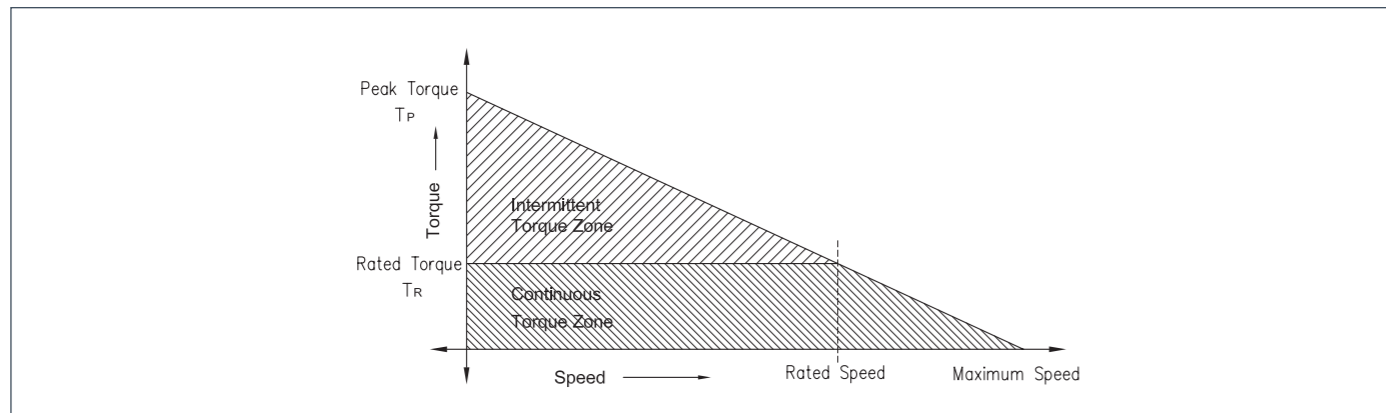

OPTION



VERSIONS

Type	Nominal Output W	Nominal Torque Ncm	Nominal Current A	Nominal Voltage V	Nominal Speed rpm	Torque Constant Ncm/A	Rotor Inertia gcm ²	Weight kg	Length „A“ mm
DB22M01	3.8	0.8	0.265	24	4800	3.02	0.66	0.07	45
DB22L01	7.7	2.2	0.62	24	3500	3.55	1.32	0.12	68

DIMENSIONS (IN MM)

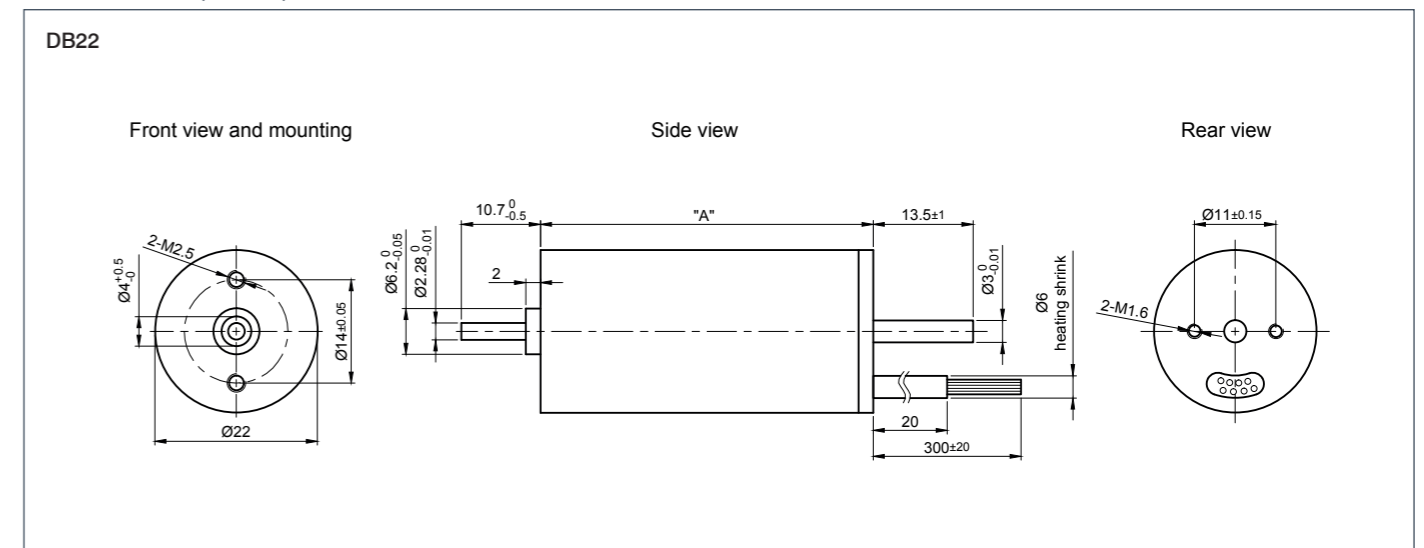

DB28

Brushless DC Motor



OPTION



VERSIONS

Type	Nominal Output W	Nominal Torque Ncm	Nominal Current A	Nominal Voltage V	Nominal Speed rpm	Torque Constant Ncm/A	Rotor Inertia gcm ²	Weight kg	Length „A“ mm
DB28S01	6	0.7	0.51	15	8000	1.37	1.23	0.06	26
DB28M01	14	1.4	0.88	24	10000	1.6	2.12	0.082	38
DB28L01	16	5	1	24	3700	5	5.98	0.28	77

DIMENSIONS (IN MM)

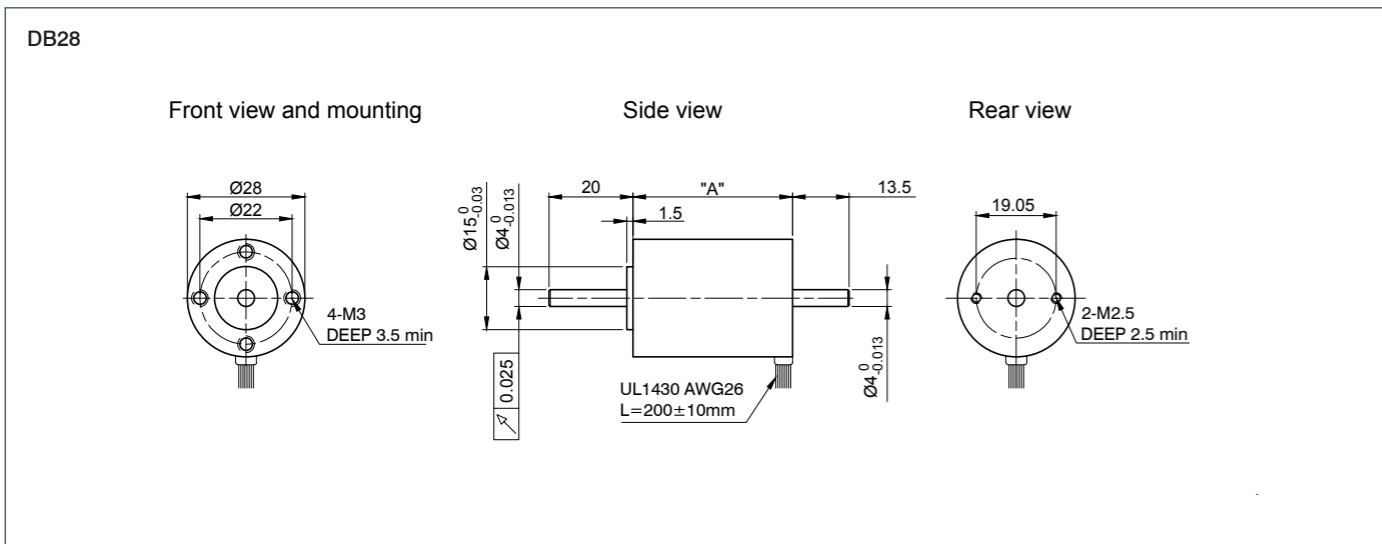

DB33

Brushless DC Motor



OPTION



VERSIONS

Type	Nominal Output W	Nominal Torque Ncm	Nominal Current A	Nominal Voltage V	Nominal Speed rpm	Torque Constant Ncm/A	Rotor Inertia gcm ²	Weight kg	Length „A“ mm
DB33S01	7	2.2	0.56	24	3000	4.6	2.94	0.115	38

DIMENSIONS (IN MM)

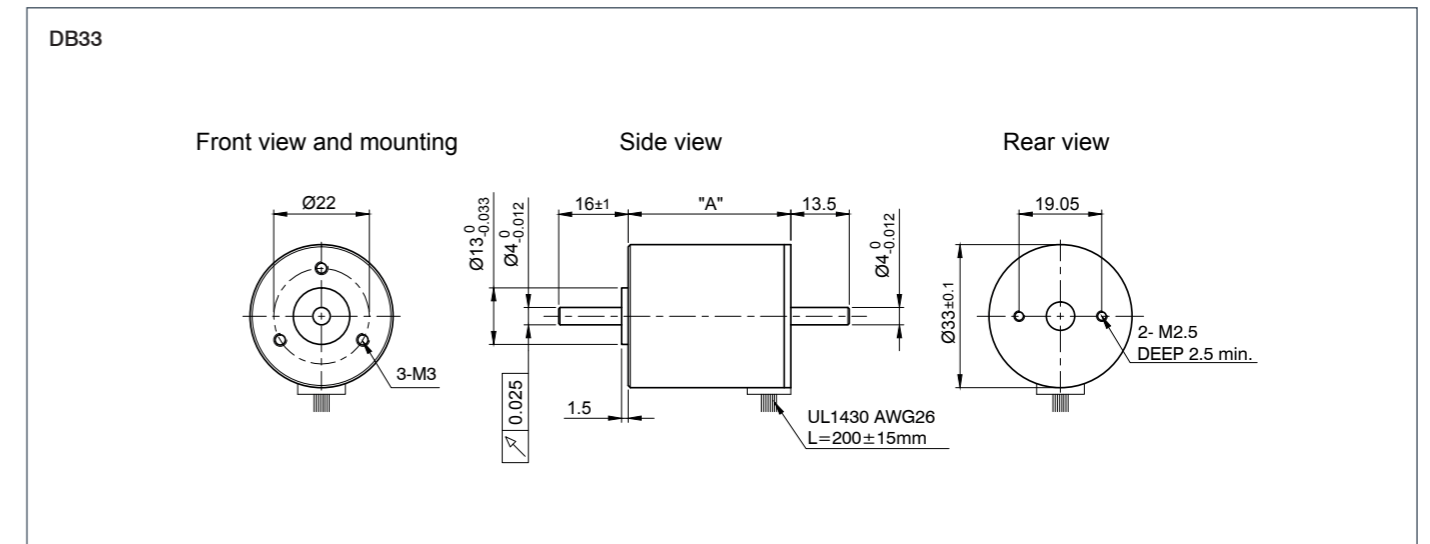

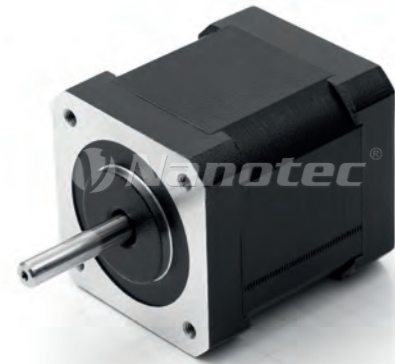

OPTION



VERSIONS

Type	Nominal Output W	Nominal Torque Ncm	Nominal Current A	Nominal Voltage V	Nominal Speed rpm	Torque Constant Ncm/A	Rotor Inertia gcm ²	Weight kg	Length „A“ mm
DB42S01	40	5	0.88	48	6000	5.7	24	0.25	41
DB42S02	40	5	3.57	17	8000	1.4	24	0.25	41
DB42S03	26	6.25	1.79	24	4000	3.5	24	0.3	41
DB42M01	70	11	2.12	48	6000	5.2	48	0.45	61
DB42M02	70	7	1.63	48	8500	4.3	48	0.45	61
DB42M03	52.5	12.5	3.47	24	4000	3.6	48	0.45	61
DB42L01	77.5	18	5.14	24	4000	3.6	72	0.65	81
DB42C01	160	25	4.63	48	6000	5.4	96	0.75	100
DB42C02	160	10	3.57	48	14000	2.8	96	0.75	100
DB42C03	105	25	6.65	24	4000	3.76	96	0.75	100

ACCESSORIES



ZD-D28	Damper
ZD-D40	Damper

DIMENSIONS (IN MM)

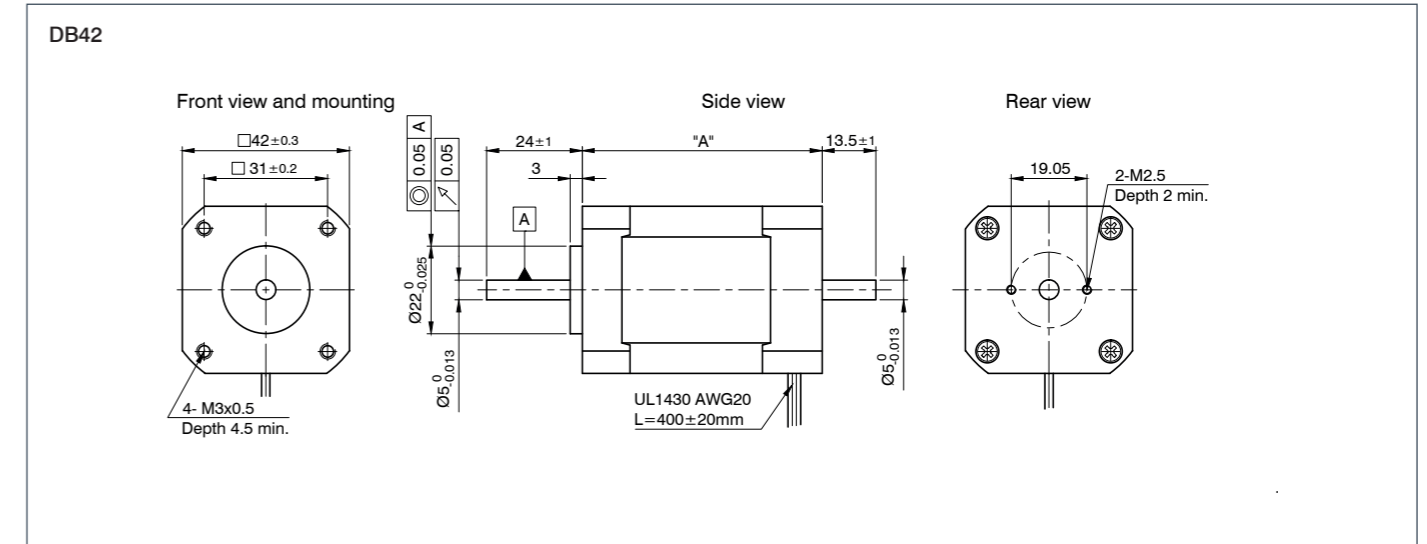

DB57

Brushless DC Motor



OPTION



VERSIONS

Type	Nominal Output W	Nominal Torque Ncm	Nominal Current A	Nominal Voltage V	Nominal Speed rpm	Torque Constant Ncm/A	Rotor Inertia gcm ²	Weight kg	Length „A“ mm
DB57S01	50	19	3.58	24	2700	5.3	200	0.6	50.8
DB57L01	75	28	4.67	24	2740	6	330	1.1	76.2
DB57C01	110	37	6.5	24	2800	6.3	500	1.5	101.6

ACCESSORIES



ZD-D56 Damper

DIMENSIONS (IN MM)

DB57

Front view and mounting

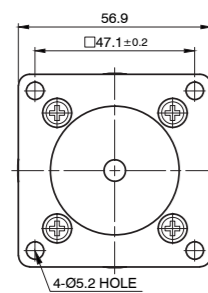

Side view

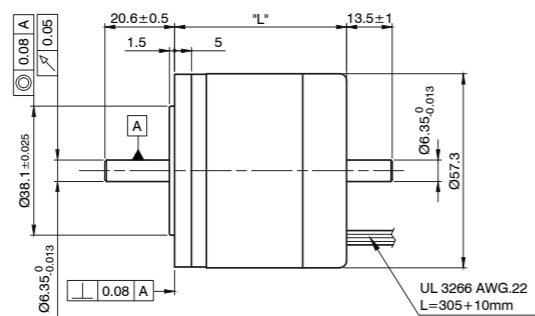

Rear view

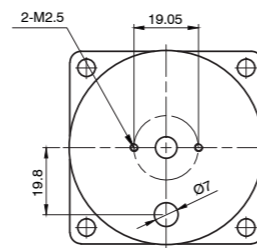

DB59

Brushless DC Motor



OPTION



VERSIONS

Type	Nominal Output W	Nominal Torque Ncm	Nominal Current A	Nominal Voltage V	Nominal Speed rpm	Torque Constant Ncm/A	Rotor Inertia gcm ²	Weight kg	Length „A“ mm
DB59S024035-A	84	23	5	24	3500	4.5	75	0.52	54
DB59M024035-A	135	37	8	24	3500	4.6	105	0.65	69
DB59L024035-A	172	47	9.4	24	3500	5	119	0.72	74
DB59C024035-A	220	60	13.6	24	3500	4.4	173	0.95	94

ACCESSORIES



ZD-DF56 Damper

DIMENSIONS (IN MM)

DB59

Front view and mounting

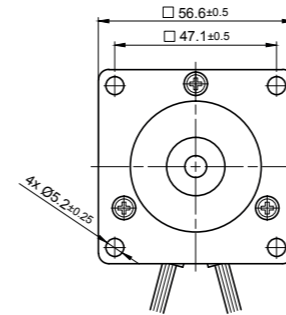

Side view

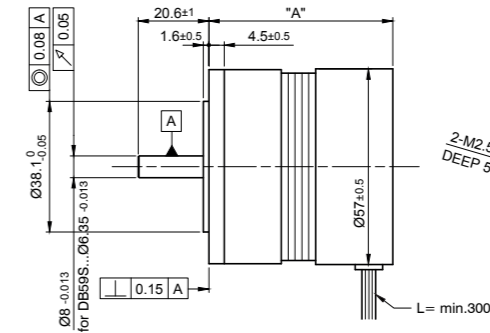

Rear view

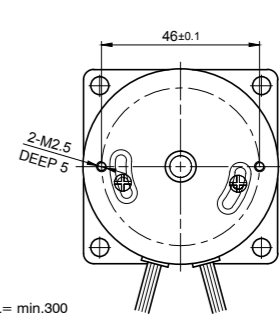



OPTION



VERSIONS

Type	Nominal Output W	Nominal Torque Ncm	Nominal Current A	Nominal Voltage V	Nominal Speed rpm	Torque Constant Ncm/A	Rotor Inertia gcm ²	Weight kg	Length „A“ mm
DB87S01-S	250	70	6.25	48	3000	11.2	800	1.85	86
DB87M01-S	440	140	10.77	48	3000	13	1600	2.6	113
DB87L01-S	750	210	17.95	48	3000	11.7	2400	4	140

ACCESSORIES



ZD-D56 Damper

DIMENSIONS (IN MM)

DB87

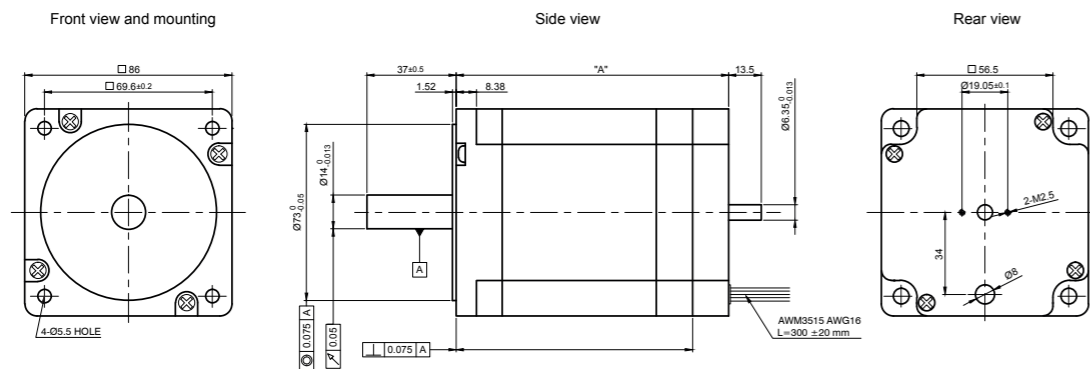

Lined area for notes.

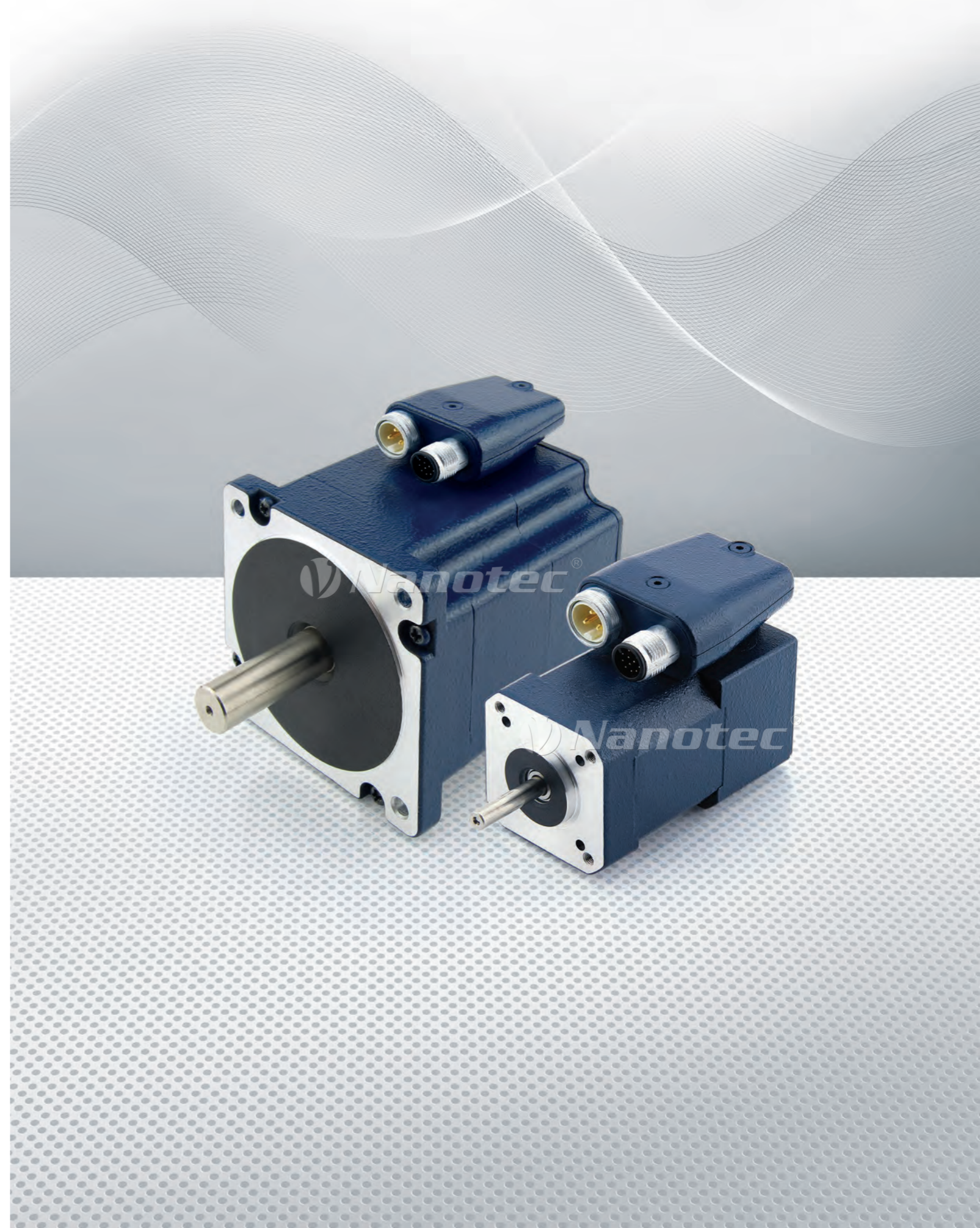



OPTION



DESCRIPTION

Due to its high-energy permanent magnets, the 3-phase BLDC motor ASB42 is ideally suited for applications where smooth running and a long service life are required. The housing of this motor with protection class IP 65 (except for shaft outlet) is sealed against humidity and dust. The ASB42 features M16 and M12 connectors for power and the rotary encoder.

Different motor versions offer torques ranging from 0.5 to 0.25 Nm and speeds ranging from 4000 to 14,000 rpm. The entire range of ASB BLDC motors include magnetic encoders which ensure precise positioning, even in challenging industrial environments.

VERSIONS

Type	Nominal Output W	Nominal Torque Ncm	Nominal Current A	Nominal Voltage V	Nominal Speed rpm	Torque Constant Ncm/A	Rotor Inertia gcm ²	Weight kg	Length „A“ mm
ASB42C048060-ENM	160	25	4.63	48	6000	5.4	96	0.75	121

ORDER IDENTIFIER

ASB42C048060-ENM

ACCESSORIES

- ZK-M12-12-2M-1-PUR-S M12 Cable
- ZK-M12-12-2M-2-PUR-S M12 Cable
- ZK-M12-12-5M-1-PUR-S M12 Cable
- ZK-M12-12-5M-2-PUR-S M12 Cable
- ZK-TW-4-2M M16 (TW) Cable

DIMENSIONS (IN MM)

ASB42C048060-ENM

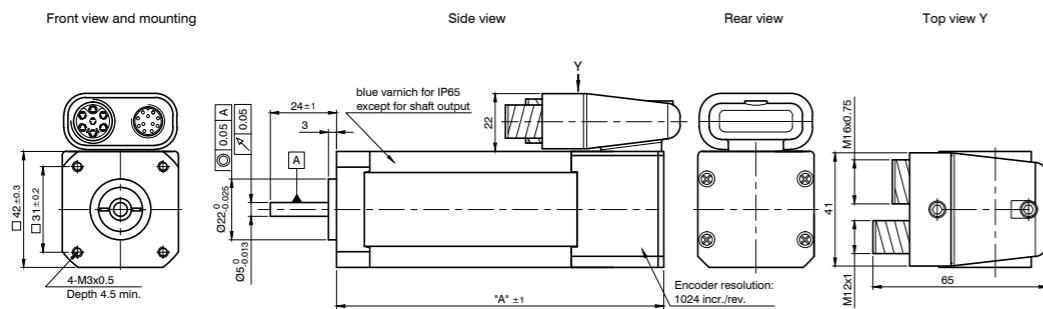

OPTION



DESCRIPTION

The brushless DC motor ASB87 was developed especially for rugged environments. The housing of this motor with protection class IP 65 (except for shaft outlet) is sealed against humidity and dust. Complete IP rating is available for OEM customers upon request.

The ASB87 features a built-in 1024 CPR magnetic encoder and doesn't require additional hall sensors. The reference signal is synchronous to the hall phase for even more exact positioning.

VERSIONS

Type	Nominal Output W	Nominal Torque Ncm	Nominal Current A	Nominal Voltage V	Nominal Speed rpm	Torque Constant Ncm/A	Rotor Inertia gcm ²	Weight kg	Length „A“ mm
ASB87S048030-ENM	250	70	6.25	48	3000	11.2	800	1.85	91.9

ORDER IDENTIFIER

ASB87S048030-ENM

ACCESSORIES

- ZK-TW-7-2M M16 (TW) Cable

DIMENSIONS (IN MM)

ASB87S048030-ENM

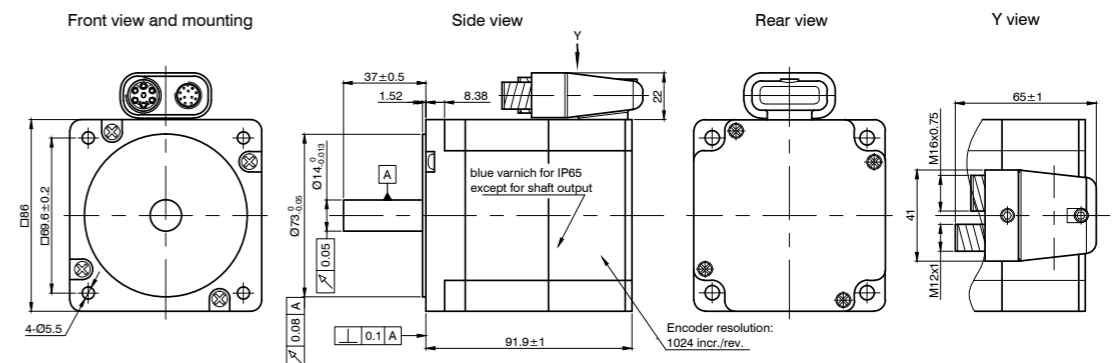

A series of horizontal dotted lines for taking notes, spanning the left side of the page.



WHAT LINEAR DRIVES ARE AVAILABLE?

1. Linear actuator (non-captive)

A threaded nut is worked into the motor's hollow shaft. It converts the rotary motion of the motor into linear motion for a screw. The screw has to be prevented from rotating in order to achieve linear motion.

2. Linear actuator with linear slide (captive)

The linear actuator's screw is coupled with a rod, thereby securing it from being twisted out of position.

3. Linear positioning drive

The thread is attached to the motor shaft. A nut on the shaft carries out the linear motion.

NANOTEC LINEAR DRIVES

- Are constructed to be simple and flexible
- Offer a high and reproducible resolution (<math><1 \mu\text{m}</math>) and fast feeding (>300 mm/sec.)
- Are mechanically exchangeable with standard motors and allow consistent construction platforms
- Are designed to be energy-saving
- Are partially self-locking and thus can be operated without a brake
- Are low-friction and low-wear due to the PEEK nuts being used
- Are designed in terms of performance to be an affordable and flexible alternative to hydraulic and pneumatic cylinders

SELECTING A SUITABLE DESIGN

- Which stroke is necessary?
- Should an encoder or a brake be connected?
- Should a freely movable end move the load or is a fixed screw necessary?
- Are there limits in the application design?

SELECTING THE MOTOR OUTPUT

In order to find a suitable linear drive, you need information about

- The load being moved
- The movement direction (vertical or horizontal)
- The required feed speed
- The acceleration torque
- The required torque
- The stroke
- The positioning and repeatability
- The maximum permitted screw clearance

ESTIMATED SERVICE LIFE

The force and power rating specified in the data sheets is based on a duty cycle of 10% to 20% and has to be reduced accordingly for higher values.

PERFORMANCE CALCULATION FOR SELECTING LINEAR ACTUATORS

The achievable resolutions, feed speeds and forces are calculated based on the screw pitch (p in mm), torque (M_d in Nm) and efficiency for a stepper motor as follows:

Resolution in mm/step	Formula: $p/(360^\circ/\text{step angle})$ Example: $1 \text{ mm}/(360^\circ/0.9^\circ) = 0.0025 \text{ mm/step}$
Feed speed	Formula: Speed x screw pitch Example: $900 \text{ rpm} \times 2 \text{ mm} = 30 \text{ mm/s}$
Force in N	Formula: $M_{d\text{Mot}} \times 2\pi \times \text{efficiency}/p$ Example: Motor L4118S, approx. 0.22 Nm at 48 V, 900 rpm, with a screw pitch of 2 mm $F = 0.22 \text{ Nm} \times 6.28 \times 0.43/0.002 \text{ m} = 297 \text{ N}$
Efficiency	The efficiency of a lead screw drive is approx. 0.3 – 0.6, depending on diameter, pitch, nut material and lubrication.
Acceleration torque	Formula: Linear: $F = m \cdot a$ ($a = v_e - v_a/t$) v_e = end speed, v_a = starting speed Formula: Linear: $F = m \cdot g \cdot \mu$ The frictional force F (N) is determined primarily by the mass = m (weight, kg) and the coefficient of friction = μ .

The correct thread pitch, motor size and step angle have a substantial influence on the precision, the axial forces and the speed of the linear drive. A curve comparison can enable a specific model to be selected if framework data is known.

CURVE COMPARISON FOR SELECTING A LINEAR ACTUATOR

The curve comparison makes the differences obvious that need to be taken into account during the selection process. Both graphics show the curves for a performance comparison using the L4118 linear actuator model with T5x5 and T6x2 threading as an example.

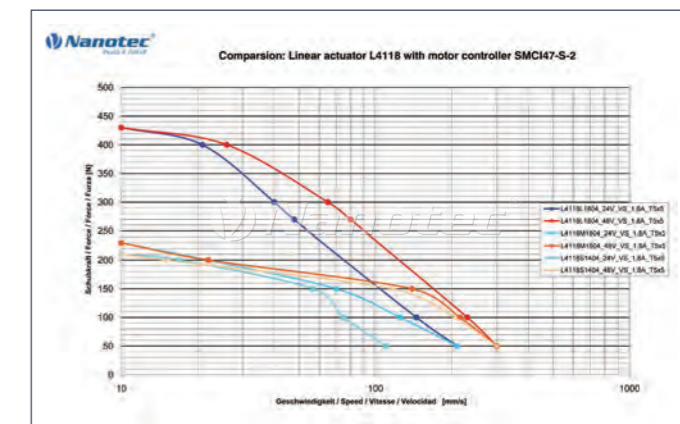
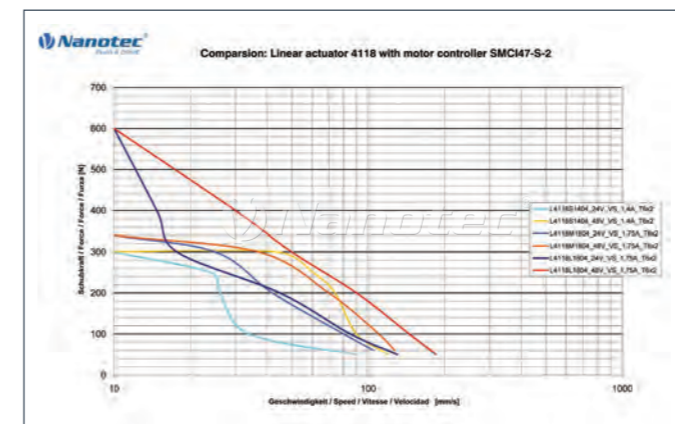

CAUTION

Ensure that no radial forces are being applied to the screw and that the screw is running concentrically relative to the motor shaft. The screw has to be prevented from rotating in order to achieve linear motion.

ACCESSORIES

Suitable screws are available for each linear actuator under Accessories.

LUBRICATION

The PEEK material used for the thread nut and the nut is self-lubricating. However, we recommend lubricating these parts once during setup and installation for a longer service life. Suitable substances are dry lubricants (especially in the case of slower speeds and short duty cycles) or roller bearing greases such as Klüber Microlube GBUY131. You can also order a suitable grease directly from Nanotec under the order identifier "Nanolube".

The lubrication intervals, lubricant suitability and the resulting service life always depend on the application and the ambient conditions, and therefore need to be tested in the application.



OPTION



VERSIONS

Type	Force N	Resolution $\mu\text{m}/\text{step}$	Pitch of screw mm	Stroke „A“ mm	Current per Winding A/Winding	Resistance per Winding Ohm	Step Resolution ° (full step)	Weight kg	Length „A“ mm
LPV2515S0104-TR3,5X1	5	41.7	1	12	0.1	53	15	0.04	16
LP2515S0104-TR3,5X1	10	41.7	1	40	0.1	53	15	0.036	16.5
LP3575S0504-TR3.5X1	55	25.4	1.22	75	0.46	11	7.5	0.086	17.5

ACCESSORIES

Nanolube Lubricant

CAUTION

The force and power ratings specified in the datasheets are based on a power-up time of approx. 10% - 20% and must be reduced accordingly for higher values. Moving against fixed end stops should be avoided.

DIMENSIONS (IN MM)

LP2515S0104

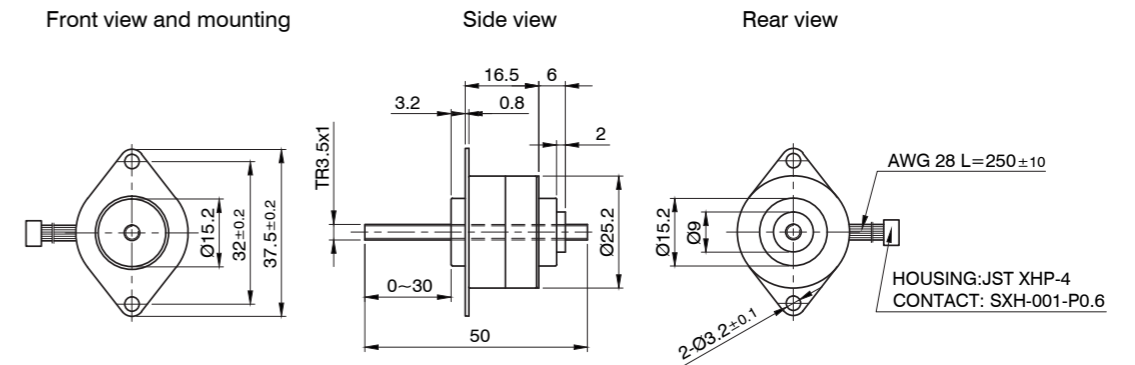

LP3575S0504

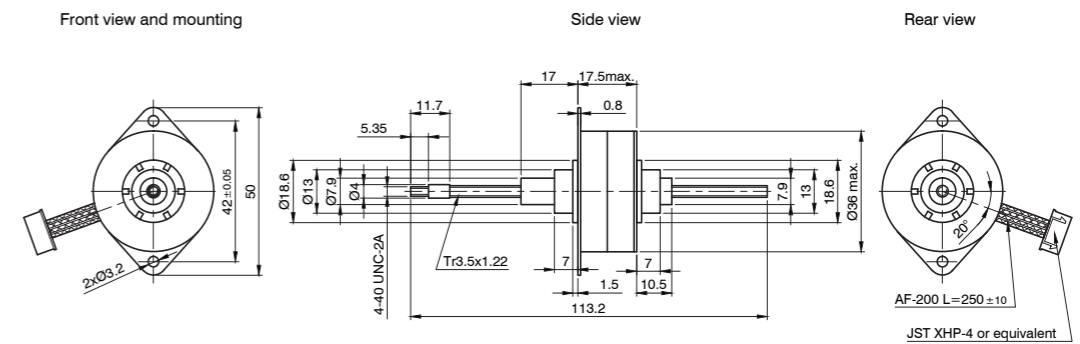

LPV2515S0104

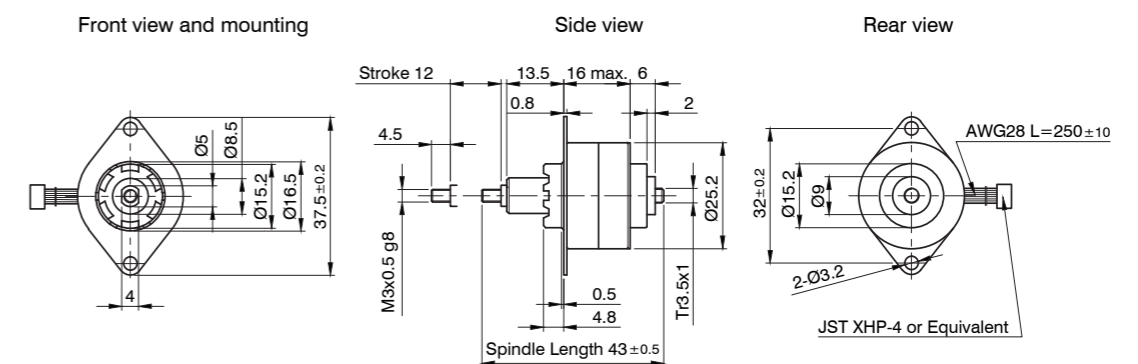



OPTION



VERSIONS

Type	Force N	Feed mm/s	Resolution $\mu\text{m}/\text{step}$	Pitch of screw mm	Thread Length mm	Current per Winding A/Winding	Resistance per Winding Ohm	Inductance per Winding mH	Weight kg	Length „A“ mm
LSP0818M0104-M2X0,25	0.8	20	14	0.25	11	0.12	13	1.5	0.003	7.8
LSP1018M0204-M2X0,25	4	20	14	0.25	13.5	0.22	15	3	0.0043	10
LSP1518M0104-M2X0,4	3	20	20	0.4	18	0.071	170	28	0.013	11
LSP2575M0506-M2X0,4	10	15	8	0.4	30	0.5	10	2	0.0312	15
LSP3575M0206-M3X0,5	40	10	10	0.5	30	0.22	60	45	0.094	22
LSP4275M0206-M3X0,5	50	10	10	0.5	30	0.18	70	72	0.134	22

ACCESSORIES

Nanolube Lubricant



CAUTION



The force and power ratings specified in the datasheets are based on a power-up time of approx. 10% - 20% and must be reduced accordingly for higher values. Moving against fixed end stops should be avoided.

DIMENSIONS (IN MM)

LSP1518M0104

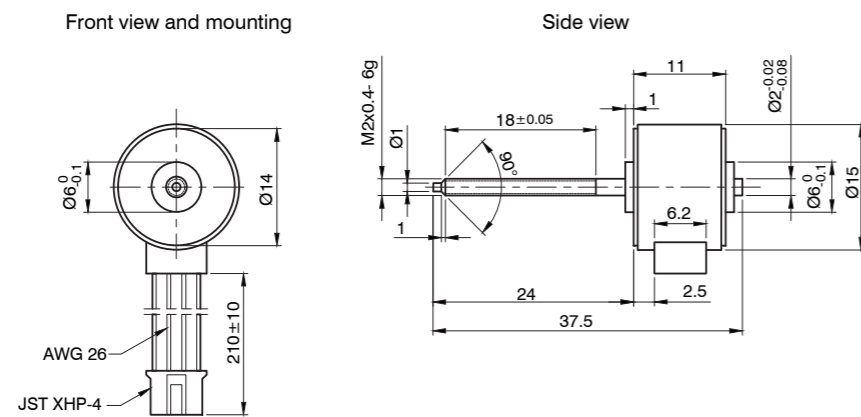

DIMENSIONS (IN MM)

LSP2575M0506

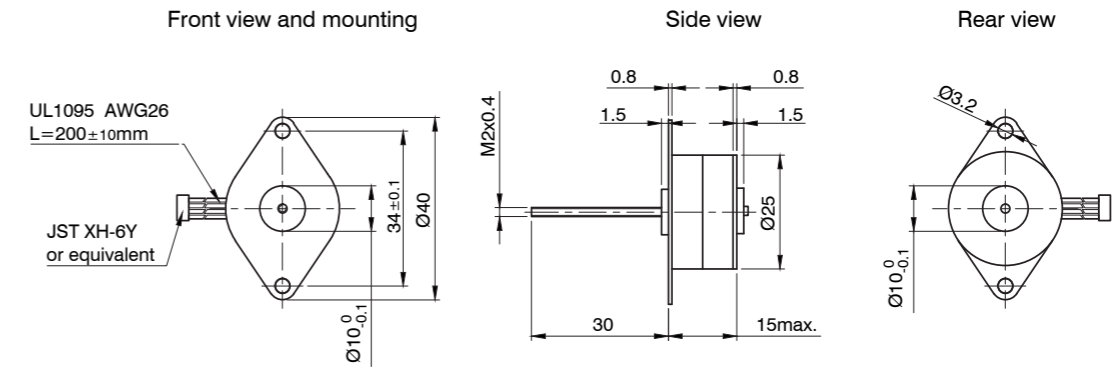

LSP3575M0206

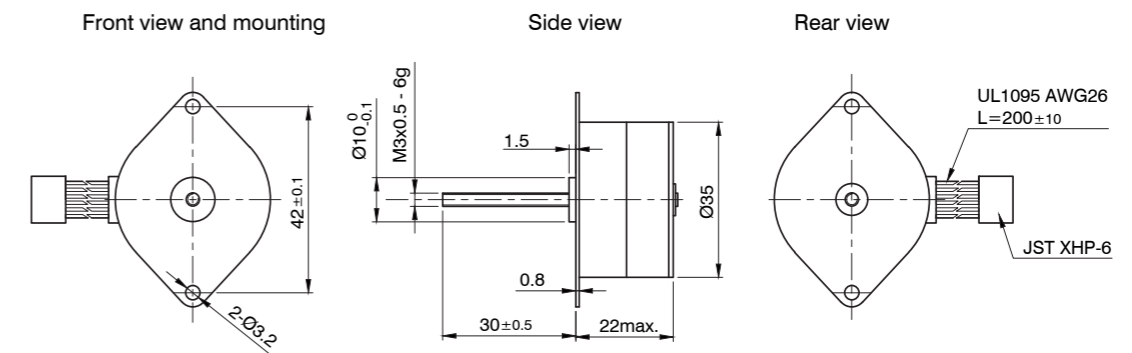

LSP4275M0206

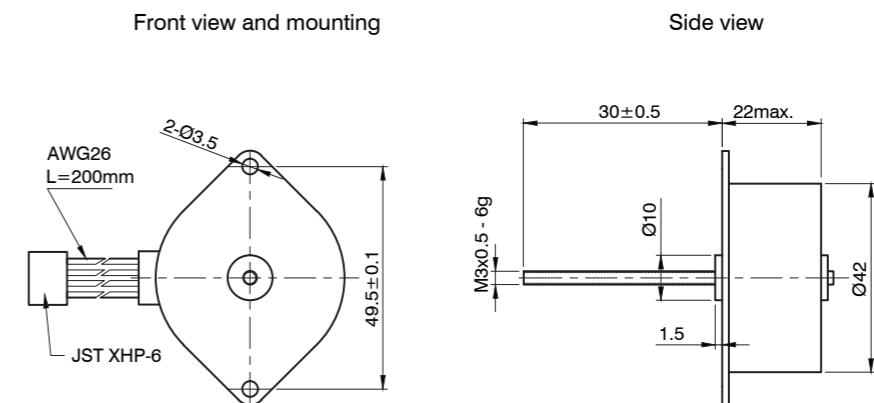



OPTION



VERSIONS

Type	Force N	Feed mm/s	Resolution $\mu\text{m}/\text{step}$	Current per Winding A/Winding	Resistance per Winding Ohm	Weight kg	Length „A“ mm
LS2018S0604-T3.5-A	30	40	5	0.6	6.5	0.06	33

ORDER IDENTIFIER

LS2018S0604-T3,5-
150 = 150 mm Thread Length
75 = 75 mm Thread Length

ACCESSORIES

LSNUT_T3.5x1 Threaded Nut
Nanolube Lubricant

CAUTION

The force and power ratings specified in the datasheets are based on a power-up time of approx. 10% - 20% and must be reduced accordingly for higher values. Moving against fixed end stops should be avoided.

DIMENSIONS (IN MM)

LS2018

Front view and mounting

Side view

Rear view

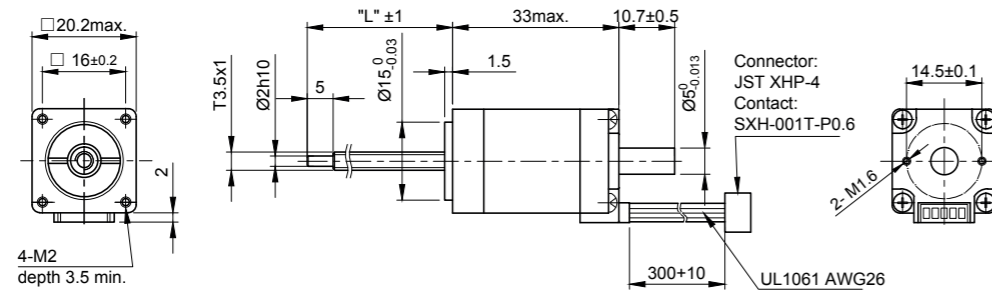

OPTION



VERSIONS

Type	Force N	Feed mm/s	Pitch of screw mm	Resolution $\mu\text{m}/\text{step}$	Current per Winding A/Winding	Resistance per Winding Ohm	Inductance per Winding mH	Weight kg	Bushing Length „L“ mm	Length „A“ mm
L2818S0604-T5X5	30	100	5	25	0.67	5.6	4	0.11	20	31.5
L2818L0604-T5X5	60	140	5	25	0.67	9.2	7.2	0.19	20	50.5

ORDER IDENTIFIER

L2818S0604-T5X5

ACCESSORIES

ZST5-5-200-1 Threaded Screw
ZST5-5-300-1 Threaded Screw
ZST5-5-1050 Threaded Screw
Nanolube Lubricant

CAUTION

The force and power ratings specified in the datasheets are based on a power-up time of approx. 10% - 20% and must be reduced accordingly for higher values. Moving against fixed end stops should be avoided.

DIMENSIONS (IN MM)

L2818

Front view and mounting

Side view

Rear view

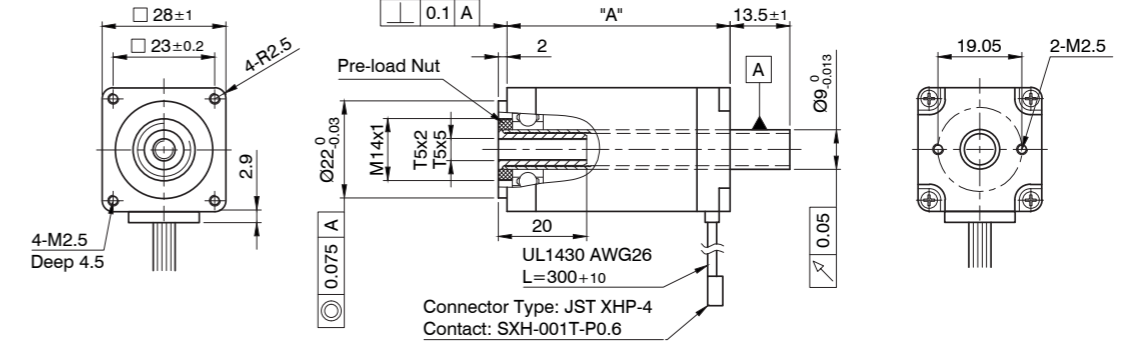



OPTION



VERSIONS

Type	Force N	Feed mm/s	Pitch of screw mm	Resolution $\mu\text{m}/\text{step}$	Current per Winding A/Winding	Resistance per Winding Ohm	Weight kg	Stroke „A“ mm	Housing Length „B“ mm	Length „A“ mm
L2818S0604-T5x5-A	30	100	5	25	0.67	5.6	0.26	25-50	44	31.5
L2818L0604-T5x5-A	60	140	5	25	0.67	9.2	0.34	25-50	44	50.5

ORDER IDENTIFIER

L2018S0604-T3,5X1

CAUTION

The force and power ratings specified in the datasheets are based on a power-up time of approx. 10% - 20% and must be reduced accordingly for higher values. Moving against fixed end stops should be avoided.

DIMENSIONS (IN MM)

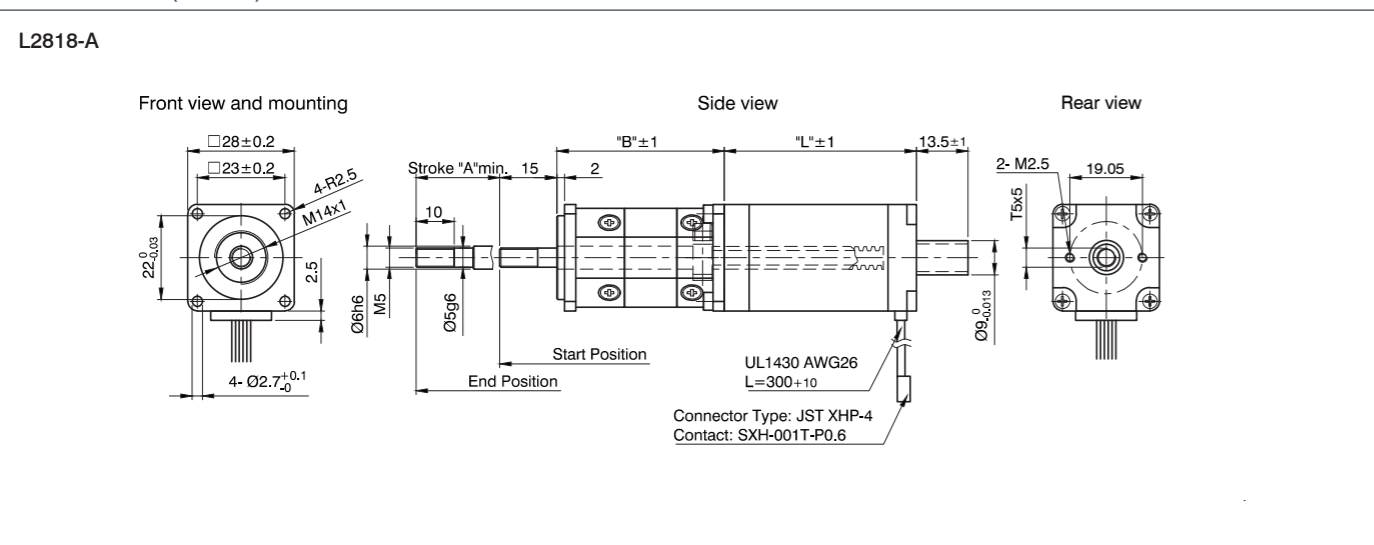



OPTION



VERSIONS

Type	Force N	Feed mm/s	Resolution $\mu\text{m}/\text{step}$	Current per Winding A/Winding	Resistance per Winding Ohm	Weight kg	Length „A“ mm
LS2818S0604-T6x1-75	60	20	5	0.67	5.6	0.13	32
LS2818S0604-T6x2-75	60	20	10	0.67	5.6	0.2	32
LS2818S0604-T5x5-75	30	100	25	0.67	5.6	0.2	32
LS2818L0604-T6x1-75	120	30	5	0.67	9.2	0.28	51
LS2818L0604-T6x2-75	120	30	10	0.67	9.2	0.28	51
LS2818L0604-T5x5-75	60	140	25	0.67	9.2	0.28	51
LS2818L1404-T6x2-75	140	40	10	1.4	2.3	0.28	51

ORDER IDENTIFIER

LS2818S0604-T6x1-75

ACCESSORIES

- LSNUT-T5x5-F Threaded Nut
- LSNUT-T6x1-F Threaded Nut
- LSNUT-T6x2-F Threaded Nut
- Nanolube Lubricant

CAUTION

The force and power ratings specified in the datasheets are based on a power-up time of approx. 10% - 20% and must be reduced accordingly for higher values. Moving against fixed end stops should be avoided.

DIMENSIONS (IN MM)

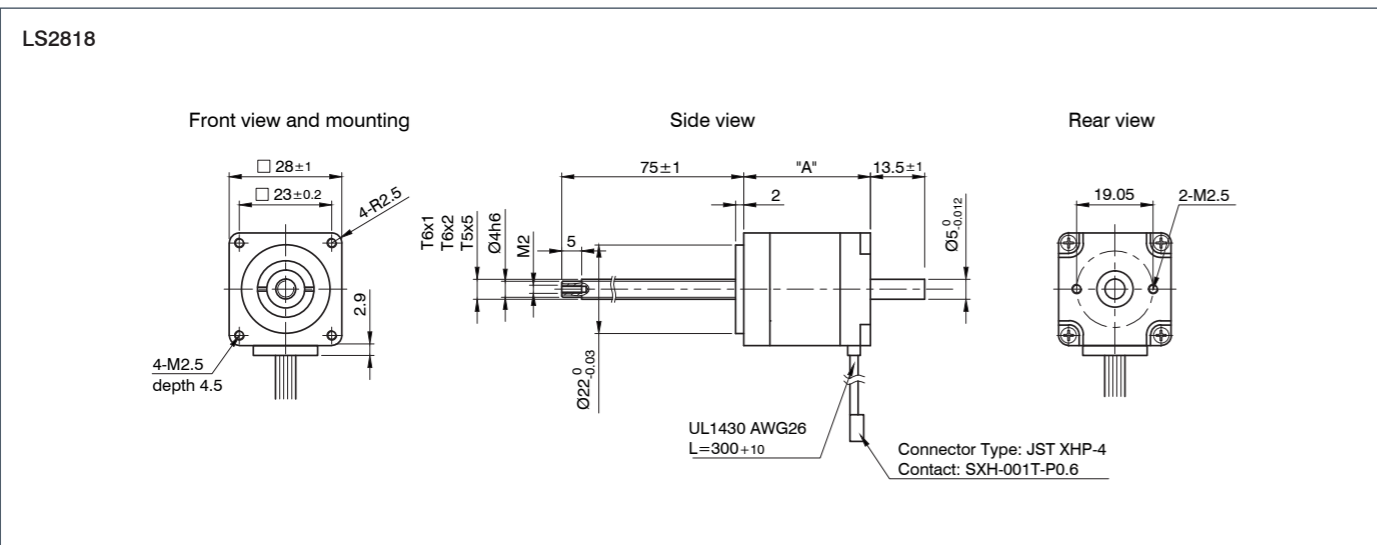

TORQUE CURVES

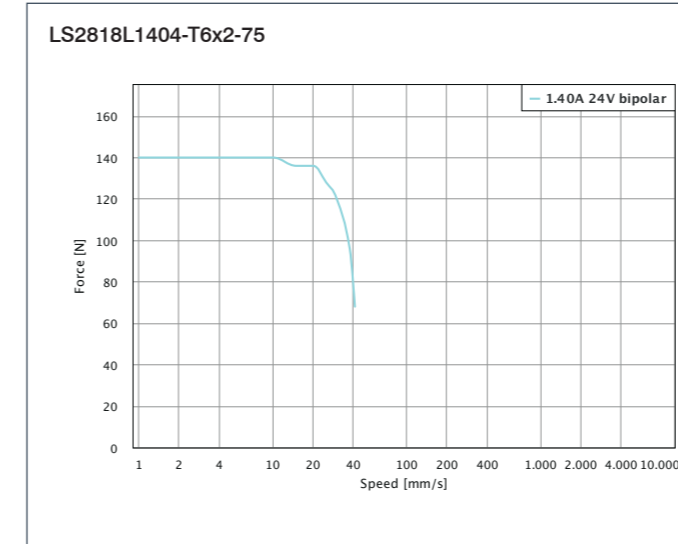



OPTION



VERSIONS

Type	Force N	Feed mm/s	Pitch of screw mm	Resolution $\mu\text{m}/\text{step}$	Current per Winding A/Winding	Resistance per Winding Ohm	Inductance per Winding mH	Weight kg	Bushing Length „L“ mm	Length „A“ mm
L3518S1204-T6X1	240	50	1	5	1.2	1.85	2	0.15	20	34
L3518S1204-T6X2	160	100	2	10	1.2	1.85	2	0.15	20	34
L3518S1204-T5X5	85	250	5	25	1.2	1.85	2	0.15	20	34

ORDER IDENTIFIER

L3518S1204-T6X1



ACCESSORIES

- ZST5-5-200-1 Threaded Screw
- ZST5-5-300-1 Threaded Screw
- ZST5-5-1050 Threaded Screw
- ZST6-1-200-1 Threaded Screw
- ZST6-1-300-1 Threaded Screw
- ZST6-1-1050 Threaded Screw
- ZST6-2-200-1 Threaded Screw
- ZST6-2-300-1 Threaded Screw
- ZST6-2-1500 Threaded Screw
- Nanolube Lubricant



CAUTION



The force and power ratings specified in the datasheets are based on a power-up time of approx. 10% - 20% and must be reduced accordingly for higher values. Moving against fixed end stops should be avoided.

DIMENSIONS (IN MM)

L3518

Front view and mounting

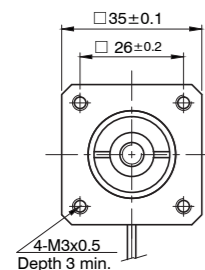

Side view

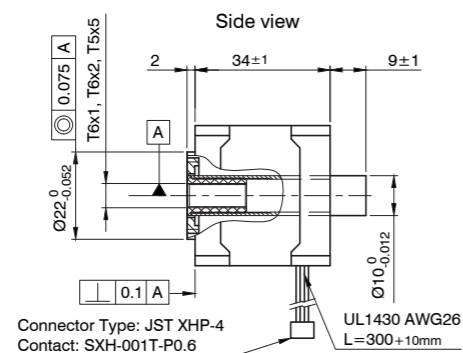

Rear view

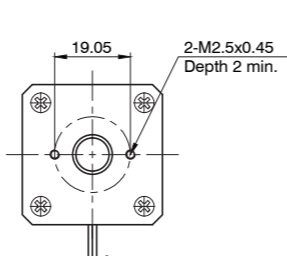

TORQUE CURVES

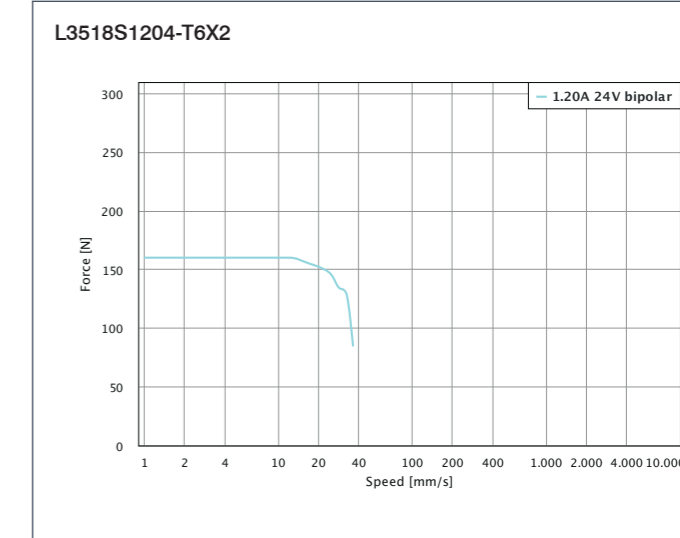
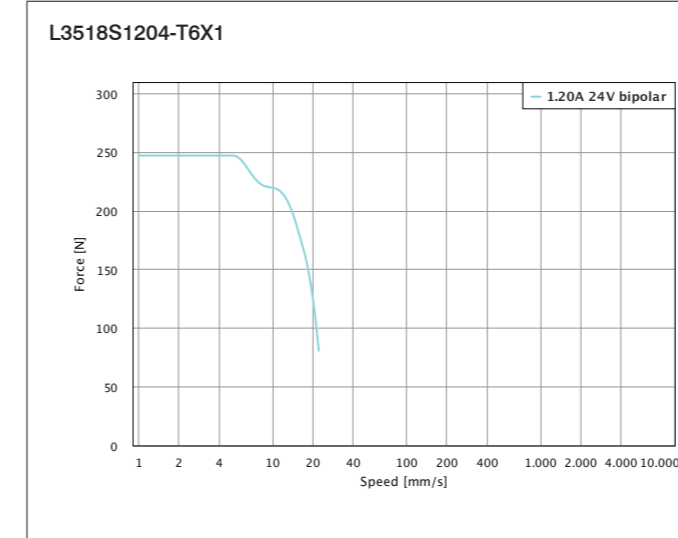



OPTION



VERSIONS

Type	Force N	Feed mm/s	Pitch of screw mm	Resolution $\mu\text{m}/\text{step}$	Current per Winding A/Winding	Resistance per Winding Ohm	Weight kg	Stroke „A“ mm	Housing Length „B“ mm	Length „L“ mm
L3518S1204-T6X1-A	240	50	1	5	1.2	1.85	0.2-0.25	25-50	43-68	34
L3518S1204-T6X2-A	160	100	2	10	1.2	1.85	0.2-0.25	25-50	43-68	34
L3518S1204-T5X5-A	85	250	5	25	1.2	1.85	0.2-0.25	25-50	43-68	34

ORDER IDENTIFIER

L3518S1204-T6X1-
 A25 = 25 mm Stroke „A“
 A50 = 50 mm Stroke „A“

ACCESSORIES

Nanolube Lubricant

CAUTION

The force and power ratings specified in the datasheets are based on a power-up time of approx. 10% - 20% and must be reduced accordingly for higher values. Moving against fixed end stops should be avoided.

DIMENSIONS (IN MM)

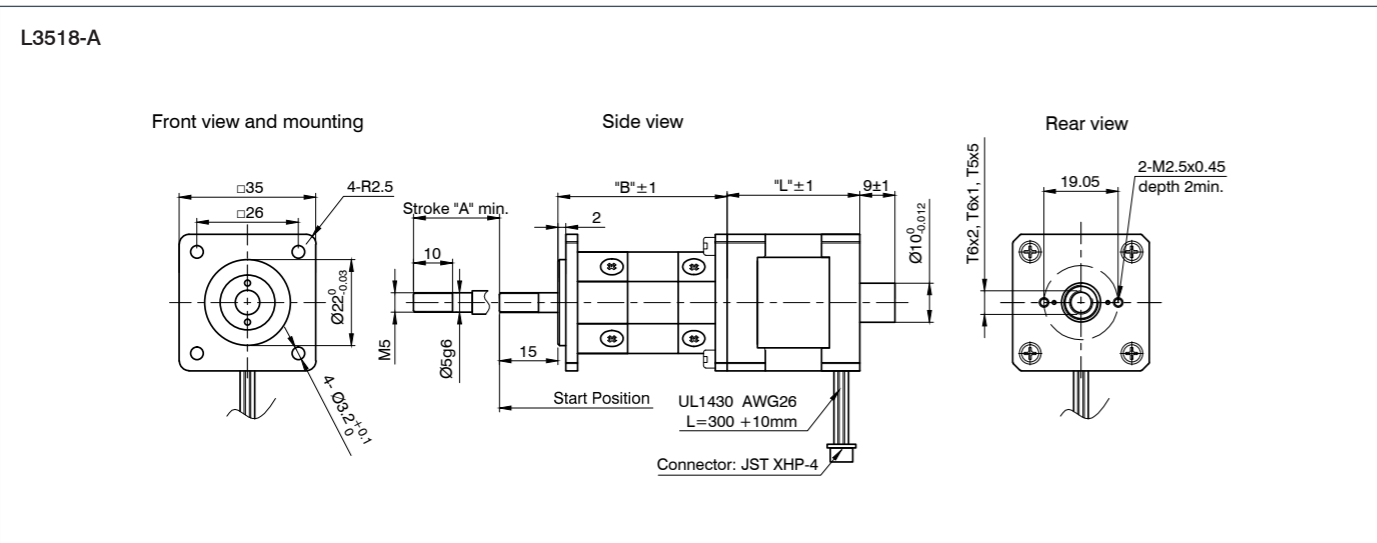

TORQUE CURVES

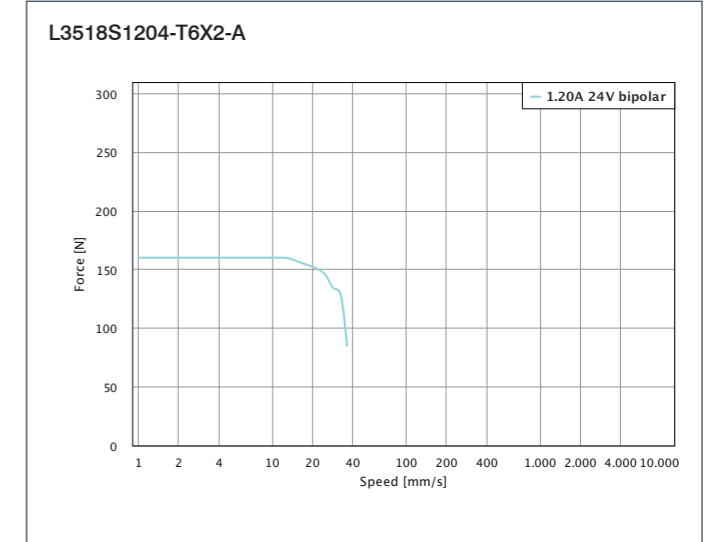
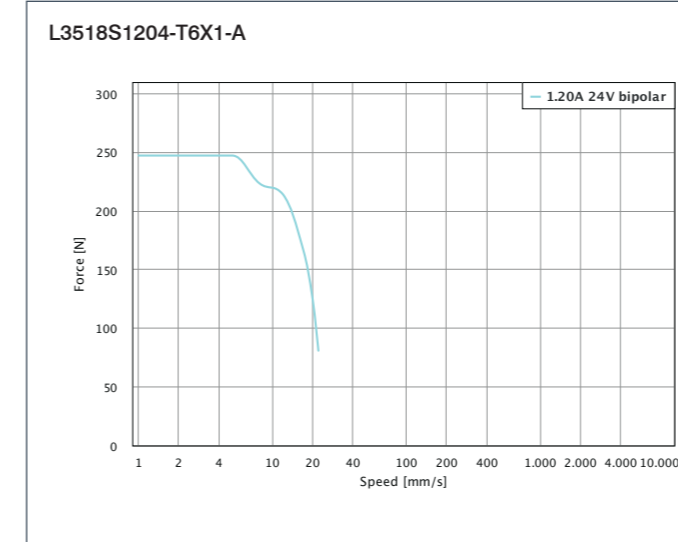

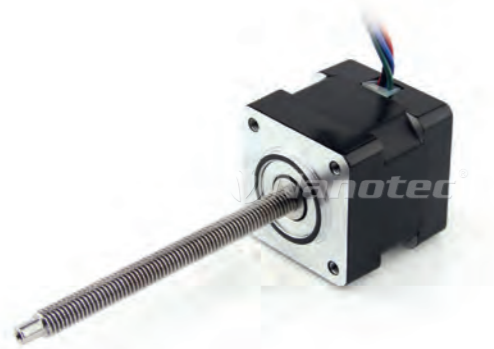

OPTION



VERSIONS

Type	Force N	Feed mm/s	Resolution $\mu\text{m}/\text{step}$	Current per Winding A/Winding	Resistance per Winding Ohm	Weight kg	Length „A“ mm
LS3518S1204-T6X1-75	240	50	5	1.2	1.9	0.15	34
LS3518S1204-T6X2-75	160	100	10	1.2	1.9	0.15	34
LS3518S1204-T5X5-75	85	250	25	1.2	1.9	0.15	34

ORDER IDENTIFIER

LS3518S1204-T6X1-75

ACCESSORIES

- LSNUT-T5x5-F Threaded Nut
- LSNUT-T6x1-F Threaded Nut
- LSNUT-T6x2-F Threaded Nut
- Nanolube Lubricant

CAUTION

The force and power ratings specified in the datasheets are based on a power-up time of approx. 10% - 20% and must be reduced accordingly for higher values. Moving against fixed end stops should be avoided.

DIMENSIONS (IN MM)

LS3518

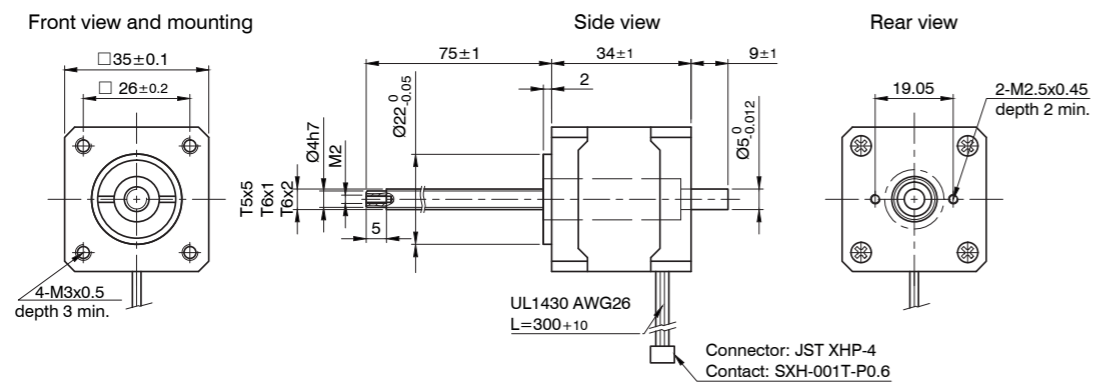

TORQUE CURVES

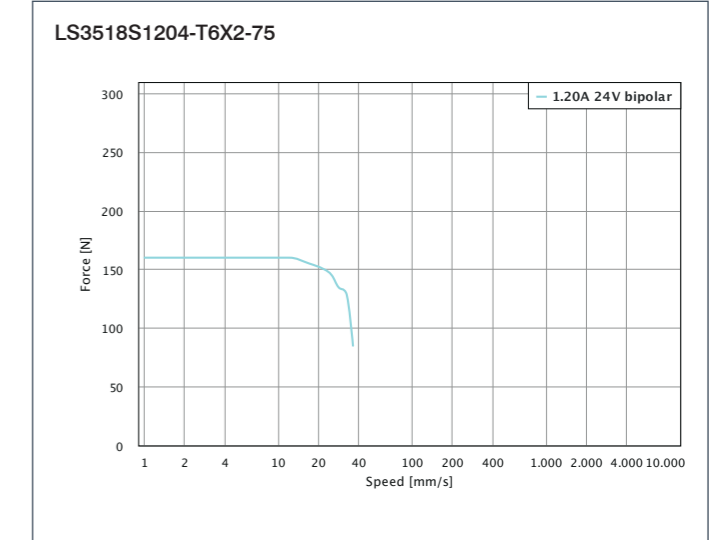
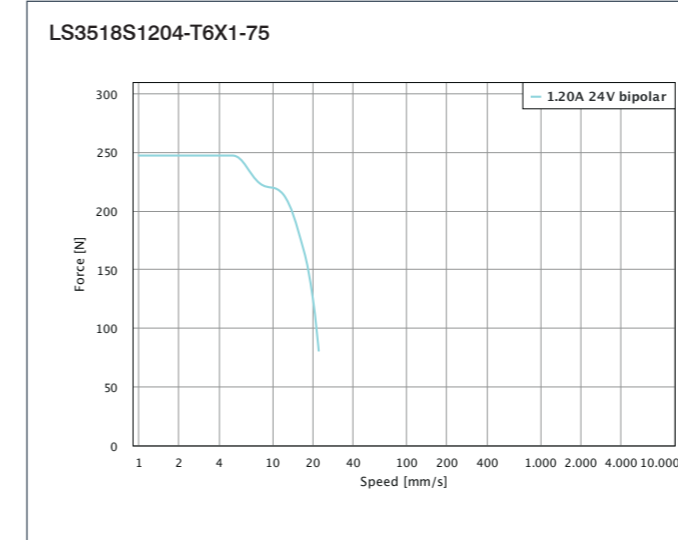

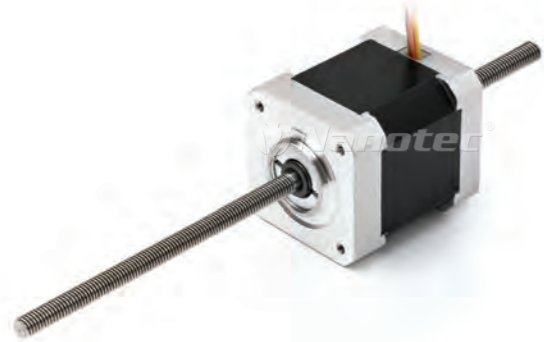

OPTION



VERSIONS

Type	Force N	Feed mm/s	Pitch of screw mm	Resolution $\mu\text{m}/\text{step}$	Current per Winding A/Winding	Resistance per Winding Ohm	Inductance per Winding mH	Weight kg	Bushing Length „L“ mm	Length „A“ mm
L4118S1404-M6X1	90	20	1	5	1.4	2	2.8	0.2	15	31
L4118L1804-M6X1	200	40	1	5	1.8	1.75	3.3	0.34	20	49
L4118S1404-T6X1	350	40	1	5	1.4	2	2.8	0.2	15	31
L4118S1404-T6X2	250	55	2	10	1.4	2	2.8	0.2	15	31
L4118S1404-T5X5	120	65	5	25	1.4	2	2.8	0.2	20	31
L4118M1804-T6X1	400	25	1	5	1.8	1.1	1.85	0.24	15	38
L4118M1804-T6X2	300	45	2	10	1.8	1.1	1.85	0.24	15	38
L4118M1804-T5X5	150	65	5	25	1.8	1.1	1.85	0.24	20	38
L4118L1804-T6X1	450	37	1	5	1.8	1.75	3.3	0.34	15	49
L4118L1804-T6X2	350	50	2	10	1.8	1.75	3.3	0.34	15	49
L4118L1804-T5X5	250	60	5	25	1.8	1.75	3.3	0.34	20	49

ORDER IDENTIFIER

L4118S1404-M6X1



ACCESSORIES

- ZSM6-1-200 Threaded Screw
- ZSM6-1-300 Threaded Screw
- ZSM6-1-1000 Threaded Screw
- ZST6-1-200-1 Threaded Screw
- ZST6-1-300-1 Threaded Screw
- ZST6-1-1050 Threaded Screw
- ZST6-2-200-1 Threaded Screw
- ZST6-2-300-1 Threaded Screw
- ZST6-2-1500 Threaded Screw
- ZST5-5-200-1 Threaded Screw
- ZST5-5-300-1 Threaded Screw
- ZST5-5-1050 Threaded Screw
- Nanolube Lubricant



CAUTION

The force and power ratings specified in the datasheets are based on a power-up time of approx. 10% - 20% and must be reduced accordingly for higher values. Moving against fixed end stops should be avoided.

DIMENSIONS (IN MM)

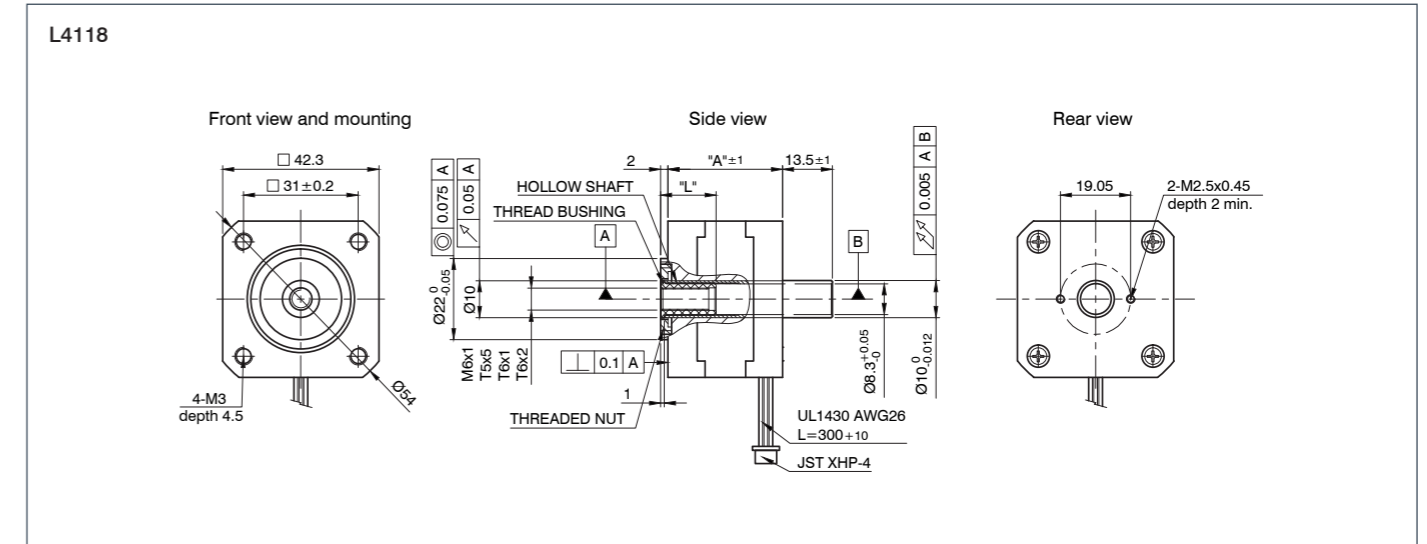

TORQUE CURVES

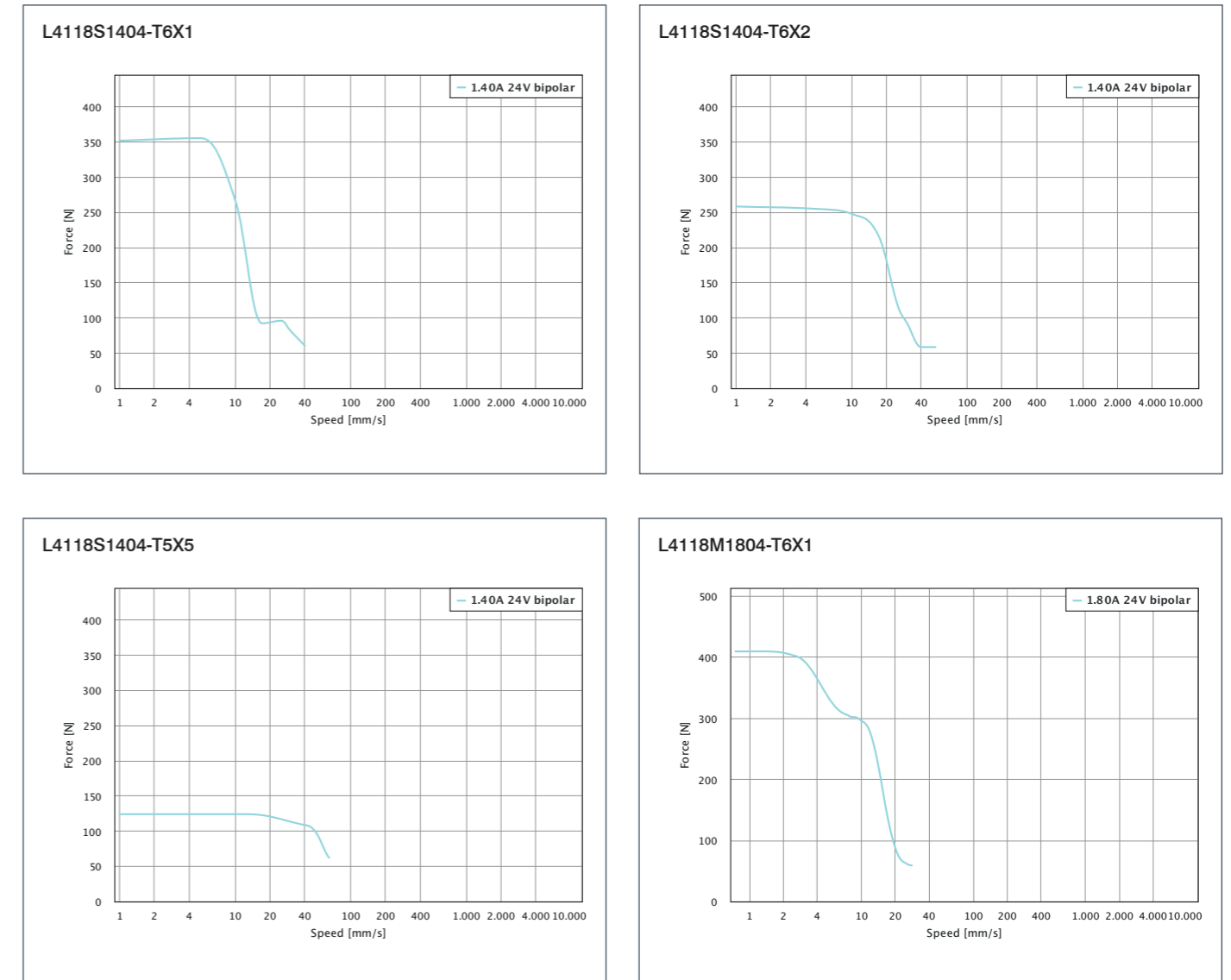

TORQUE CURVES

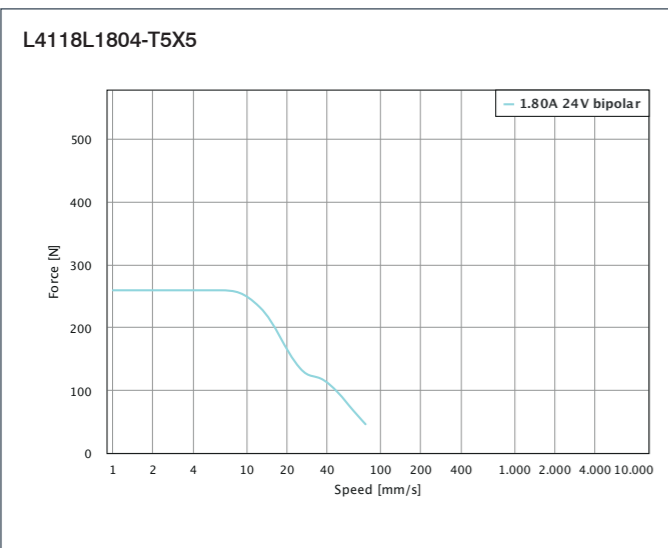
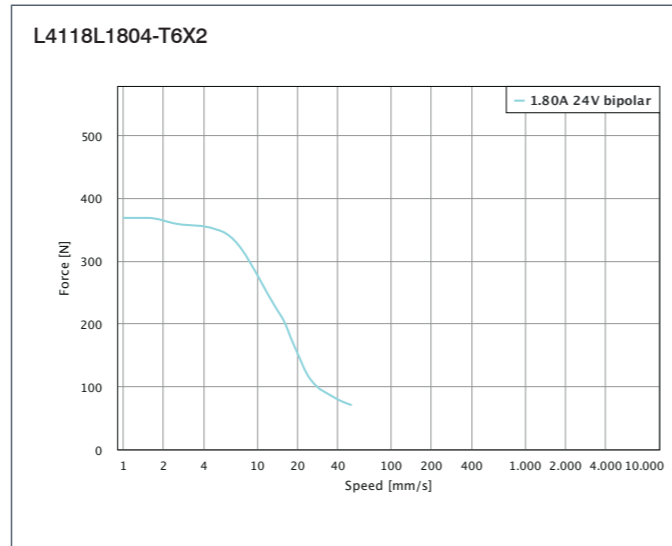
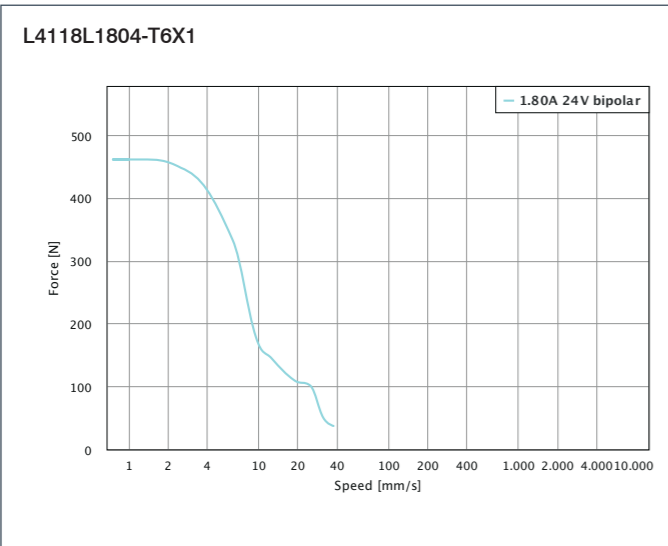
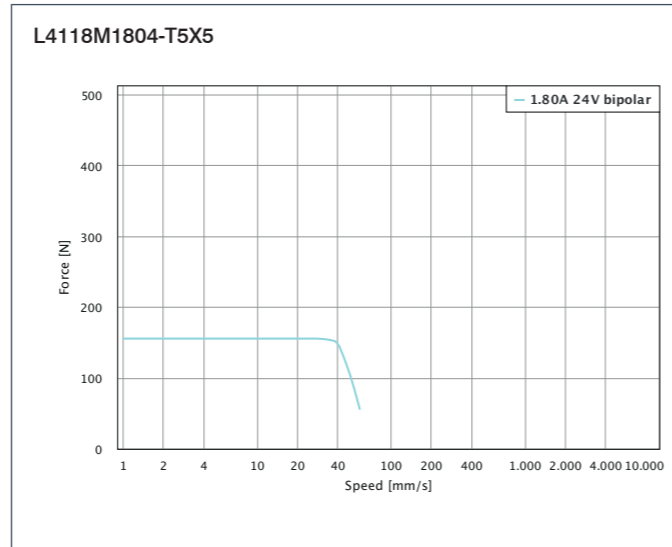
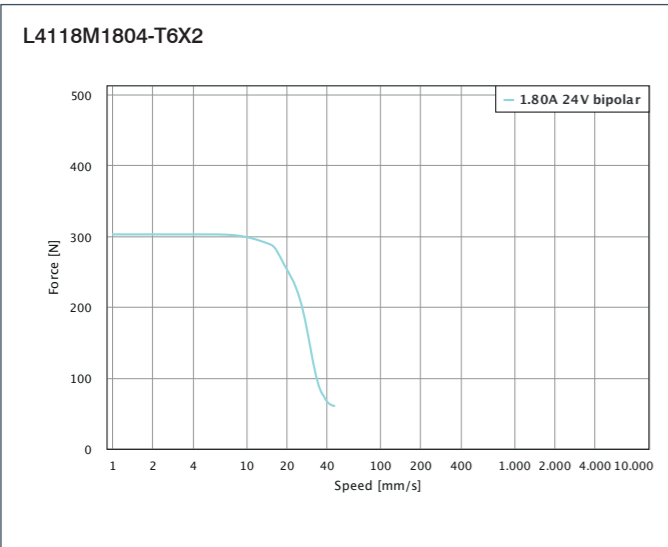

Notes section with horizontal lines for writing.



OPTION



VERSIONS

Type	Force N	Feed mm/s	Pitch of screw mm	Resolution $\mu\text{m}/\text{step}$	Current per Winding A/Winding	Resistance per Winding Ohm	Weight kg	Stroke „A“ mm	Housing Length „B“ mm	Length „A“ mm
L4118S1404-T6x1-A	350	40	1	5	1.4	2	0.35-0.4	25-50	47-72	31
L4118S1404-T6x2-A	250	55	2	10	1.4	2	0.35-0.4	25-50	47-72	31
L4118S1404-T5x5-A	120	65	5	25	1.4	2	0.35-0.4	25-50	47-72	31
L4118M1804-T6x1-A	400	25	1	5	1.8	1.1	0.35-0.4	25-50	47-72	38
L4118M1804-T6x2-A	300	45	2	10	1.8	1.1	0.35-0.4	25-50	47-72	38
L4118M1804-T5x5-A	150	65	5	25	1.8	1.1	0.35-0.4	25-50	47-72	38
L4118L1804-T6x1-A	450	37	1	5	1.8	1.75	0.35-0.4	25-50	47-72	49
L4118L1804-T6x2-A	350	50	2	10	1.8	1.75	0.35-0.4	25-50	47-72	49
L4118L1804-T5x5-A	250	60	5	25	1.8	1.75	0.35-0.4	25-50	47-72	49

ORDER IDENTIFIER

L4118S1404-T6X1-
 A25 = 25 mm Stroke „A“
 A50 = 50 mm Stroke „A“



CAUTION

The force and power ratings specified in the datasheets are based on a power-up time of approx. 10% - 20% and must be reduced accordingly for higher values. Moving against fixed end stops should be avoided.

DIMENSIONS (IN MM)

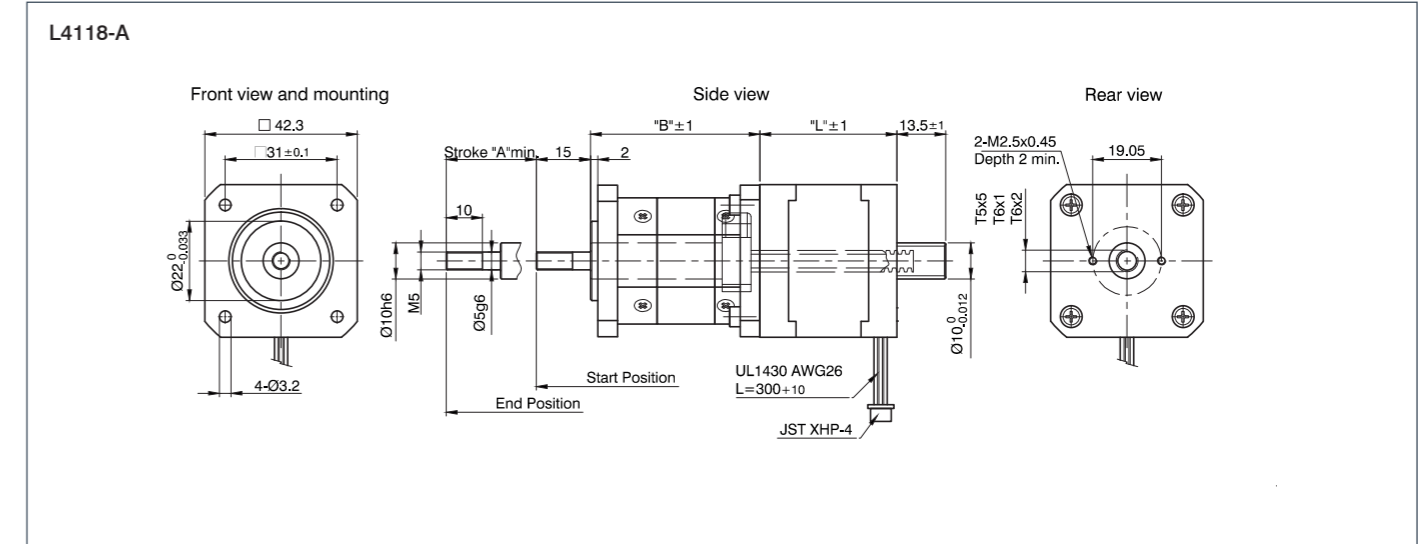

TORQUE CURVES

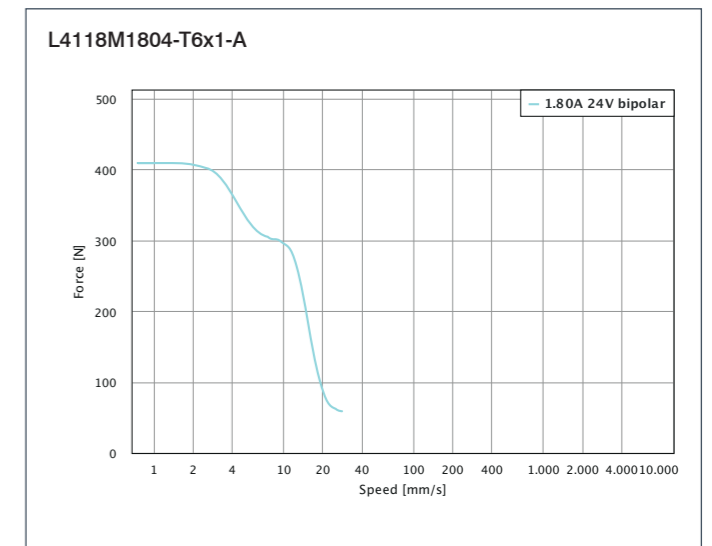
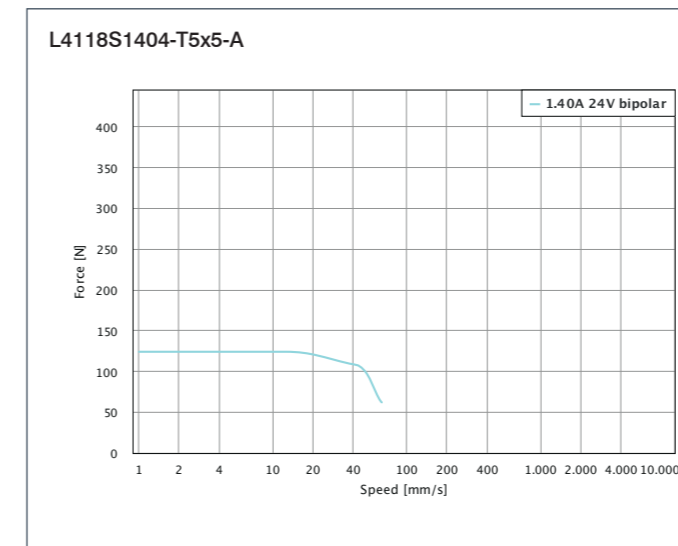
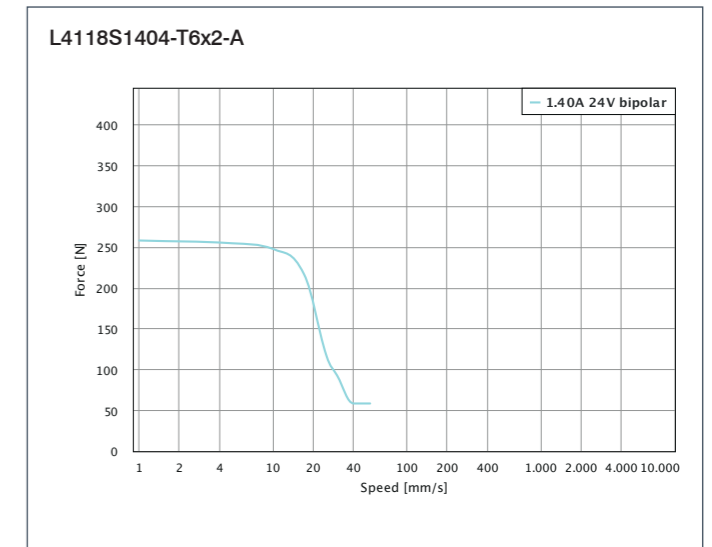
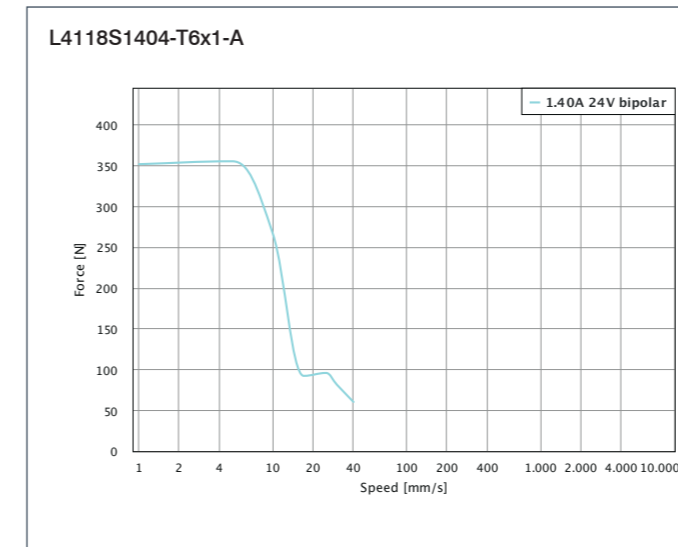

TORQUE CURVES

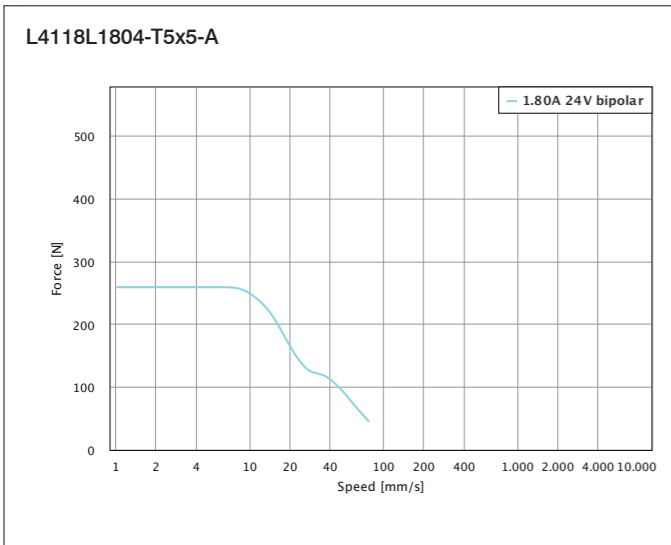
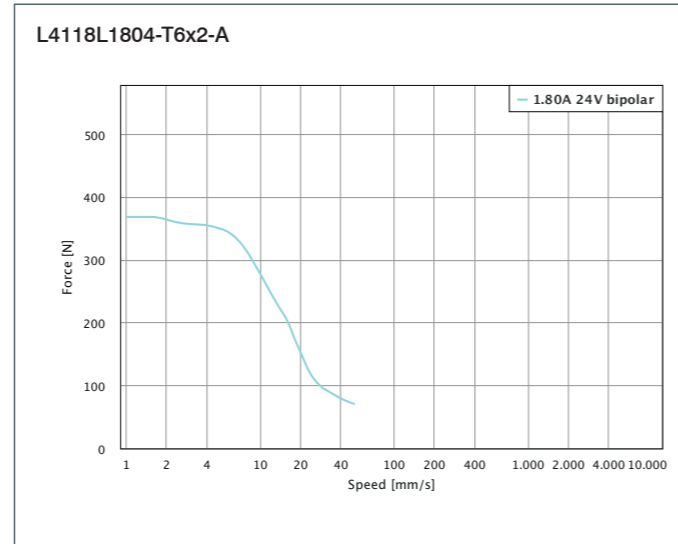
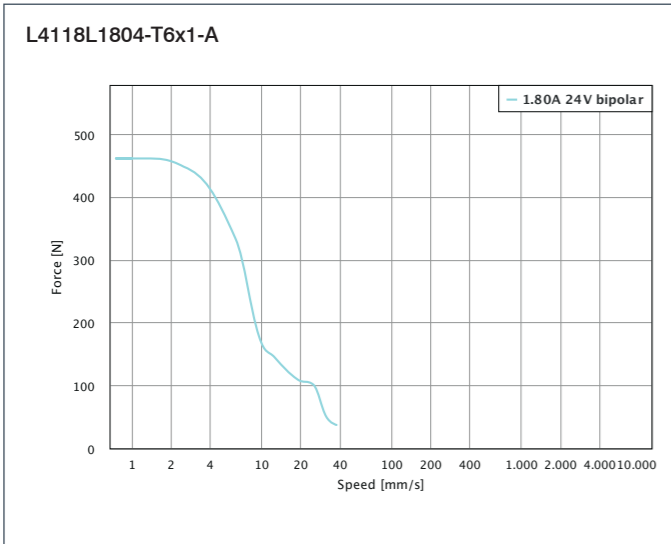
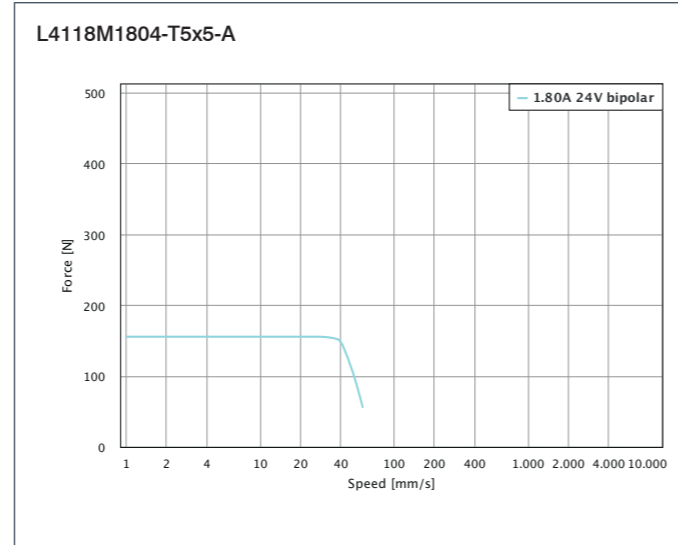
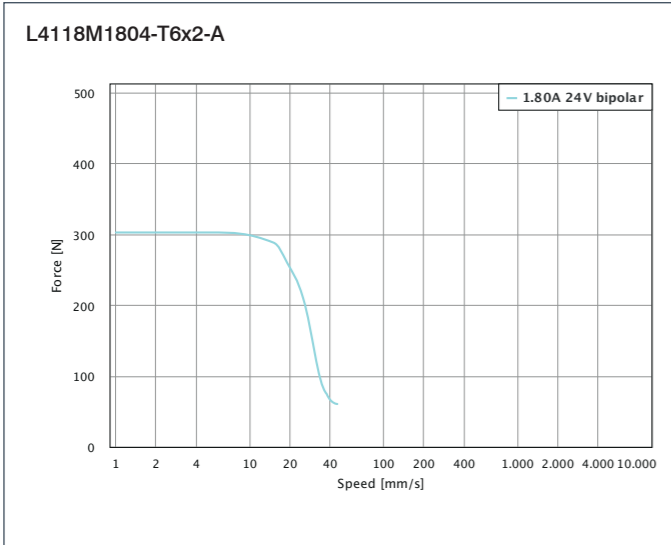

Notes section with horizontal lines for writing.

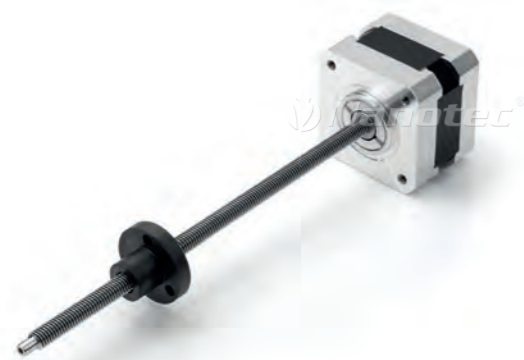

OPTION



VERSIONS

Type	Force N	Feed mm/s	Resolution $\mu\text{m}/\text{step}$	Current per Winding A/Winding	Resistance per Winding Ohm	Thread Length mm	Weight kg
LS4118S1404-T6x1	200	50	5	1.4	2	75 mm - 150 mm	0.2
LS4118S1404-T6x2	200	50	10	1.4	2	75 mm - 150 mm	0.2
LS4118S1404-T5x5	100	250	25	1.4	2	75 mm - 150 mm	0.2

ORDER IDENTIFIER

LS4118S1404-T6x1-
 150 = 150 mm Thread Length
 75 = 75 mm Thread Length

ACCESSORIES

LSNUT-T5x5-F Threaded Nut
LSNUT-T6x1-F Threaded Nut
LSNUT-T6x2-F Threaded Nut
Nanolube Lubricant

CAUTION

The force and power ratings specified in the datasheets are based on a power-up time of approx. 10% - 20% and must be reduced accordingly for higher values. Moving against fixed end stops should be avoided.

DIMENSIONS (IN MM)

LS4118

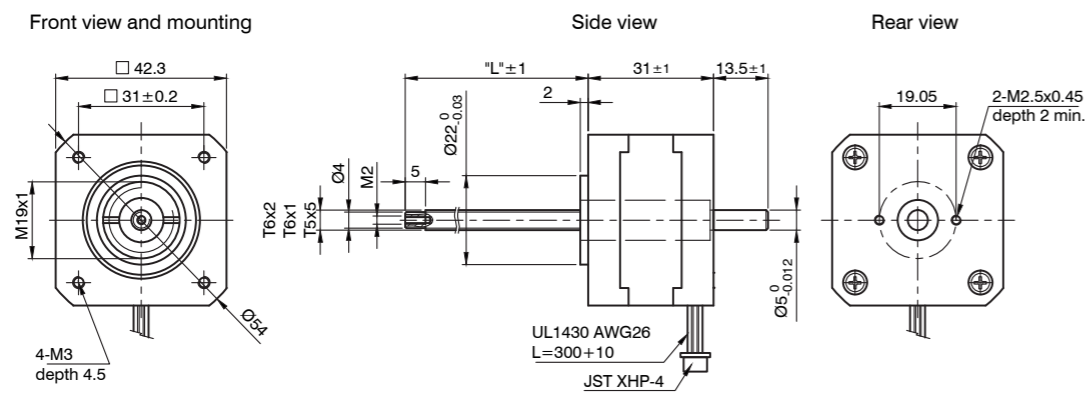

TORQUE CURVES

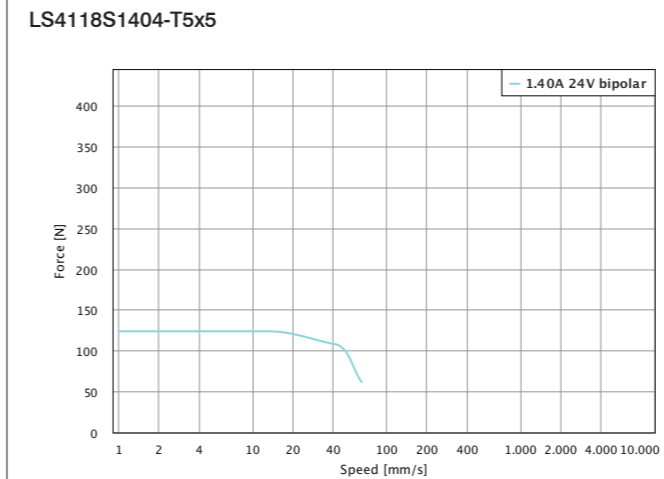
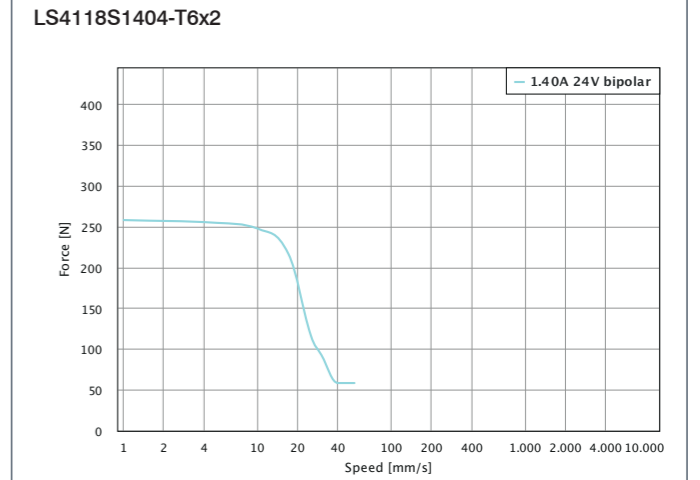
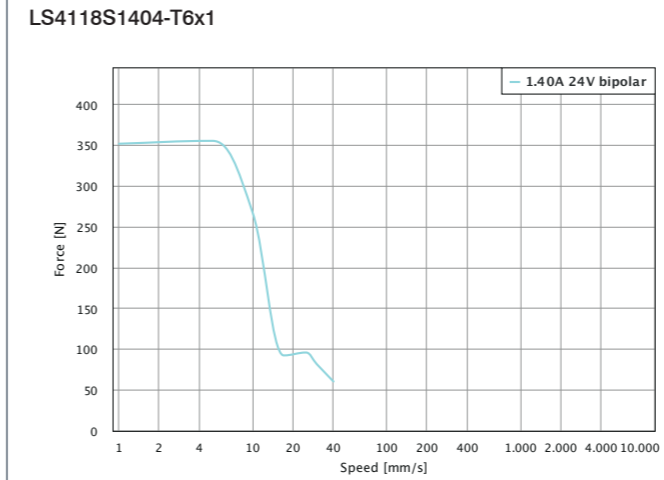



OPTION



VERSIONS

Type	Force N	Feed mm/s	Pitch of screw mm	Resolution $\mu\text{m}/\text{step}$	Current per Winding A/Winding	Resistance per Winding Ohm	Inductance per Winding mH	Weight kg	Bushing Length „L“ mm	Length „A“ mm
L5918S2008-T10X2	800	70	2	10	2	1.5	2.6	0.65	25	51
L5918L3008-T10X2	1000	80	2	10	3	1	2.2	1	25	76

ORDER IDENTIFIER

L5918S2008-T10X2



ACCESSORIES

- ZST10-2-200-1 Threaded Screw
- ZST10-2-300-1 Threaded Screw
- ZST10-2-1050 Threaded Screw
- Nanolube Lubricant



CAUTION

The force and power ratings specified in the datasheets are based on a power-up time of approx. 10% - 20% and must be reduced accordingly for higher values. Moving against fixed end stops should be avoided.

DIMENSIONS (IN MM)

L5918

Front view and mounting

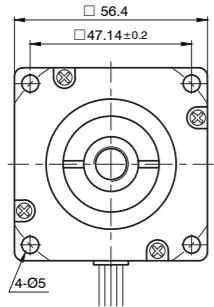

Side view

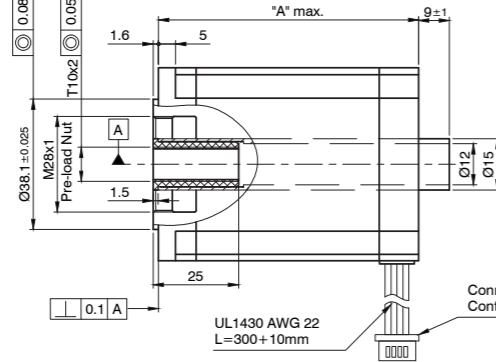

Rear view

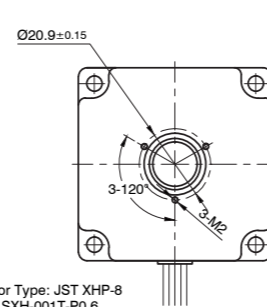

Connector Type: JST XHP-8
Contact: SXH-001T-P0.6

TORQUE CURVES

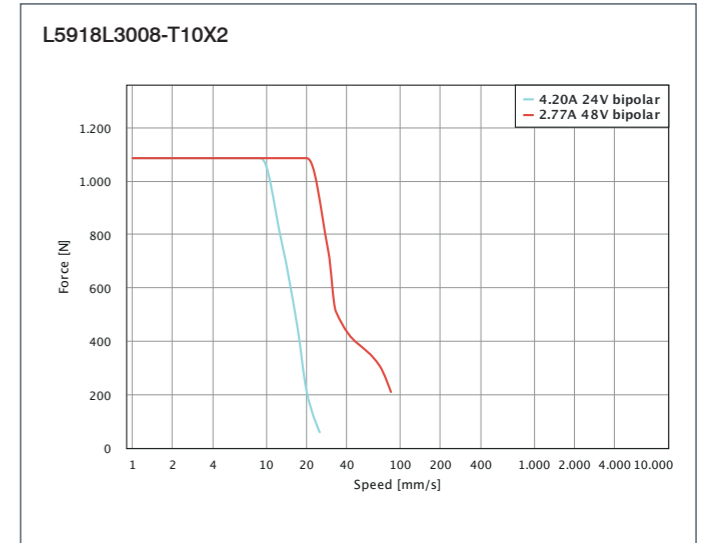
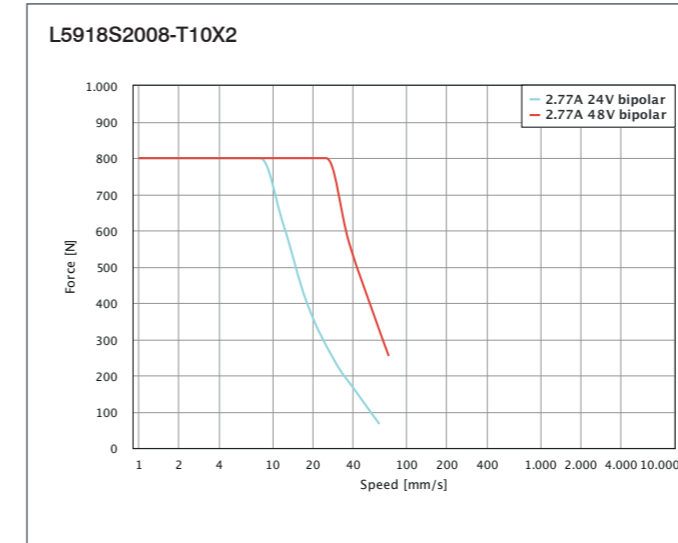



OPTION



VERSIONS

Type	Force N	Feed mm/s	Pitch of screw mm	Resolution $\mu\text{m}/\text{step}$	Current per Winding A/Winding	Resistance per Winding Ohm	Weight kg	Stroke „A“ mm	Housing Length „B“ mm	Length „A“ mm
L5918S2008-T10x2-A	800	70	2	10	2	1.5	0.8-0.85	25-50	47-72	51
L5918L3008-T10x2-A	1000	80	2	10	3	1	1.15-1.20	25-50	47-72	76

ORDER IDENTIFIER

L5918S2008-

A25 = 25 mm Stroke „A“
A50 = 50 mm Stroke „A“

CAUTION

The force and power ratings specified in the datasheets are based on a power-up time of approx. 10% - 20% and must be reduced accordingly for higher values. Moving against fixed end stops should be avoided.

DIMENSIONS (IN MM)

L5918-A

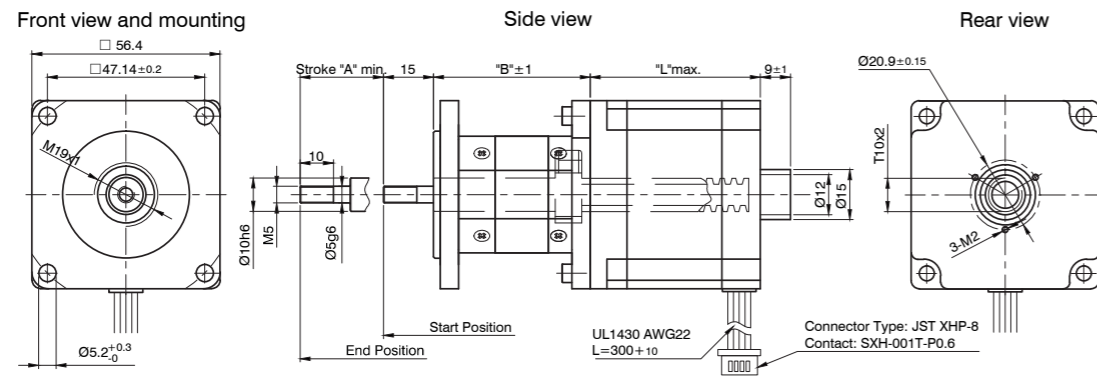

TORQUE CURVES

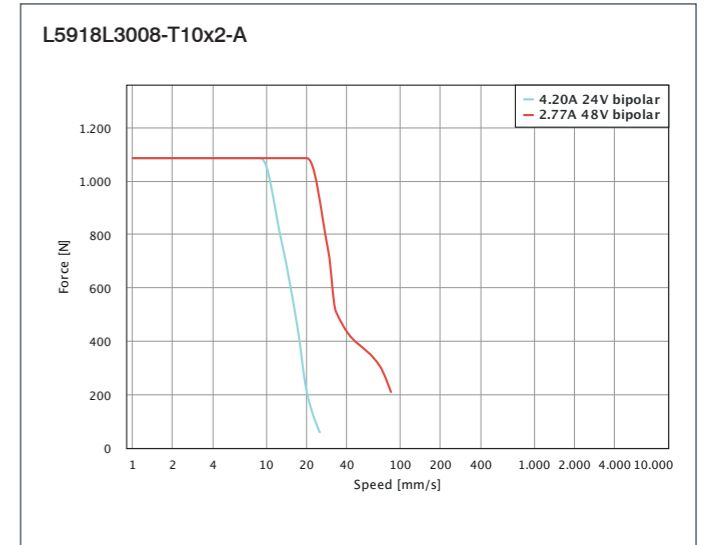
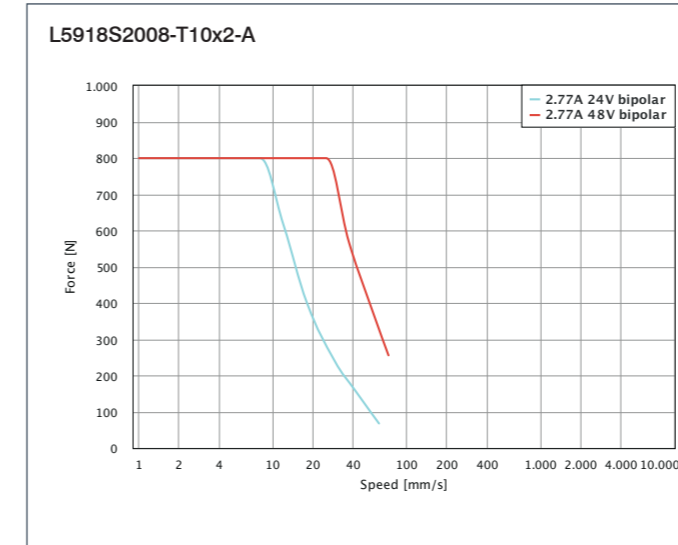



OPTION



VERSIONS

Type	Force N	Feed mm/s	Resolution $\mu\text{m}/\text{step}$	Current per Winding A/Winding	Resistance per Winding Ohm	Weight kg	Length „A“ mm
LS5918S2008-T10X2-75	800	70	10	2	1.5	0.85	51

ORDER IDENTIFIER

LS5918S2008-T10X2-75

ACCESSORIES

LSNUT-T10X2-F Threaded Nut
Nanolube Lubricant

CAUTION

The force and power ratings specified in the datasheets are based on a power-up time of approx. 10% - 20% and must be reduced accordingly for higher values. Moving against fixed end stops should be avoided.

DIMENSIONS (IN MM)

LS5918

Front view and mounting

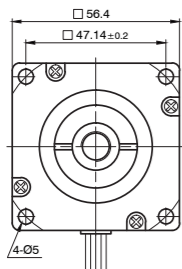

Side view

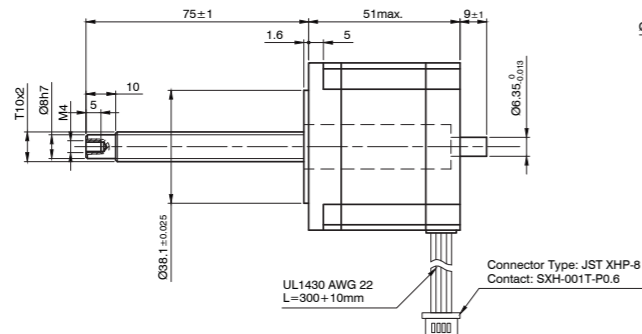

Rear view

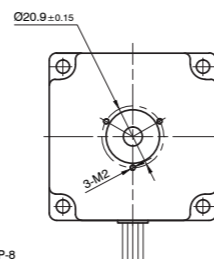

TORQUE CURVES

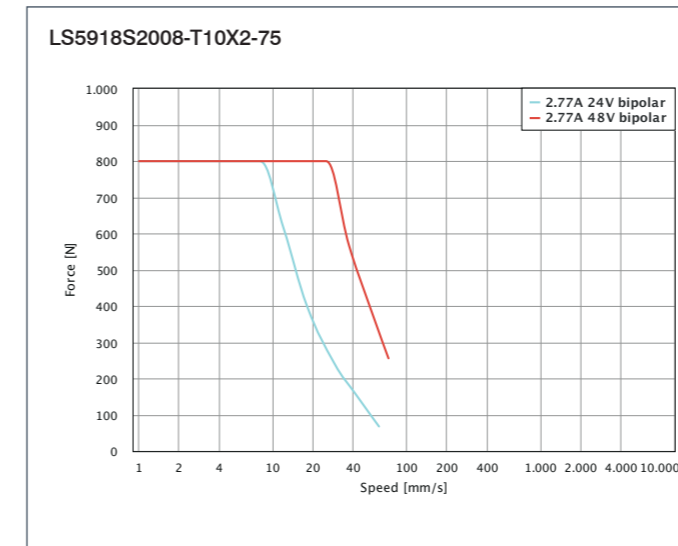

CONTROL OPTIONS FOR PLUG & DRIVE MOTORS AND MOTOR CONTROLLERS

Just as our motor controllers, our Plug & Drive motors can be controlled via a wide variety of methods. Dip switches, configuration files or software enable the user to switch between the different methods. Information on which control version can be used in each case is provided in the data sheets.

Our motor controllers are divided into two device generations:

SMCI, PD-N: motor controllers that can be easily configured with NanoPro and NanoCAN; for use with USB, RS485 and CANopen; programmable with NanoJ

C, N, PD-C: real-time motor controllers and PD motors with a large variety of field bus options; programmable with NanoJ V2

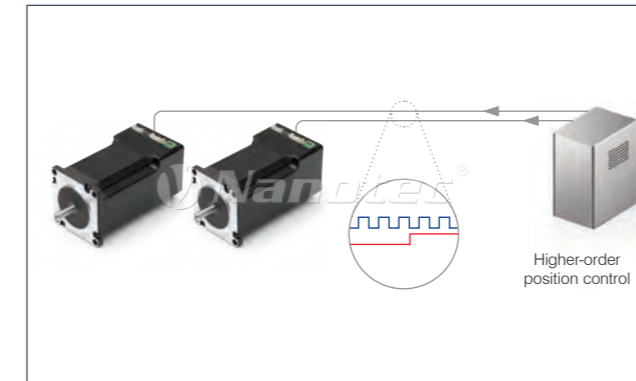
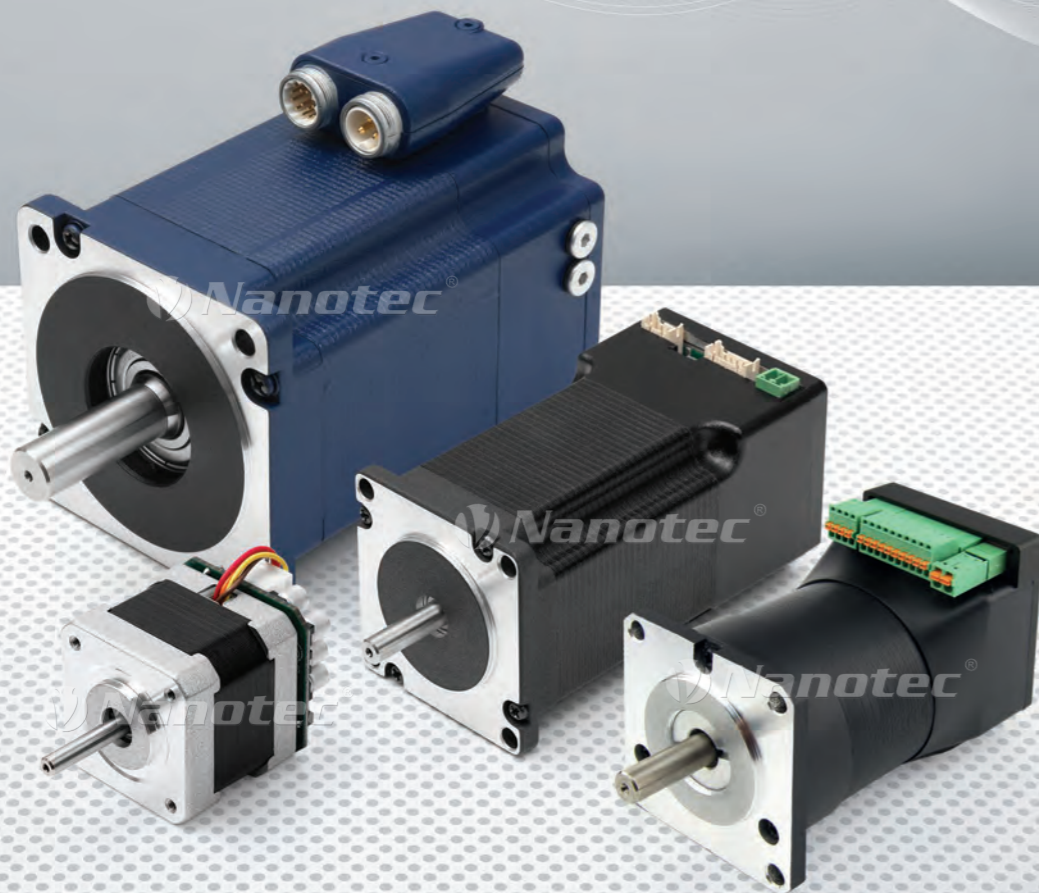

Clock & direction

- Microstep to one 64th of a step
- Step multiplication/microstep emulation so that the smooth running of the microstep can also be used with older higher-level controllers that only output full or half steps.

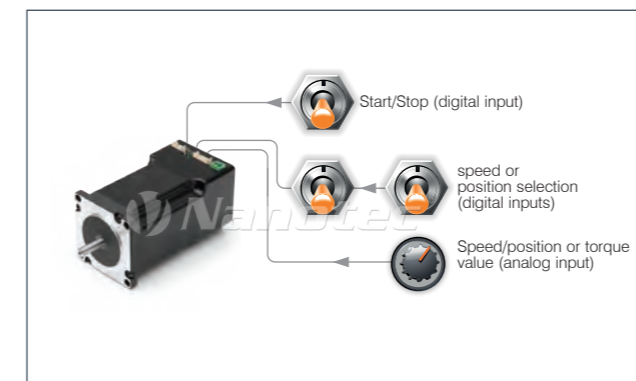

Control via digital and analog inputs

- Motor controllers that are configurable with NanoPro: Up to 32 movement sequences (position or speed profiles) can be stored in the motor controller, selected using digital inputs, started and stopped. Also speed, position or torque can be controlled via the analog input. For additional functions (e.g. reference switch, enable) Inputs are freely configurable.
- Motor controllers that are programmable with NanoJ V2: digital and analog I/Os can be read out every millisecond and processed in a sequence program.

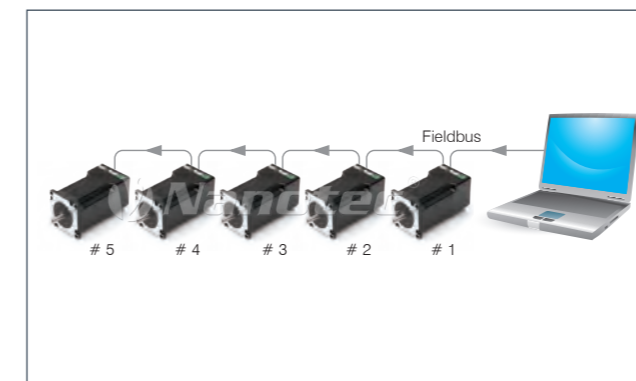

Control via fieldbus

- Open protocol via RS232/RS485 with an adjustable baud rate of 9.6–115 Kbit for motor controllers configurable with NanoPro
- Diverse fieldbus options for Controller with NanoJ V2:

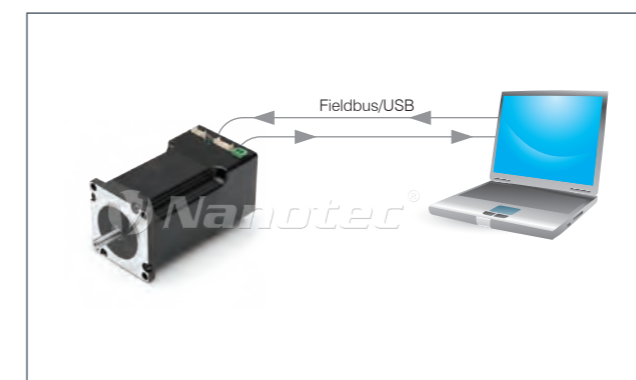

Sequence control with NanoJ/NanoJ V2

- C-based programming language; these programs run autonomously (without a connected PC or master) directly on the motor controller or Plug & Drive motor
- Access to all controller parameters and inputs/outputs
- Variables, branches, loops, logical and mathematical functions
- Programs can be stored in the motor controller via Fieldbus/USB

Closed loop-capable stepper motors merge the benefits of stepper and servo motor technology. They are smooth-running with less resonance than stepper motors. They offer position feedback and control, short settling and release times and no longer exhibit step loss. They are an alternative to a stepper motor if energy efficiency, smooth running and load tolerance are required. Compared to servo motors, they have advantages due to high torque at low speeds, short settling times and correct positioning without back swing.

What is closed loop?

Sinusoidal commutation via encoder with field-oriented control is referred to as the closed-loop process. The rotor position is detected using the encoder's signals and sinusoidal phase currents are generated in the motor windings. Controlling the vector of the magnetic field ensures that the stator magnetic field is vertical relative to the rotor magnetic field and the field strength corresponds exactly to the desired torque. The controlled current level in the windings provides uniform motor force and leads to a particularly quiet-running motor that can be controlled precisely.

True/pseudo closed loop

There are stepper motors that dress themselves up as being closed loops and work with encoders but do not provide any field-oriented control with sinusoidally commutated current control. They only check the step position, and cannot correct step losses during operation. True closed loop with field-oriented regulation compensates step losses during the run or prevents them from occurring by increasing the motor current.

Advantages over standard stepper motors

A stepper motor is used wherever movement to fixed positions is required. The classic stepper motor transfers electric energy into precise mechanical movements as long as the motor's torque is not exceeded. Since there is no position feedback or control present, the motor loses steps if unexpected load jumps or resonance occurs and it no longer moves to the desired position. A closed-loop stepper motor can readjust in those instances and reach the specified position reliably. Using an open loop, a standard stepper motor is always operated with the same current regardless of the load and it therefore becomes relatively hot in many applications. By controlling current in a closed loop, the current level can be adapted to the required torque; no unnecessary lost heat is produced and energy consumption drops accordingly.

Advantages over servo motors

In many cases, closed-loop stepper motors from Nanotec are an alternative to servo drives, such as in winding applications or belt drives. The speed and position, and even the torque, can be controlled with precision. This not only achieves the highest maximum torque, the best efficiency and the best dynamics, it also achieves the lowest torque ripple and excellent running smoothness.

Applications for closed loop systems:

Dosing pumps, filler systems, semi-conductor mounting, wafer production, industrial sewing machines, and more. Textile machines, robotics, test and optical inspection systems, tape and belt drives, general multi-axis applications and applications requiring smooth operation, short settling times or accurate positioning.

Energy efficiency

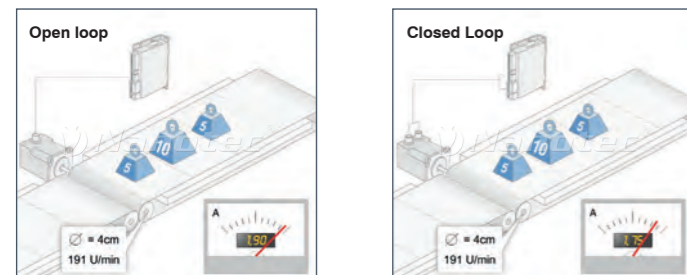

In an open loop, the stepper motor is dimensioned such that it is certain to move the maximum required load. For this reason, normally a safety factor of 20% is calculated, which amounts to wasted energy in the application. When the load is reduced, the open loop motor cannot react and wastes even more energy.

Service life

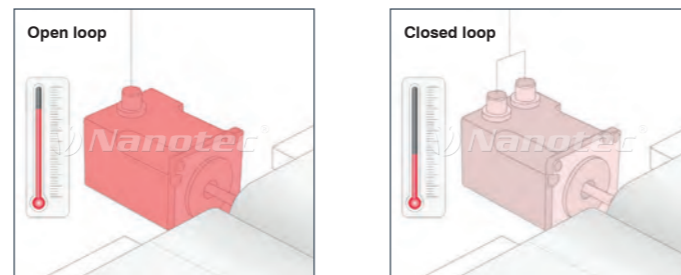

Efficient power regulation generates less heat in the motor, which stays significantly cooler. Reduced heating protects the motor bearings.

Overload

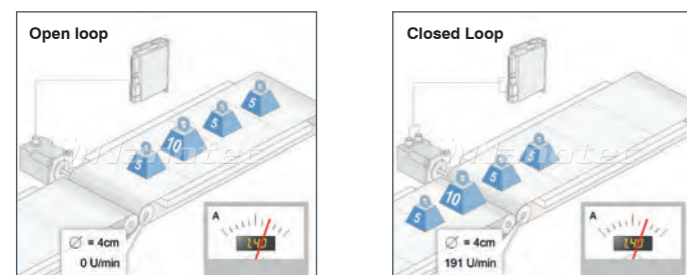

With a 20% safety reserve and a design for a continuous load of 20 kg, an additional load of only 5 kg exceeds the power reserve and the open-loop drive stops without an error message. By contrast, with its overload reserve the closed loop stepper motor can handle this load increase easily.

Resonances

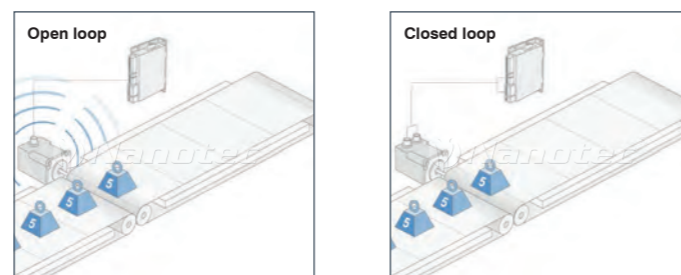

Resonance frequencies occurring in the open loop depend on external loads (the greater the torque reserve, the greater is the resonance stimulation) and can bring the motor to a stop. In closed loop mode, the motor receives only as much energy as needed for the external load; the torque reserve and its resonance stimulation do not exist, so there is practically no resonance behavior.

- Multi-axis applications (Ethernet, EtherCAT, CANopen)
- Positioning tasks with load changes
- Windings
- Belt drives (start/stop, positioning)
- Dosing pumps, filler systems
- Semi-conductor mounting
- Wafer production
- Textile machines, industrial sewing machines
- Robotics
- Testing and inspection systems
- Applications that require smooth operation, short settling times and precision positioning

Linear axes (for processing, assembling, etc.)

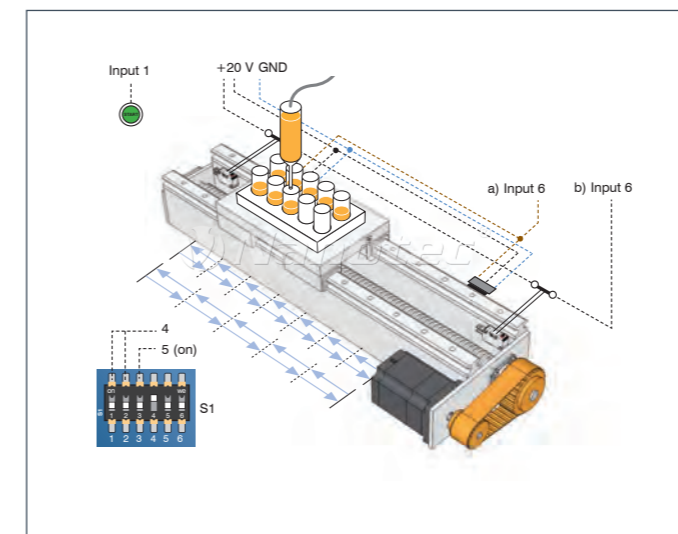

Conveyor belts

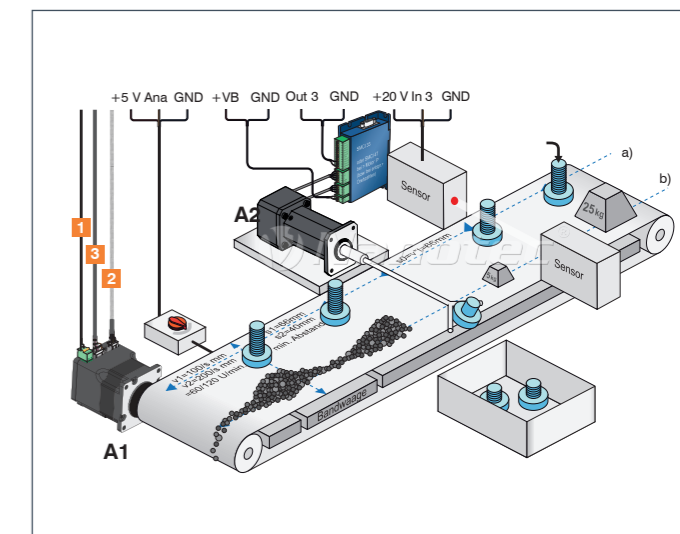

Decentralized flow control

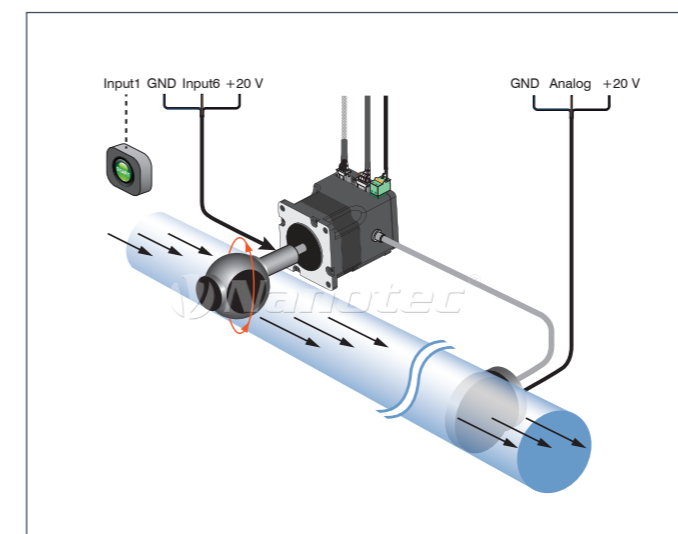

Winding and laying

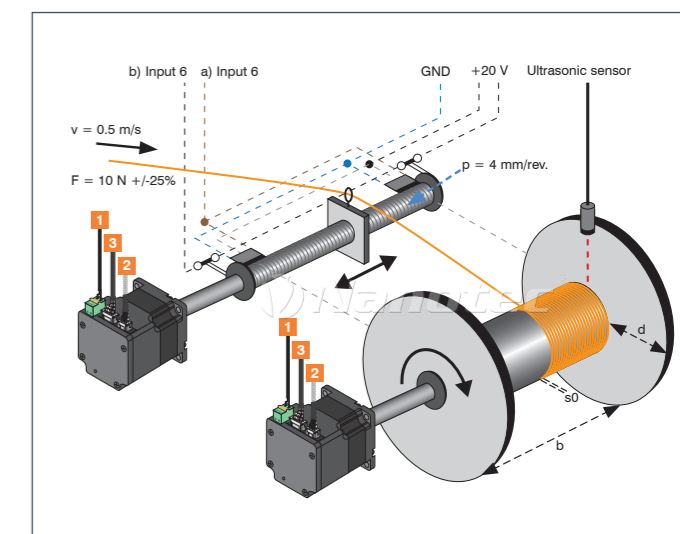

dspDrive® – Software-based current control with high resolution in the open loop

In the newest generation of Nanotec hardware, the current in the motor is no longer controlled by an integrated component but directly by a digital signal processor instead. Compared to commercially available ICs, which only provide a resolution of 6 or 8 bits for measuring current in the winding and specifying the target current, the entire control process can be carried out using 12-bit resolution with the new dspDrive. The parameters of the PI current controller are adjusted depending on speed.

This has the following application advantages:

- Very quiet, low-resonance operation with sinusoidal current waveform in the windings. Jumps and noise, which encourage the motor towards resonance, no longer occur thanks to the high resolution of the control.

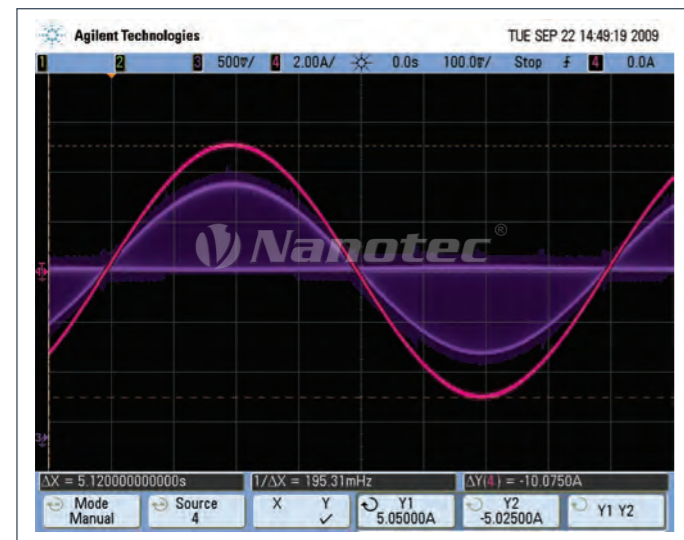

- Even more flexible: Now 3-phase stepper motors and BLDC motors can be controlled by the direct activation of half-bridges using DSP, just like their 2-phase counterparts.

Sinusoidal commutation with encoder in ClosedLoop operation

In contrast to conventional stepper motor controllers where only the motor is actuated or the position adjusted via the encoder, sinusoidal commutation controls the stator magnetic field via the encoder as in a servo motor. The stepper motor behaves no different than a multi-pole servo motor in this operating type, i.e. classic stepper motor noises and resonance are gone. The motor is capable of no longer losing steps up to its maximum torque. The current level is always adjusted to the currently needed torque by the control; as a result, current consumption and heat generation are reduced significantly compared to a classic stepper motor controller if the maximum torque is not used continuously. Especially with speeds up to 1500 rpm or torques up to 10 Nm, the sinus commutated stepper motor presents an economic alternative to conventional servo systems as, in contrast to these, a direct drive without gears is often possible.

Application programs with NanoJ

The integrated Java-based NanoJ programming language can be used to implement complete autonomous application programs on the motor controllers. Querying and setting digital and analog I/Os and accessing all of the parameters for a movement program turns the motor controller into a full-fledged device controller in conjunction with variables, loops and mathematical functions and everything that distinguishes a full-fledged higher level language. The programs can be created, compiled directly and written to the motor controller with the free NanoJ Easy editor.

```

1:  atactic int CalculateTargetPos (
2:      int pos = io.DesAnalogInput ( 1 )
3:      int pos = (pos * 2) + 1000;
4:      return pos;
5:
6:      public static void main ( )
7:      {
8:          //NanoJ: void main ( )
9:          drive.SetTargetPos ( 1 );
10:         drive.SetSpeed ( 1000 );
11:
12:         //StepControl
13:         while ( true )
14:         {
15:             io.DesLED ( 1 );
16:             until.Sleep ( 100 );
17:
18:             io.DesLED ( 0 );
19:             until.Sleep ( 100 );
20:
21:             drive.StopDrive ( 0 );
22:             drive.SetTargetPos ( CalculateTargetPos ( 1 ) );
23:             drive.StartDrive ( 1 );
24:         }
25:     }
26: }
    
```

NanoJ V2

The second generation of our NanoJ programming language features two major improvements:

- The internal operating system of the new control generation ensures that the program will run with a stable timing of 1 ms with minimal jitter. The mapped objects, such as the inputs or controller sizes, are updated every millisecond and can be processed by the NanoJ program. This makes it possible to employ user programs to create solutions for dynamic applications, which until now often required firmware adjustments.
- Byte code is no longer executed in a virtual machine. Instead, real machine code is used, which accelerates execution several times over.

NanoIP

Our new motor controllers with an Ethernet interface can be comfortably configured using the browser-based NanoIP application. The motor controllers can be parameterized and started up using an Internet browser (e.g. Firefox, Chrome) without requiring additional software or plugins. Data can be read out or written to the object dictionary and configurations can be saved independently from (or in parallel to) the field bus. NanoJ programs can be uploaded and started as well.

The motor controllers integrate a webserver with which the NanoIP running in the browser exchanges data via the HTTP-based REST interface. This interface can also be used by customers to control the controller from their own applications if real-time capability is not required. In this case, the standard.

Ethernet interface is a simple alternative to the field bus interface, above all when it comes to integrating IT-oriented applications.

Via USB or the serial interface (or via a CAN converter from the manufacturers Ixat or Peak for CANopen), all motor controllers and Plug & Drive motors can be quickly and easily parameterized and tested using the two free software tools NanoPro and NanoCAN (using the example of NanoPro below):

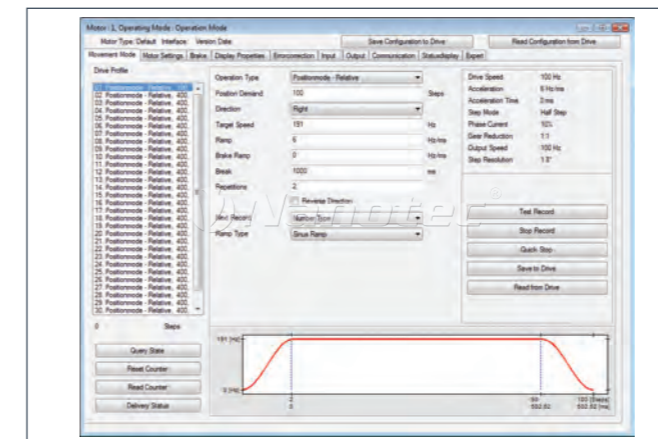

Start preset set 1 (relative positioning) with standard parameters (relative positioning, speed, ramp, etc.) in order to test whether the motor is connected properly.

Improve the motor operation for the application, e.g. speed mode with different start/target speeds, ramps and motor currents, open and closed loop.

Select the relevant operation mode for the application (e.g. absolute positioning, speed control via analog input, torque, etc.) and save the parameters to the motor controller.



The connected motor controller is identified automatically and default values can be loaded for different motors. All motor-related parameters such as max. current level, current reduction, step mode, etc. are easily configurable here.

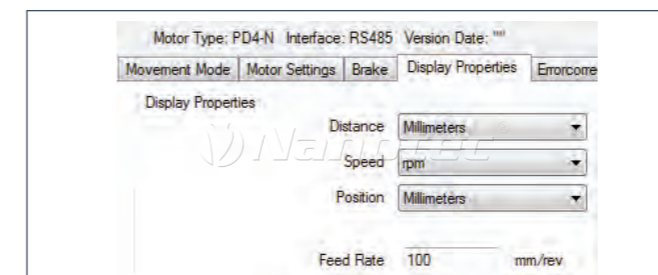

Machine settings make the parameters more transparent for the operator, thereby simplifying setup and installation. Thus, the travel and speed for a linear axis can be configured in mm and m/s and the user does not have to deal with converting to steps and Hz.



Switching states (pos./neg. signal edge) can be defined for the motor controller's digital inputs and the debouncing time for contact switches can be tested. The function of the inputs, such as release, reference switch, start, quick stop and set selection can also be set here. Even the voltage thresholds for the analog input can be configured here just like filtering and a dead zone for preventing jerking around the neutral position for joystick applications.



- A closed-loop assistant determines the necessary motor and encoder parameters for the closed loop. The load angle values are determined by an automatic calibration run.

- The control can be optimized further by autotuning and the option to adjust PID parameters manually.

- Easy switching between open-and closed-loop operation to compare operating behavior, performance, positioning times, etc.



OPTION



SOFTWARE



TECHNICAL DATA

Operating voltage	12 to 48 VDC
Phase current	Max. 2.7 A (1% increments) = 150%, 1.8 A = 100%
Interface	RS485 or CANopen
Operating type	Clock-direction, position, speed, flag position, analog, joystick CANopen: profile positioning, velocity, homing
Step frequency	Up to 1 MHz at 1/64
Inputs	6 digital inputs (5 V TTL), 1 analog input max +10 V, min -10 V adjustable
Outputs	3 open collectors, 24 V/0.5 A max.
Current reduction	Adjustable in 1% increments
Protective circuit	Overvoltage, undervoltage and temperature >80 °C, integrated ballast switching
Temperature range	-10 to +40 °C
New functions	dspDrive/easily programmable as sequential controller using NanoJ easy (RS485)

ORDER IDENTIFIER

PD2-O4118S1404-
2 = RS485 Interface
3 = CANopen Interface



ACCESSORIES

ZK-RS485-USB Converters
Z-K4700/50 Charging Capacitor
ZK-SMCI12 RS485 Cable
ZK-SMCI12-3 CANopen Cable
ZK-SMCI12-IO IO Cable



CAUTION

For stabilizing the operating voltage, we recommend using a sufficiently dimensioned decoupling capacitor.



VERSIONS

Type	Holding Torque Ncm	Weight kg	Length „A“ mm	Interface
PD2-O4118S1404	20	0.21	31	RS485, CANopen
PD2-O4118L1804	50	0.39	49	RS485, CANopen

DIMENSIONS (IN MM)

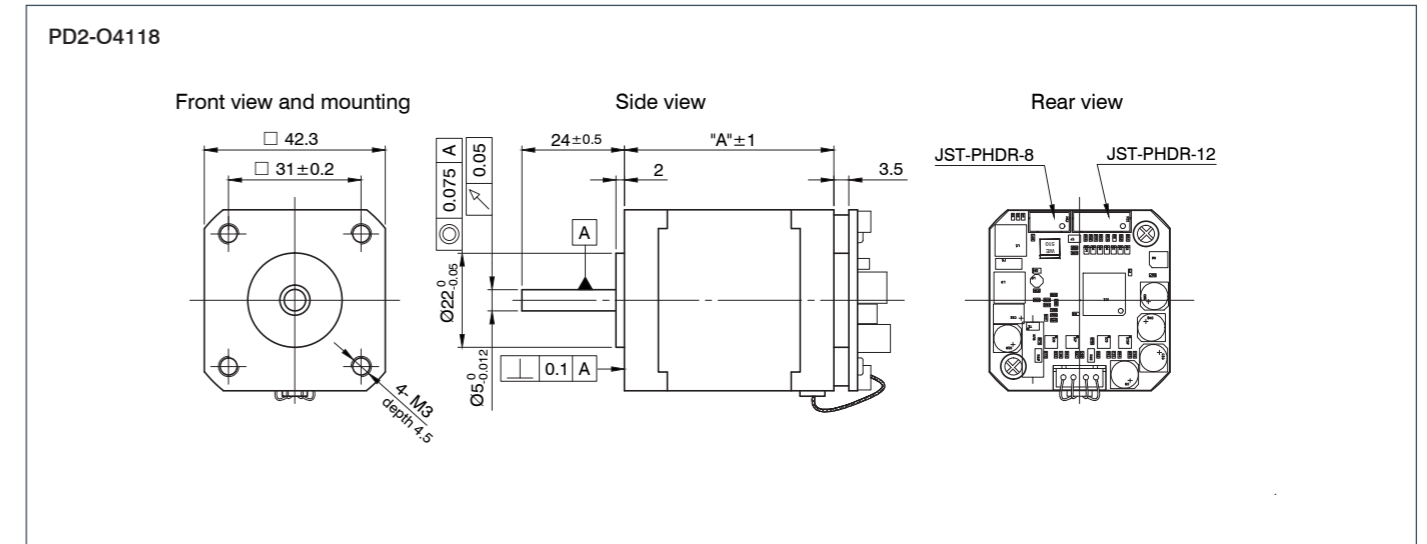

TORQUE CURVES

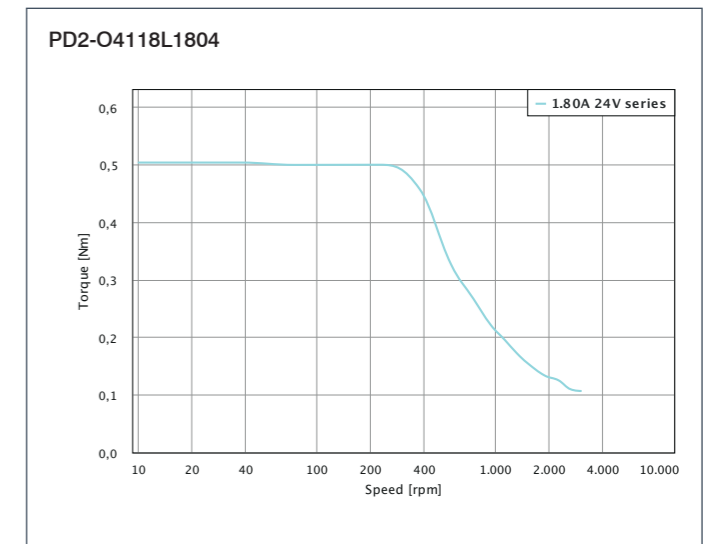
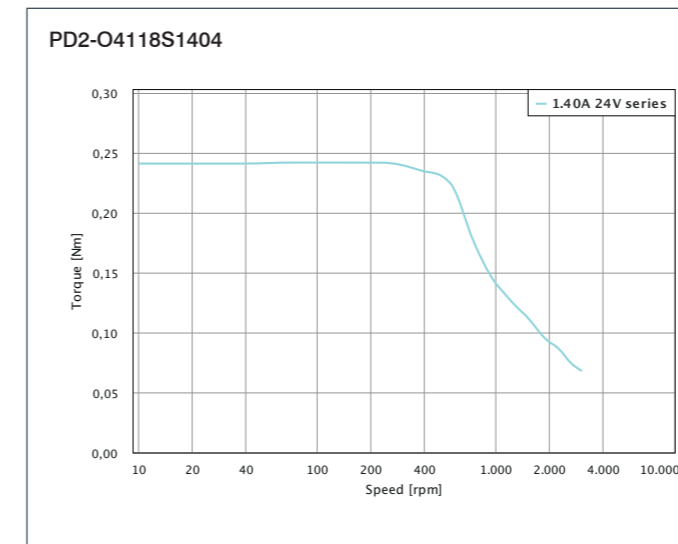



OPTION



SOFTWARE



TECHNICAL DATA

Operating voltage	12 to 48 V DC
Max. phase current	Adjustable via software up to 2.7 A (1% increments), 100% = 1.8 A
Interface	RS485 or CANopen
Operating type	RS485 interface: position, speed, reference run, flag position, clock-direction, analog and joystick, analog position, torque CANopen interface: profile position, speed, reference run, interpolated position, torque
Operating mode	1/1, 1/2, 1/4, 1/5, 1/8, 1/10, 1/16, 1/32, 1/64, adaptive microstep, feed constant
Step angle	1.8 °
Step frequency	0 to 50 kHz in clock-direction mode, 0 to 25 kHz in all other modes
Encoder	Integrated magnetic encoder, 1024 pulses/rev.
Inputs	6 digital inputs (5–24 V), 1 analog input (+10 V)
Outputs	3 outputs in open drain circuit (0 switching, max. 24 V/0.5 A)
Position monitoring	Automatic error correction up to 0.9 °
Current reduction	Adjustable in 1% increments
Protective circuit	Overvoltage and heat sink temperature >80 °C
Temperature range	-10 to +40 °C
Connection type	Plug connection with JST connectors
New functions	Closed loop/sinusoidal commutation/dspDrive/programmable as sequential controller using NanoJ easy (RS485)

ORDER IDENTIFIER

PD2-N4118L1804-
2 = RS485 Interface
3 = CANopen Interface



ACCESSORIES

ZK-PD2N Connection cable
ZK-PD2N-3 Connection cable
ZK-RS485-USB Converters
Z-K4700/50 Charging Capacitor



CAUTION

For stabilizing the operating voltage, we recommend using a sufficiently dimensioned decoupling capacitor.

VERSIONS

Type	Holding Torque Ncm	Weight kg	Length „A“ mm
PD2-N4118L1804	50	0,42	76,5

DIMENSIONS (IN MM)

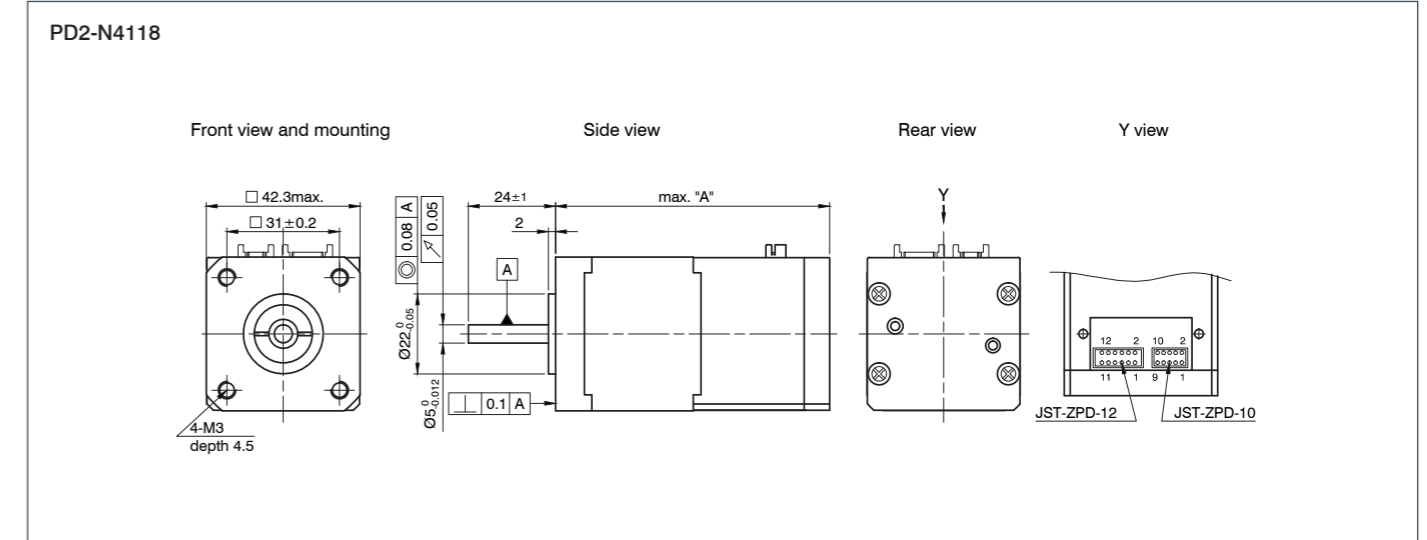

TORQUE CURVES

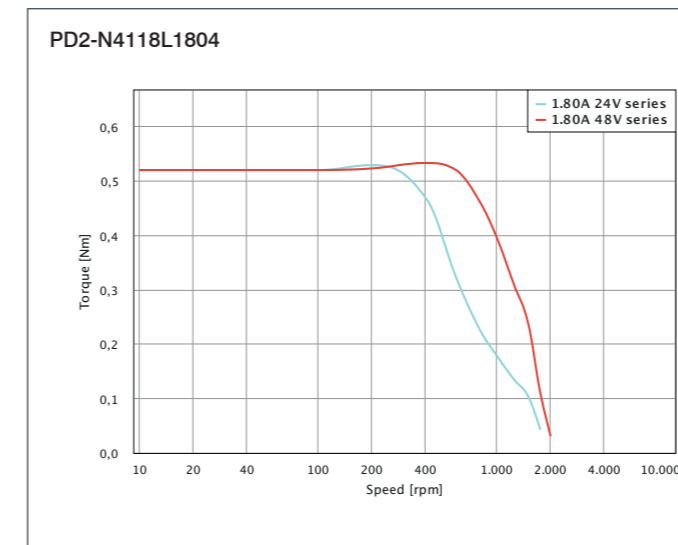

PD4-N59/N60

High-Pole Plug & Drive DC Servo Motor - NEMA 23/24



OPTION



SOFTWARE



TECHNICAL DATA

Operating voltage	12 to 48 VDC
Max. phase current	Adjustable via software up to 4.8 A (1% increments), 100% = 3.2 A
Interface	RS485 or CANopen
Operating type	Position, speed, flag position, clock-direction, analog, analog position, torque
Operating mode	1/1, 1/2, 1/4, 1/5, 1/8, 1/10, 1/32, 1/64, adaptive (1/128)
Step frequency	0 to 50 kHz in clock-direction mode, 0 to 25 kHz in all other modes
Inputs	6 opto-coupler inputs (5 – 24 V)
Outputs	Open drain (0 switching, max. 24 V/0.5 A)
Position monitoring	Automatic error correction up to 0.9 °
Current reduction	Adjustable in 1% increments
Protective circuit	Overvoltage and heat sink temperature >80 °C
Temperature range	-10 to +40 °C
Connection type	Plug connection with JST connectors
New features	Closed loop/sinusoidal commutation/dspDrive/programmable as sequential controller using NanoJ easy (RS485)

VERSIONS

Type	Holding Torque Ncm	Weight kg	Length „A“ mm
PD4-N5918X4204	53.7	0.49	66.5
PD4-N5918M4204	113	0.8	80.6
PD4-N5918L4204	198	1.22	101.6
PD4-N6018L4204	354	1.48	112.5

ORDER IDENTIFIER

PD4-N5918X4204



ACCESSORIES

ZIB-PDx-N	Additional Board
Z-K4700/50	Charging Capacitor
ZK-PD4N	Connection cable
ZK-RS485-USB	Converters



CAUTION

For stabilizing the operating voltage, we recommend using a sufficiently dimensioned decoupling capacitor.

PD4-N59/N60

High-Pole Plug & Drive DC Servo Motor - NEMA 23/24



DIMENSIONS (IN MM)

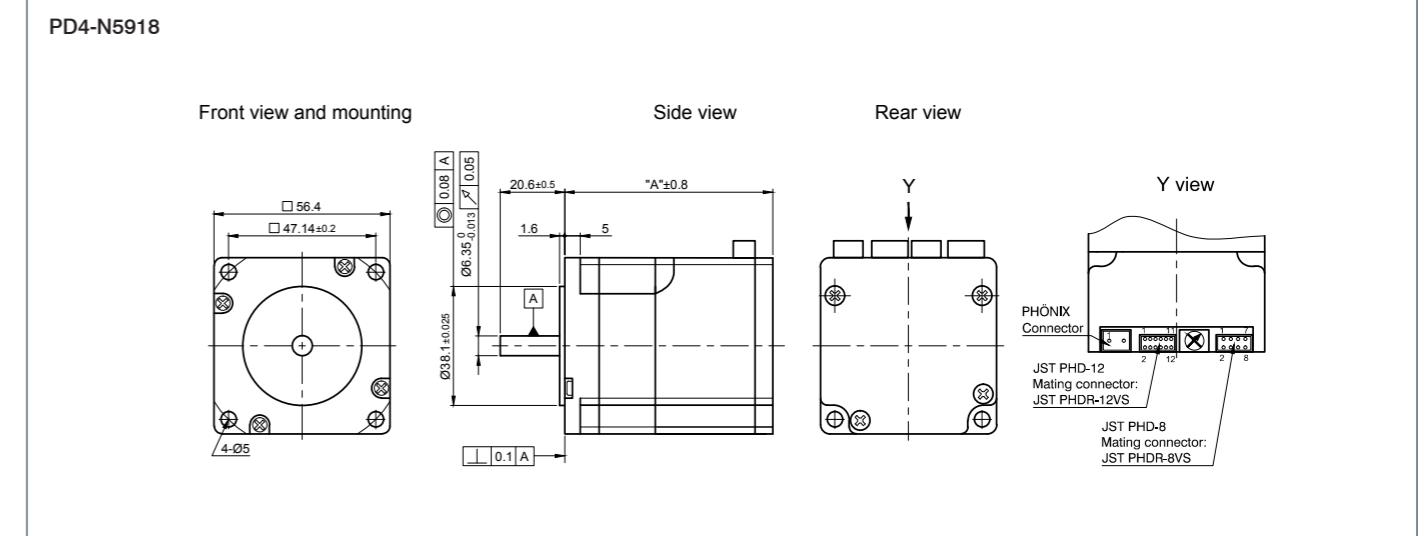

DIMENSIONS (IN MM)

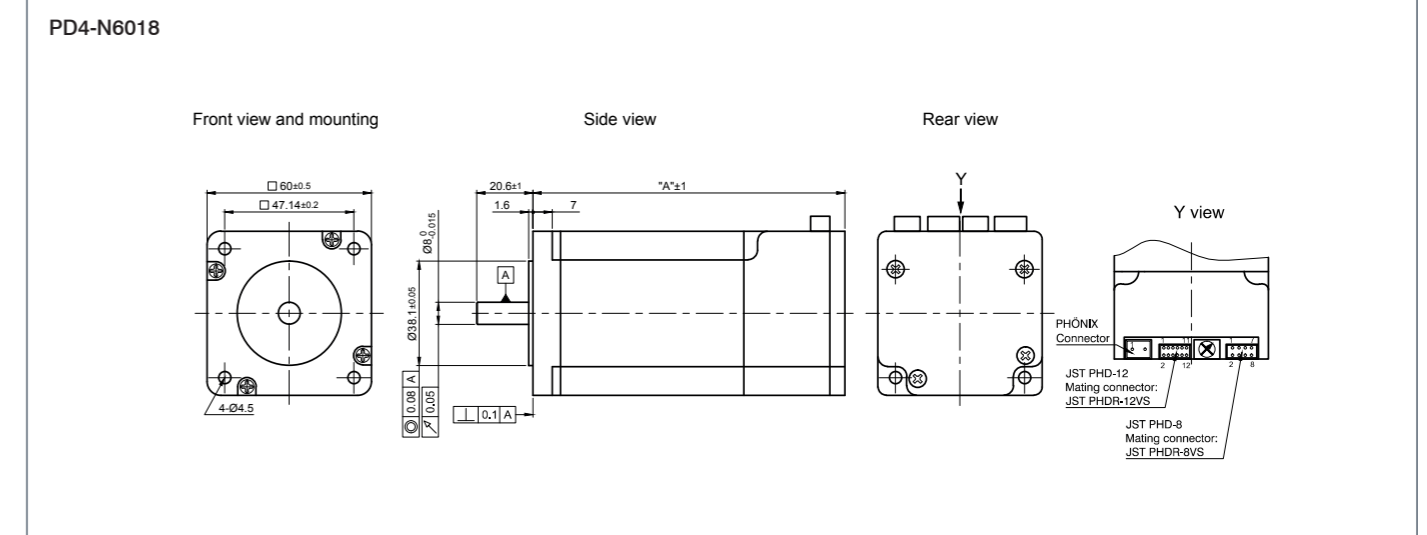



OPTION



SOFTWARE



TECHNICAL DATA

Operating voltage	12 - 48 VDC
Phase current eff.	4.2 A
RMS for 1 S	max. 6.3 A
Version	01 (USB)
Operating types	Torque, speed, position, homing
Target value specification/programming	Clock-direction, analog input/NanoJ V2, USB
Inputs	Single/differential, clock/direction/enable (+5 V/+24 V), 3 digital inputs (+24 V), 1 analog input (0-10 V)
Outputs	1 Output, max. 0.5 A, open drain
Integrated encoder	Single turn, magnetic absolute encoder, 1024 CPR
Version	08 (CAN)
Operating types	Torque, speed, position, homing
Target value specification/programming	CANopen, analog input
Inputs	4 digital inputs (+5 V / +24 V), 1 analog input (0-10 V)
Outputs	2 outputs, max. 0.5 A, open drain
Integrated encoder	Single turn, magnetic absolute encoder, 1024 CPR

ORDER IDENTIFIER

PD4-C5918M4204-E-
01 = USB Interface
08 = CANopen Interface

ACCESSORIES

Z-K4700/50 Charging Capacitor
ZK-MICROUSB USB Cable
ZK-PD4-C-CAN-4-500-S
CANopen/RS485 Cable

CAUTION

For stabilizing the operating voltage, we recommend using a sufficiently dimensioned decoupling capacitor.

VERSIONS

Type	Holding Torque Ncm	Max. Operating Voltage V	Nominal Torque Ncm	Length „A“ mm	Weight kg
PD4-C5918M4204-E	110	48	1.1	79	0.8
PD4-C5918L4204-E	198	48	1.1	100	1.2
PD4-C6018L4204-E	350	48	3.5	112.5	1.6

DIMENSIONS (IN MM)

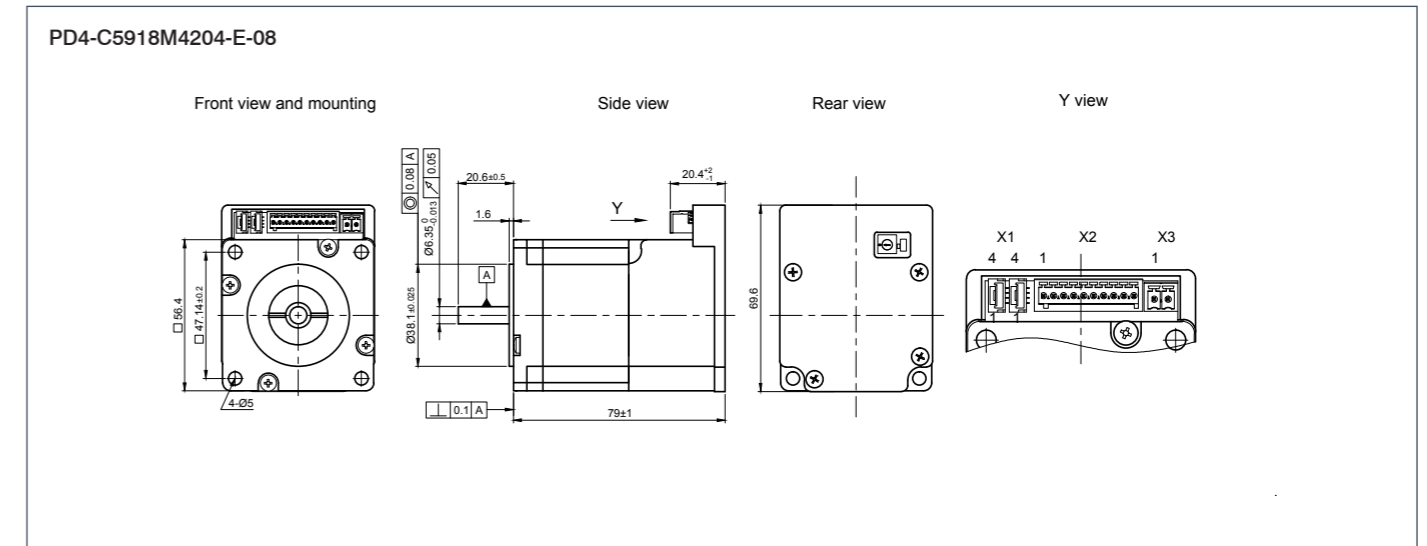
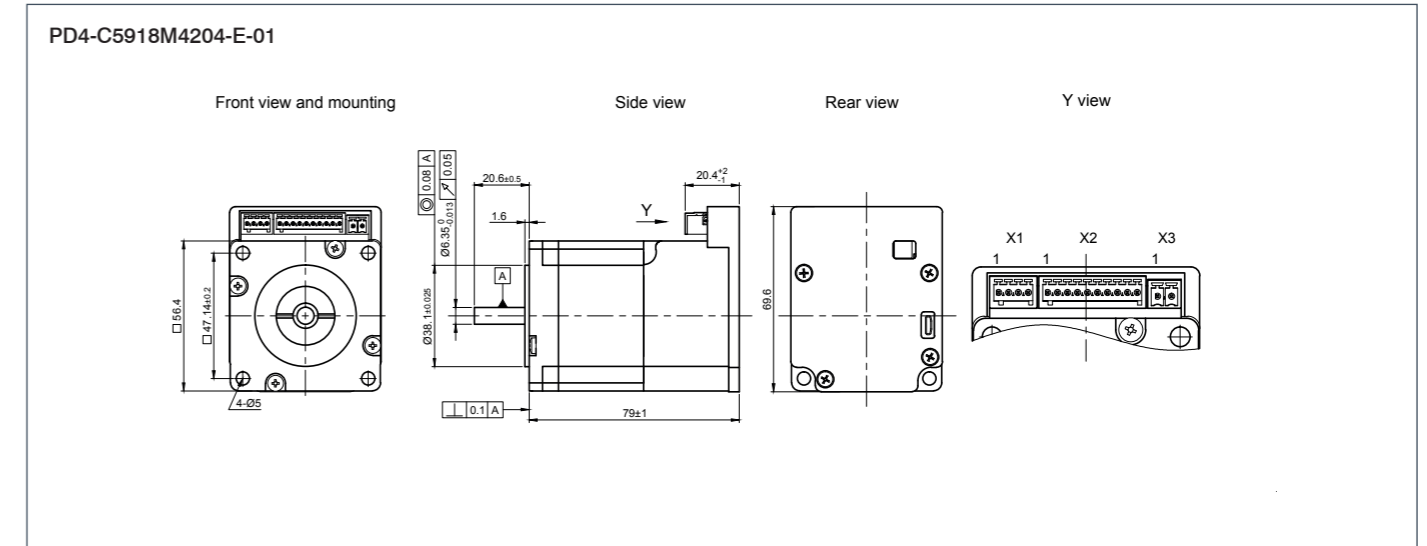

DIMENSIONS (IN MM)

PD4-C5918L4204-E-01

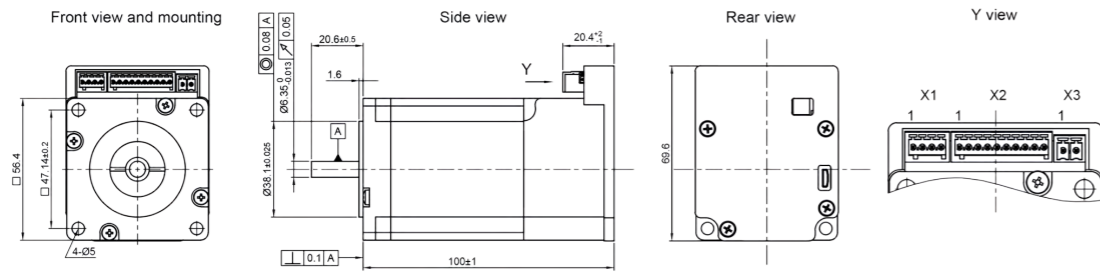

PD4-C5918L4204-E-08

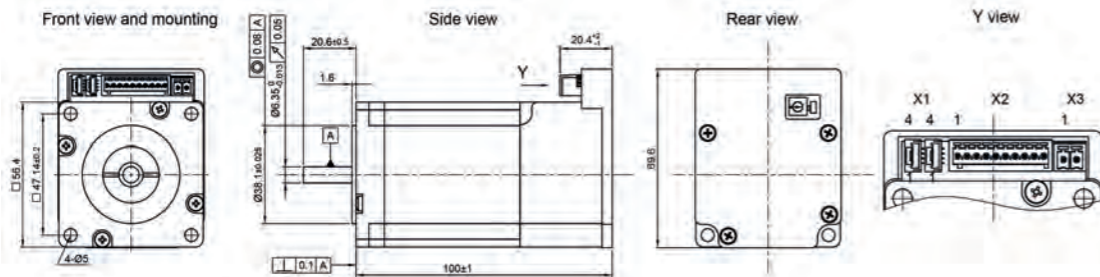

PD4-C6018L4204-E-01

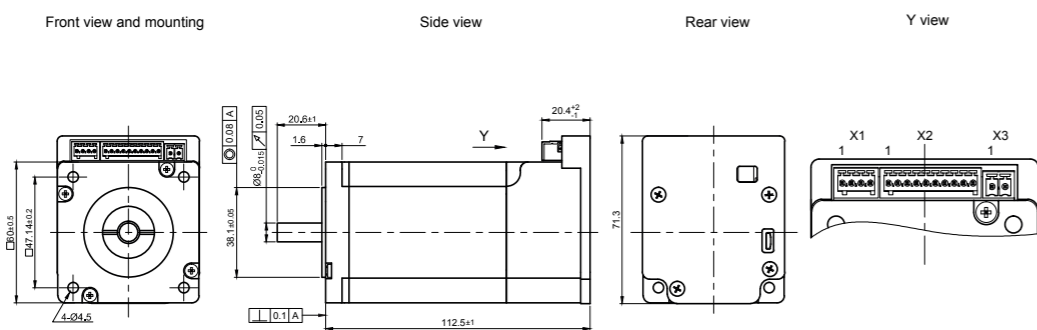

DIMENSIONS (IN MM)

PD4-C6018L4204-E-08

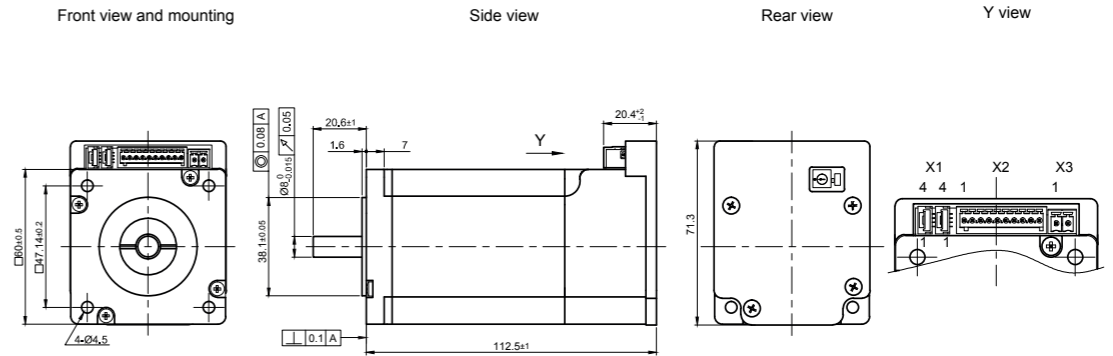



OPTION



SOFTWARE



TECHNICAL DATA

Operating voltage	12 - 24 V DC
Phase current eff.	8 A
RMS for 1 S	max. 20 A
Version	01 (USB)
Operating types	Torque, speed, position, homing
Target value specification/programming	Clock-direction, analog input, NanoJ V2, USB
Inputs	Single/differential, clock/direction/enable (+5 V/+24 V), 3 digital inputs (+24 V), 1 Analog Input (0-10 V)
Outputs	1 output, max. 0.5 A, open drain
Integrated encoder	Single turn, magnetic absolute encoder, 1024 CPR
Version	08 (CAN)
Operating types	Torque, speed, position, homing
Target value specification/programming	CANopen, analog input
Inputs	4 digital inputs (+5 V/+24 V), 1 analog input (0-10 V)
Outputs	2 outputs, max. 0.5 A, open drain
Integrated encoder	Single turn, magnetic absolute encoder, 1024 CPR

ORDER IDENTIFIER

PD4-CB59M024035-E-
 01 = USB Interface
 08 = CANopen Interface



ACCESSORIES

Z-K4700/50 Charging Capacitor
ZK-MICROUSB USB Cable
ZK-PD4-C-CAN-4-500-S
 CANopen/RS485 Cable



CAUTION

For stabilizing the operating voltage, we recommend using a sufficiently dimensioned decoupling capacitor.

VERSIONS

Type	Holding Torque Ncm	Nominal Speed rpm	Nominal Torque Ncm	Max. Operating Voltage V	Length „A“ mm	Weight kg
PD4-CB59M024035-E	37	3500	37	24	95	0.9

DIMENSIONS (IN MM)

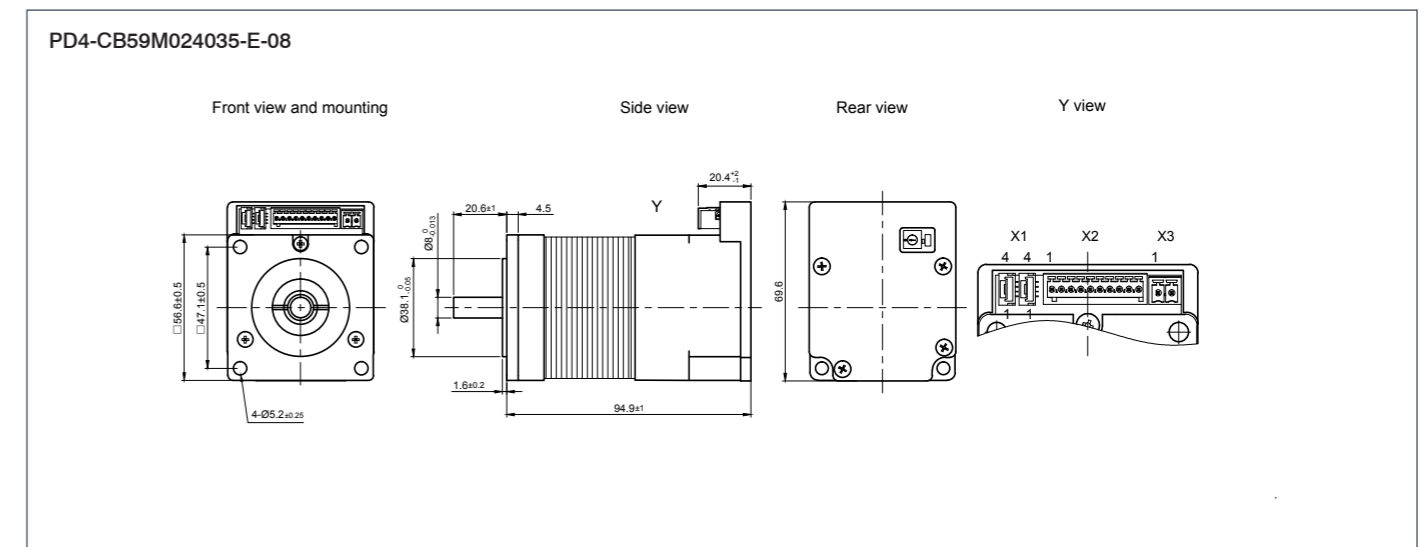
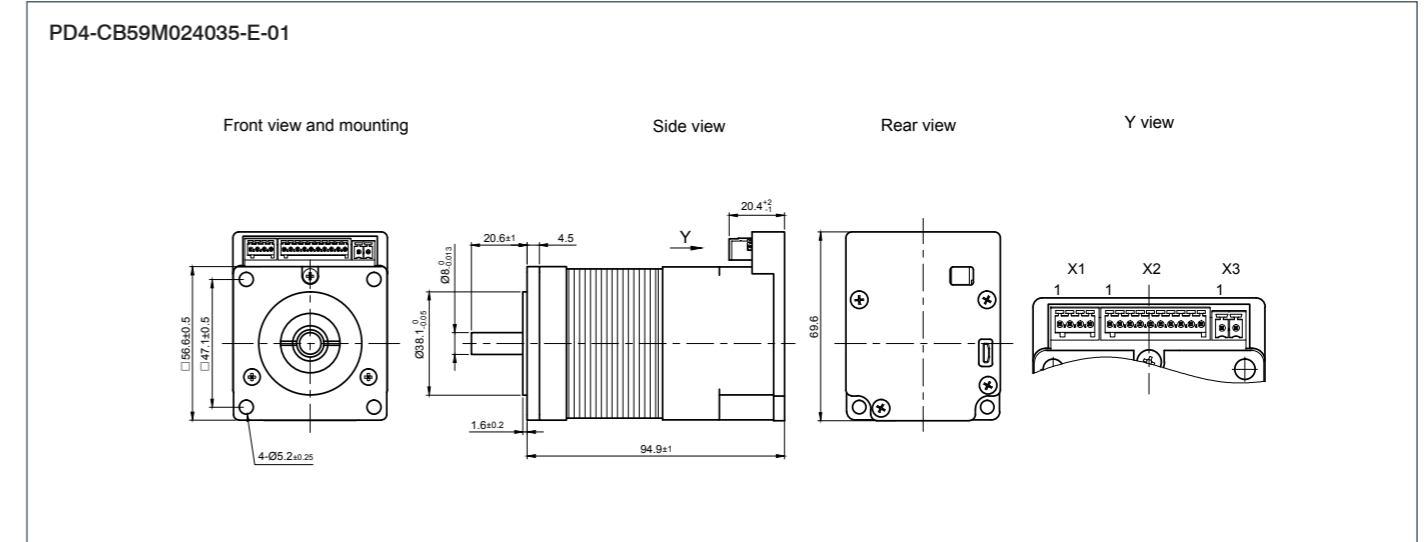

PD2-N4118-IP

High-Pole Plug & Drive DC Servo Motor in Protection
Class IP65 - NEMA 17



OPTION



SOFTWARE



TECHNICAL DATA

Operating voltage	12 to 48 VDC
Max. phase current	Adjustable via software up to 2.7 A (1% increments), 100% = 1.8 A
Interface	RS485 or CANopen
Operating type	Position, speed, flag position, clock-direction, analog, analog position, torque
Operating mode	1/1, 1/2, 1/4, 1/5, 1/8, 1/10, 1/16, 1/32, 1/64, adaptive (1/128)
Step frequency	0 to 50 kHz in clock-direction mode, 0 to 25 kHz in all other modes
Inputs	6 digital inputs (5–24 V), 1 analog input (+10 V)
Outputs	Open drain (0 switching, max. 24 V/0.5 A)
Position monitoring	Automatic error correction up to 0.9 °
Current reduction	Adjustable in 1% increments
Protective circuit	Overvoltage and heat sink temperature >80 °C
Temperature range	-10 to +40 °C
Connection type	Plug connection with 2 x M12
New functions	Closed loop/sinusoidal commutation/dspDrive/programmable as sequential controller using NanoJ easy (RS485)

VERSIONS

Type	Holding Torque Ncm	Weight kg	Length „A“ mm
PD2-N4118L1804-IP	50	0.5	76.5

ORDER IDENTIFIER

PD2-N4118L1804-IP-
2 = RS485 Interface
3 = CANopen Interface

ACCESSORIES

ZK-RS485-USB Converters
Z-K4700/50 Charging Capacitor
ZK-M12-17-1M-2-S-FIN M12 Cable
ZK-M12-17-1M-2-PUR-S M12 Cable
ZK-M12-17-3M-2-PUR-S M12 Cable

CAUTION

For stabilizing the operating voltage, we recommend using a sufficiently dimensioned decoupling capacitor.

PD2-N4118-IP

High-Pole Plug & Drive DC Servo Motor in Protection
Class IP65 - NEMA 17



DIMENSIONS (IN MM)

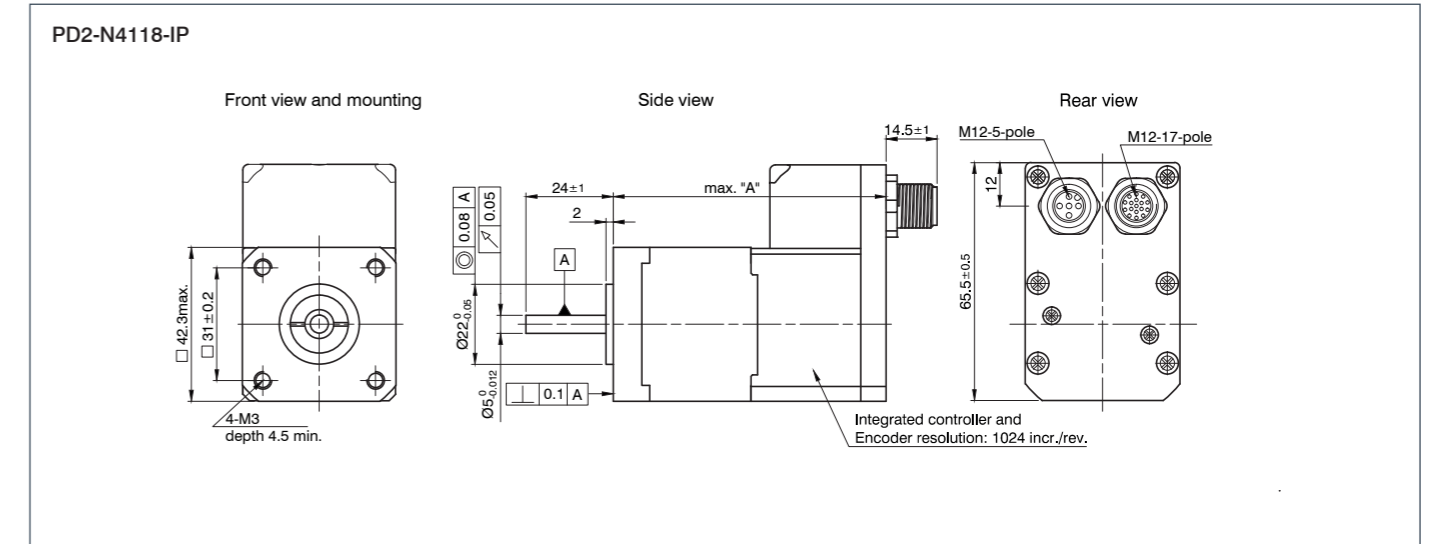

TORQUE CURVES

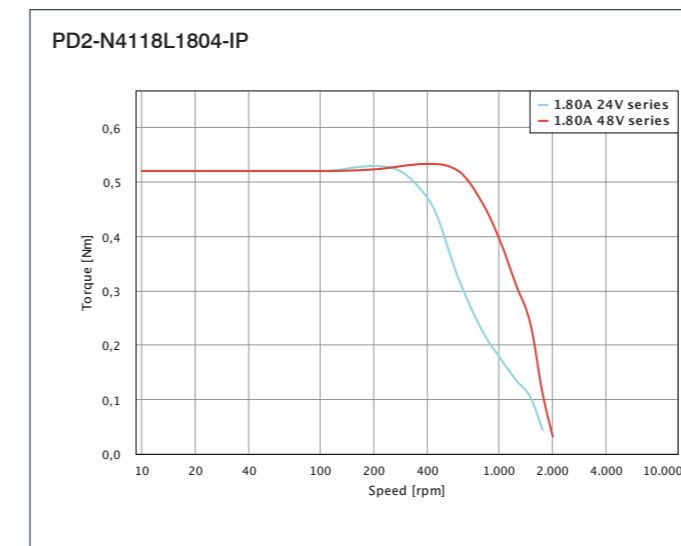

PD4-N59/N60-IP

High-Pole Plug & Drive DC Servo Motor in Protection
Class IP64 - NEMA 23/24



OPTION



SOFTWARE



TECHNICAL DATA

Operating voltage	12 to 48 VDC
Max. phase current	Adjustable via software up to 4.8 A (1% increments), 100% = 3.2 A
Interface	RS485 or CANopen
Operating type	Position, speed, flag position, clock-direction, analog, analog position, torque
Operating mode	1/1, 1/2, 1/4, 1/5, 1/8, 1/10, 1/16, 1/32, 1/64, adaptive (1/128)
Step frequency	0 to 50 kHz in clock-direction mode, 0 to 25 kHz in all other modes
Inputs	6 opto-coupler inputs (5–24 V)
Outputs	Open drain (0 switching, max. 24 V/0.5 A)
Position monitoring	Automatic error correction up to 0.9 °
Current reduction	Adjustable in 1% increments
Protective circuit	Overvoltage and heat sink temperature >80 °C
Temperature range	-10 to +40 °C
Connection type	M12
New functions	Closed loop/sinusoidal commutation/dspDrive/programmable as sequential controller using NanoJeasy (RS485)

ORDER IDENTIFIER

PD4-N5918X4204-IP-
2 = RS485 Interface
3 = CANopen Interface

ACCESSORIES

Z-K4700/50 Charging Capacitor
ZK-RS485-USB Converters
ZIB-PDx-N Additional Board

CAUTION

For stabilizing the operating voltage, we recommend using a sufficiently dimensioned decoupling capacitor.

PD4-N59/N60-IP

High-Pole Plug & Drive DC Servo Motor in Protection
Class IP64 - NEMA 23/24



VERSIONS

Type	Holding Torque Ncm	Weight kg	Length „A“ mm
PD4-N5918X4204-IP	53.7	0.49	66.5
PD4-N5918M4204-IP	113	0.8	80.6
PD4-N5918L4204-IP	198	1.22	101.6
PD4-N6018L4204-IP	354	1.48	112

DIMENSIONS (IN MM)

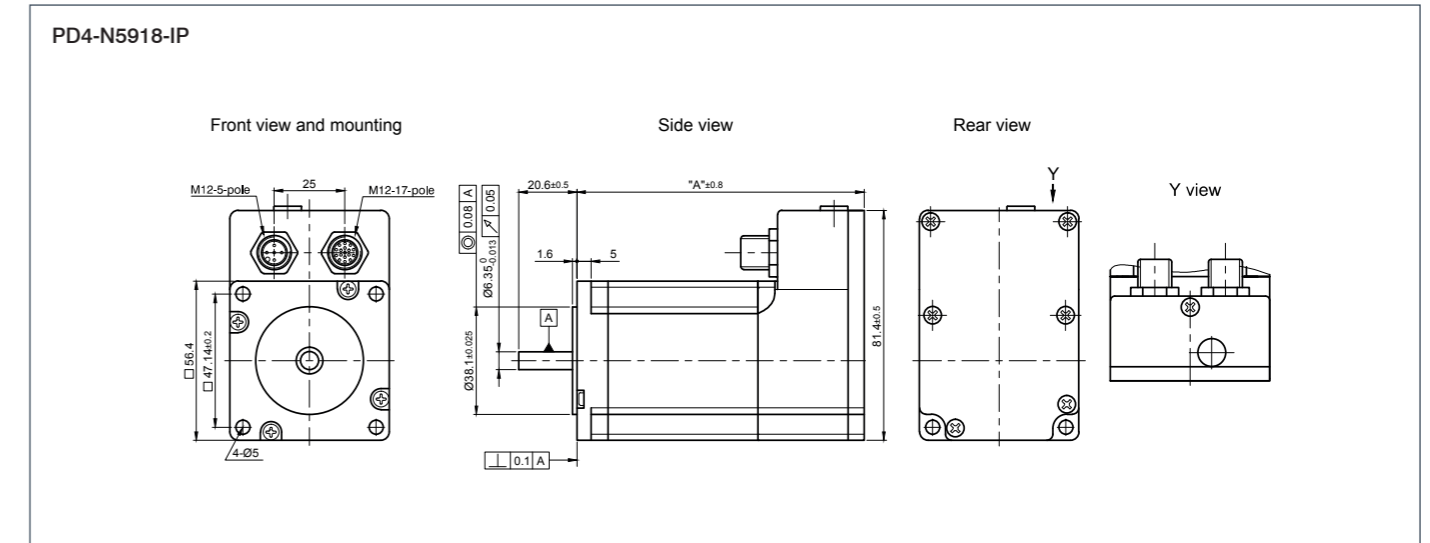

DIMENSIONS (IN MM)

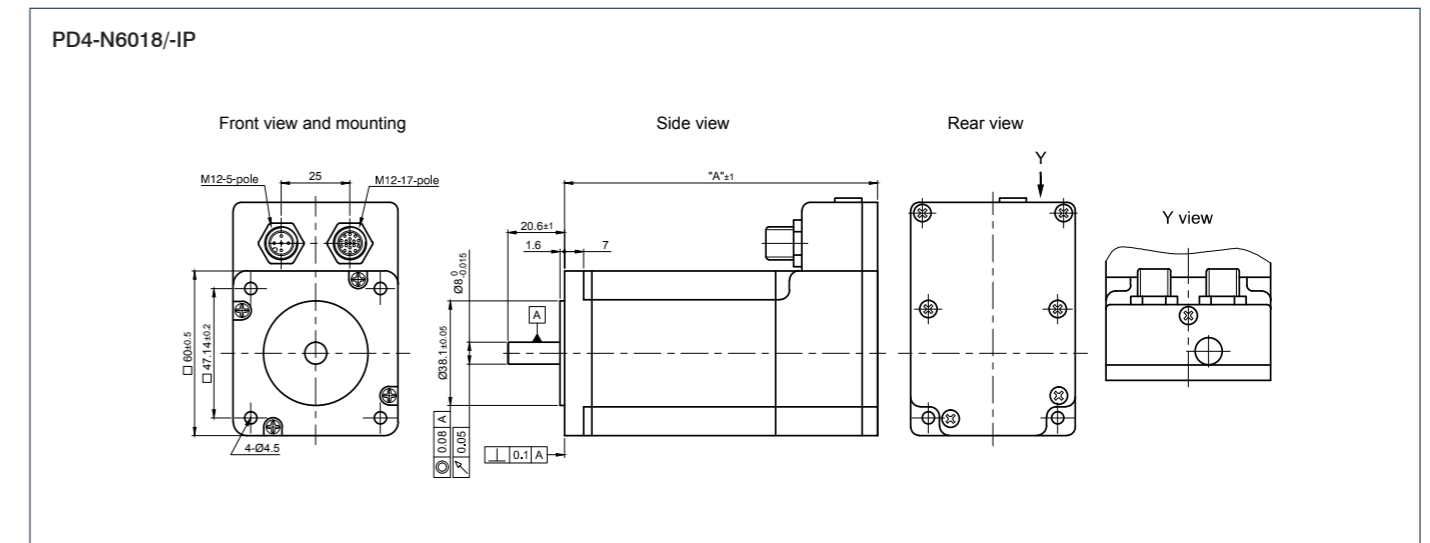

High-Pole Plug & Drive DC Servo Motor in Protection Class IP64 - NEMA 23/24

TORQUE CURVES

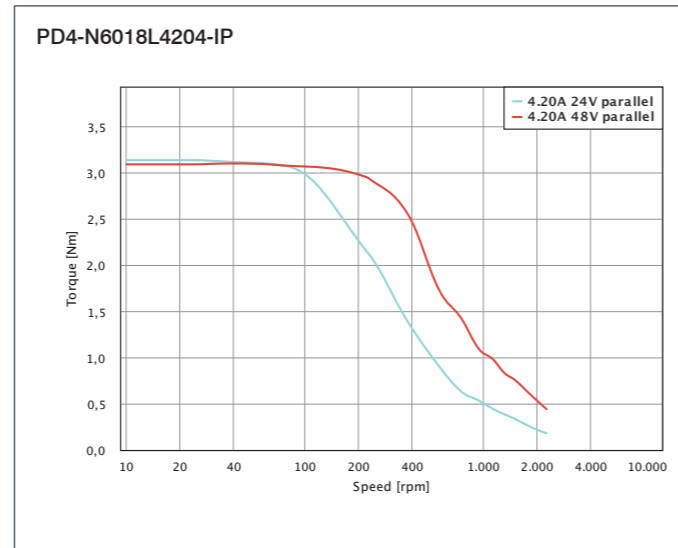
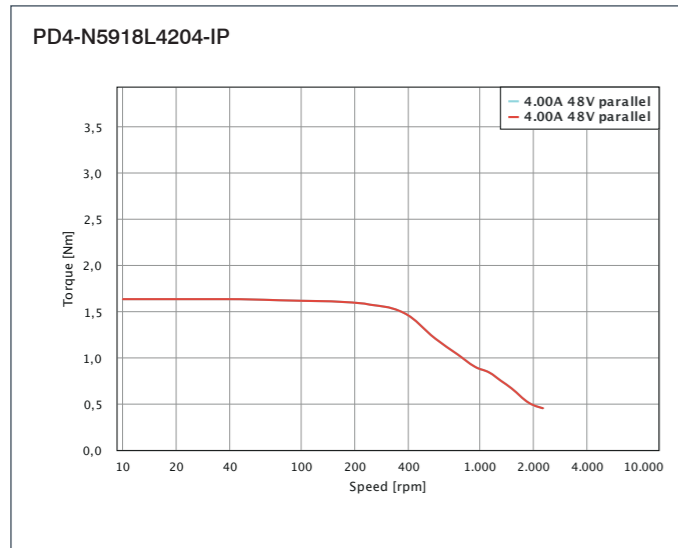
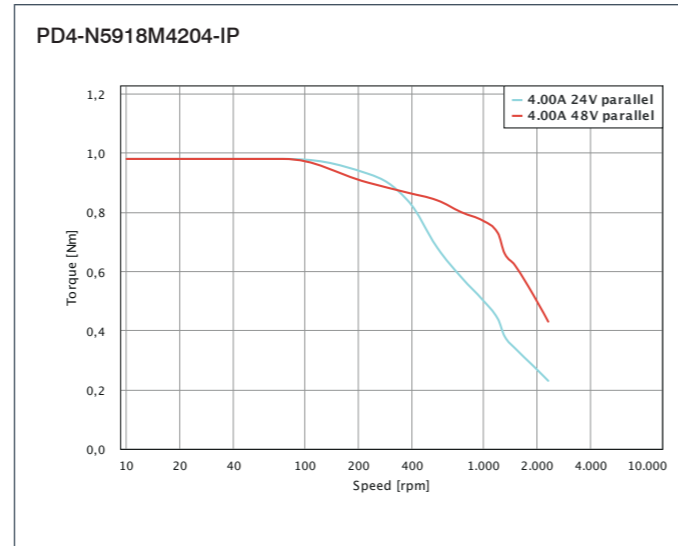
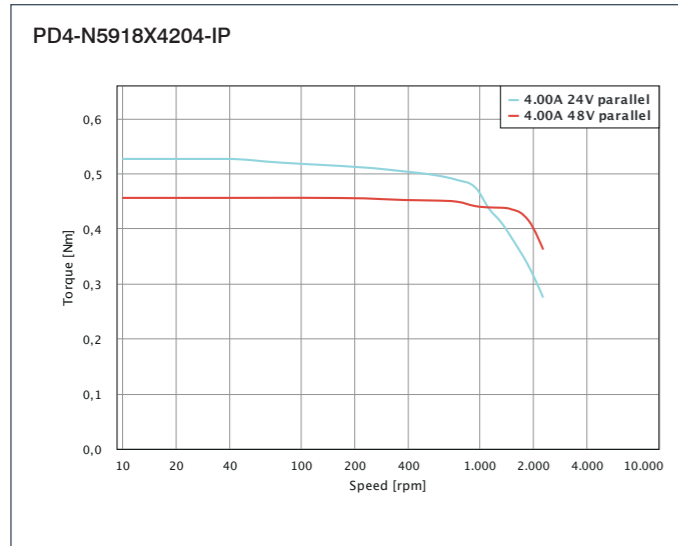

Notes section with horizontal lines for writing.



TECHNICAL DATA

Operating voltage	12 V to 35 VDC
Max. phase current	1.0 A/full step (1.25 A with cooling block), 1.4 A/microstep (1.8 A with cooling block)
Current setting	Via potentiometer
Operating type	Bipolar
Operating mode	1/1, 1/2, 1/4, 1/8 (preset)
Protection function	Overcurrent, overvoltage and over-temperature
Step frequency	0 to 200 kHz
Current reduction	Switchable to 40 %
Input signals	0 V active (L<0.8 V, 3.5 V<H<6 V or open)
Temperature range	0 to +40 °C
Connection type	JST connector
Weight	10 g
Fastening type	2 boreholes of Ø 19.05 mm for M2.5 – mounted directly on the stepper motor

VERSIONS

Type	Min. Operating Voltage V	Max. Operating Voltage V	Nominal Current A	Controller for	Interface	Weight kg
SMC11	12	35	1.4	Stepper Motors	Clock/Direction Only	0.01

ORDER IDENTIFIER

SMC11
= 1/8 Step Mode
SMC11-
2 = 1/16 Step Mode



ACCESSORIES

Z-K4700/50 Charging Capacitor
ZK-SMC11 Connection cable



CAUTION

For stabilizing the operating voltage, we recommend using a sufficiently dimensioned decoupling capacitor.



DIMENSIONS (IN MM)

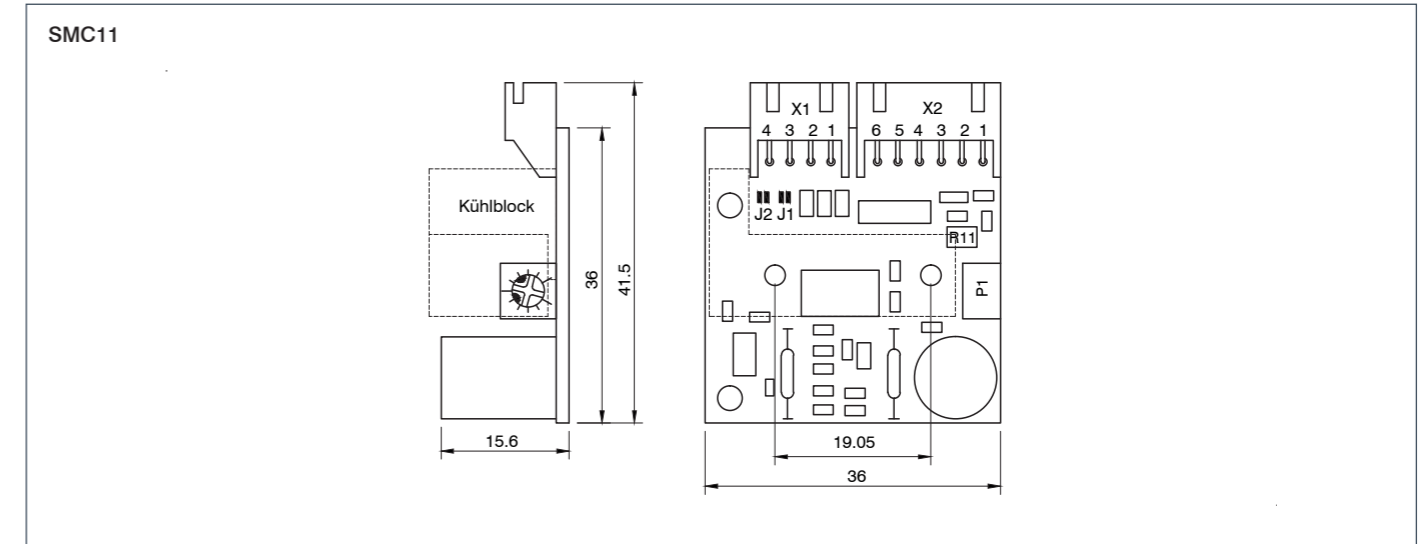



SOFTWARE



TECHNICAL DATA

Operating voltage	12 V to 24 VDC
Phase current	Nominal current 1.8 A, adjustable up to 2.7 A
Interface	RS485 4-wire or CANopen
Operating type	RS485: position, speed, flag position, clock-direction, analog, joystick CANopen: position, homing mode, velocity mode, interpolated position mode (as per CAN standard DS402)
Operating mode	1/1, 1/2, 1/4, 1/5, 1/8, 1/10, 1/32, 1/64, adaptive, feed constant
Step frequency	16 kHz in full step; in microstep corresponding multiples (e.g. up to 1 MHz at 1/64)
Inputs	6 digital inputs (TTL), 1 analog input +10/-10V
Outputs	3 open collector 24 V/0.5 A max.
Current reduction	Adjustable 0 – 100%
Protective circuit	Overvoltage, undervoltage and temperature >80 °C
Temperature range	0 to +40 °C

VERSIONS

Type	Min. Operating Voltage V	Max. Operating Voltage V	Nominal Current A	Controller for	Interface	Weight kg
SMCI12	12	24	1.8	Stepper Motors	RS485, CANopen	0.05

ORDER IDENTIFIER

SMCI12-
2 = RS485 Interface
3 = CANopen Interface



ACCESSORIES

ZK-RS485-USB Converters
Z-K4700/50 Charging Capacitor
ZK-SMCI12 RS485 Cable
ZK-SMCI12-3 CANopen Cable
ZK-SMCI12-IO IO Cable
ZK-XHP-4-300 Motor Cable



CAUTION



For stabilizing the operating voltage, we recommend using a sufficiently dimensioned decoupling capacitor.

DIMENSIONS (IN MM)

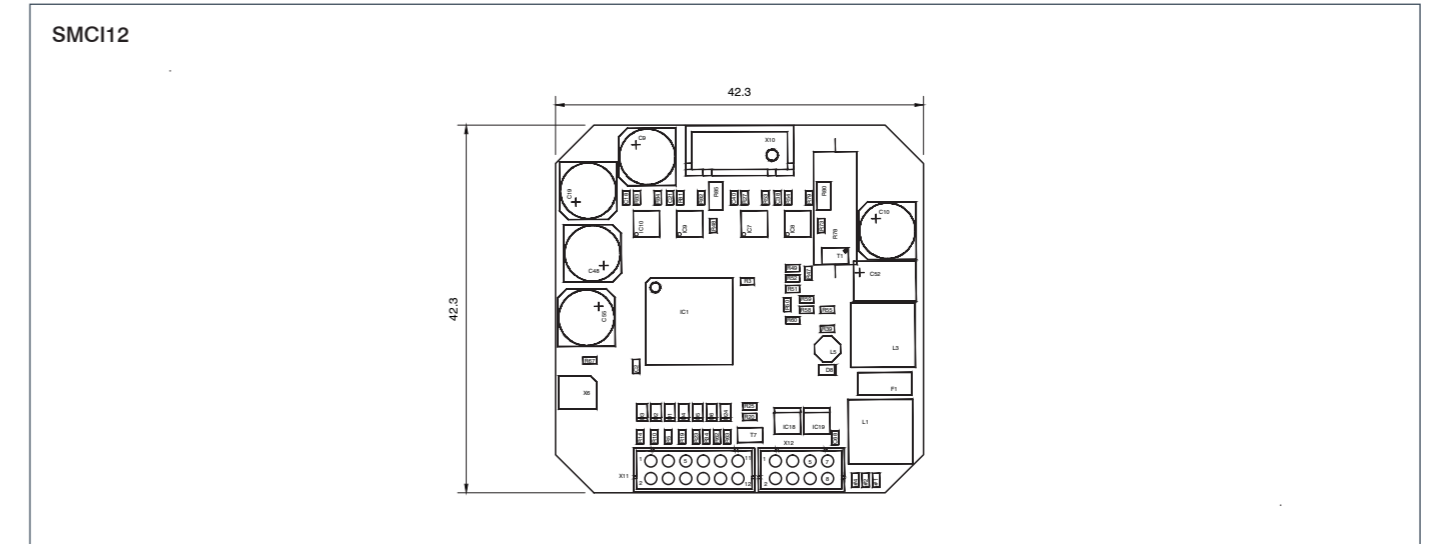



SOFTWARE



TECHNICAL DATA

Operating voltage	12 V to 48 VDC
Phase current	Nominal value 2 A (effective), with heat sink 4 A peak
Interface	RS485, USB
Operating type	Position, speed, flag position, clock-direction, analog, joystick, torque
Operating mode	1/1, 1/2, 1/4, 1/5, 1/8, 1/10, 1/32, 1/64, adaptive
Step frequency	0 to 50 kHz in clock-direction mode, 0 to 25 kHz in all other modes
Inputs	8 inputs (5 V), 2 analog inputs (-10 to +10 V)
Outputs	8 outputs (5 V, max. 20 mA TTL)
Position monitoring	Automatic error correction up to 0.9 °, only with optical encoder (e.g. WEDS5541 series)
Current reduction	Adjustable 0 – 100 %
Protective circuit	Overvoltage, undervoltage and temperature >80 °C
Temperature range	0 to +40 °C

VERSIONS

Type	Min. Operating Voltage V	Max. Operating Voltage V	Nominal Current A	Controller for	Interface	Weight kg
SMCP33	12	48	2	Stepper Motor, BLDC Motors	RS485	0.12
SMCP33-EVA	12	48	2	Stepper Motor, BLDC Motors		0.291

ORDER IDENTIFIER

SMCP33
= 2 A
SMCP33-
K= 4 A

ACCESSORIES

ZK-RS485-USB Converters
Z-K4700/50 Charging Capacitor
ZCEDA345050521202
 Mating Connector / Base
ZCEDA345220088 Board Holder
ZCEDA345240318 Encoding Element

CAUTION

For stabilizing the operating voltage, we recommend using a sufficiently dimensioned decoupling capacitor.

DIMENSIONS (IN MM)

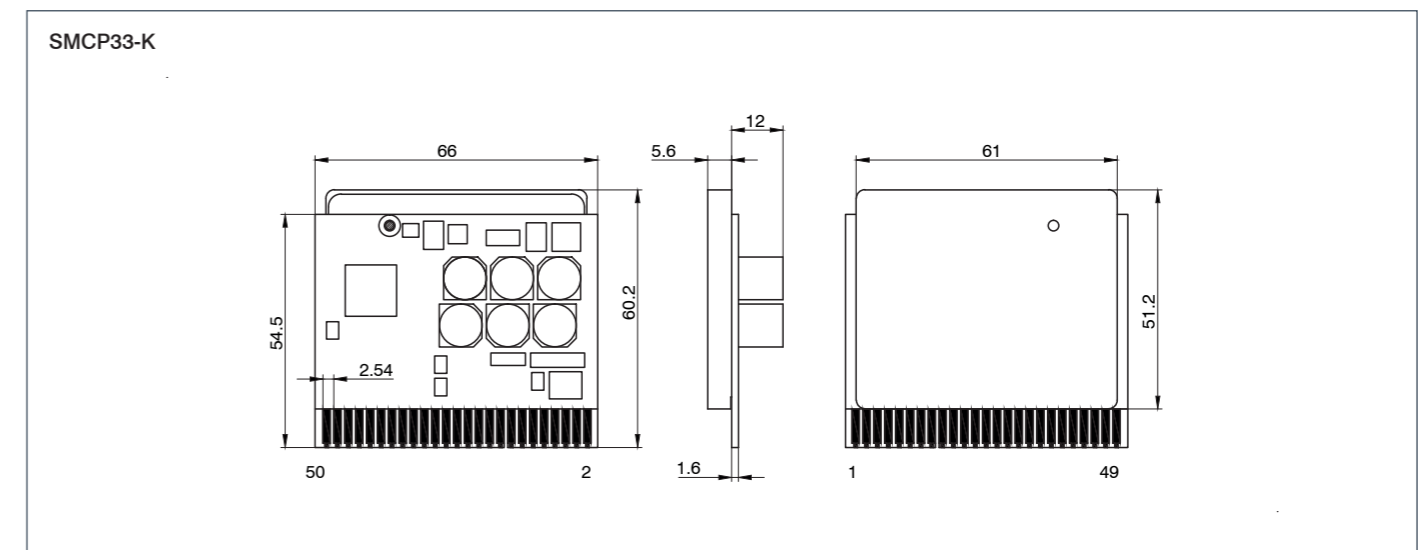
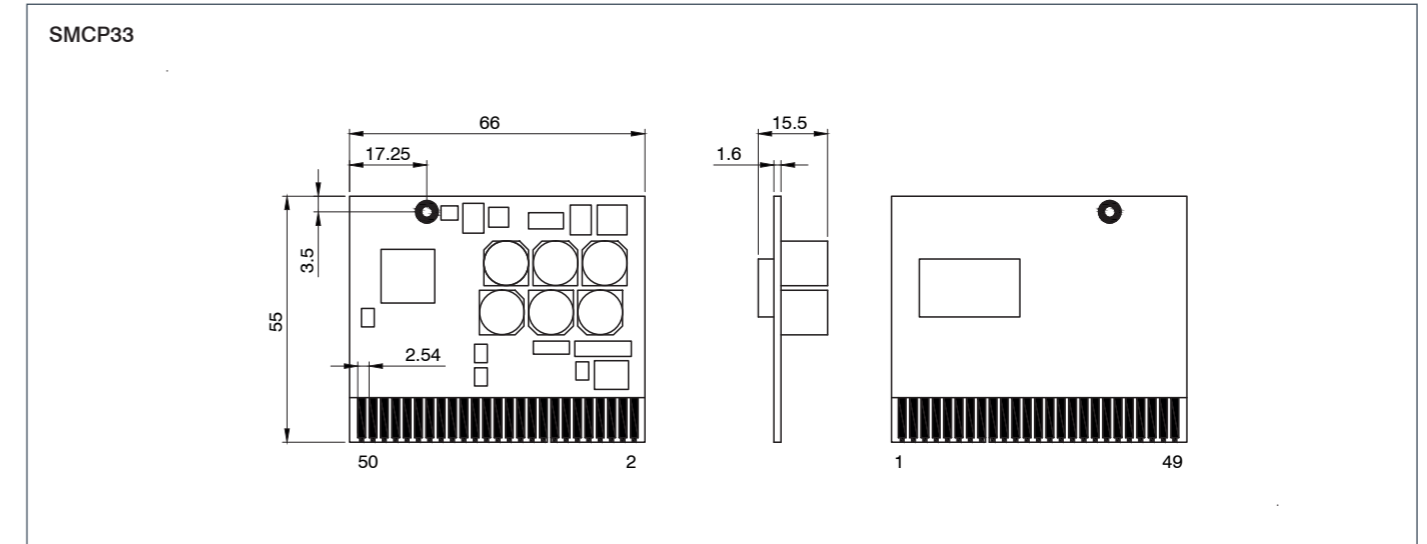



SOFTWARE



TECHNICAL DATA

Operating voltage	24 V to 48 VDC
Phase current	Nominal current 2 A, adjustable up to 3 A/phase
Interface	RS485 or USB
Operating type	Position, speed, flag position, clock-direction, analog, joystick, torque mode
Operating mode	1/1, 1/2, 1/4, 1/5, 1/8, 1/10, 1/32, 1/64, adaptive
Step frequency	0 to 50 kHz in clock-direction mode, 0 to 25 kHz in all other modes
Inputs	6 opto-coupler inputs (5 – 24 V)
Outputs	3 open collector 30 V/30 A max.
Position monitoring	Automatic error correction up to 0.9 °
Current reduction	Adjustable 0 – 100 %
Protective circuit	Overvoltage, undervoltage and temperature >80 °C
Temperature range	0 to +40 °C

VERSIONS

Type	Min. Operating Voltage V	Max. Operating Voltage V	Nominal Current A	Controller for	Interface	Weight kg
SMCI33	12	48	2	Stepper Motors	RS485, USB	0.13

ORDER IDENTIFIER

SMCI33-
1 = USB Interface
2 = RS485 Interface



ACCESSORIES

Z-K4700/50 Charging Capacitor
ZK-RS485-RS232 Converters
ZK-RS485-USB Converters
ZK-USB Connection cable
ZK-SMCI-LD Encoder Cable



CAUTION

For stabilizing the operating voltage, we recommend using a sufficiently dimensioned decoupling capacitor.

DIMENSIONS (IN MM)

SMCI33

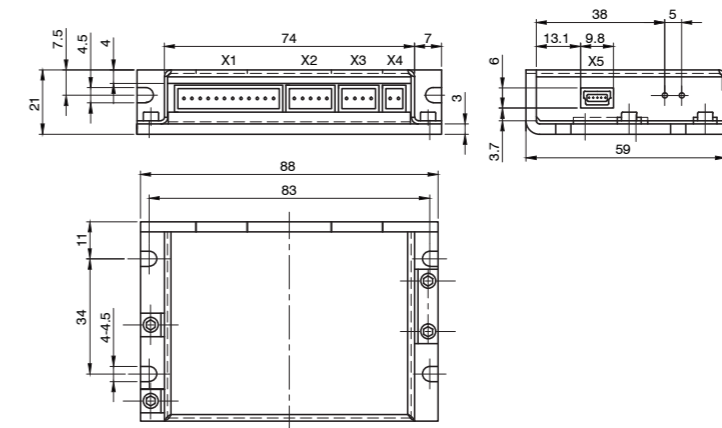



SOFTWARE



TECHNICAL DATA

Operating voltage	12 V to 48 VDC
Phase current	Max. 6 A
Interface	TTL-RS232 (3.3 V)
Operating type	Position, speed, flag position, clock-direction, analog, joystick, torque
Operating mode	1/1, 1/2, 1/4, 1/5, 1/8, 1/10, 1/32, 1/64, adaptive
Step frequency	16 kHz in full step; in microstep corresponding multiples (e.g. up to 1 MHz at 1/64)
Inputs	6 digital inputs (TTL), 1 analog input +10/-10 V
Outputs	3 digital outputs (TTL)
Position monitoring	Yes, depending on encoder
Current reduction	Adjustable 0 to 100 %
Protective circuit	Overvoltage, undervoltage and temperature >80 °C
Temperature range	0 to +40 °C

VERSIONS

Type	Min. Operating Voltage V	Max. Operating Voltage V	Nominal Current A	Controller for	Interface	Weight kg
SMCI35	12	48	4	Stepper Motors	RS232 (3.3 V)	0.9

ORDER IDENTIFIER

SMCI35

ACCESSORIES

- ZK-RS232-USB-3.3V** Converters
- Z-K4700/50** Charging Capacitor
- ZK-WEDS-300-S-SMCI35** Encoder Cable
- ZK-ZHR5-90** Connection cable
- ZK-ZHR6-500** Connection cable
- ZK-SMCI35-LD** Encoder Cable

CAUTION

For stabilizing the operating voltage, we recommend using a sufficiently dimensioned decoupling capacitor.

DIMENSIONS (IN MM)

SMCI35

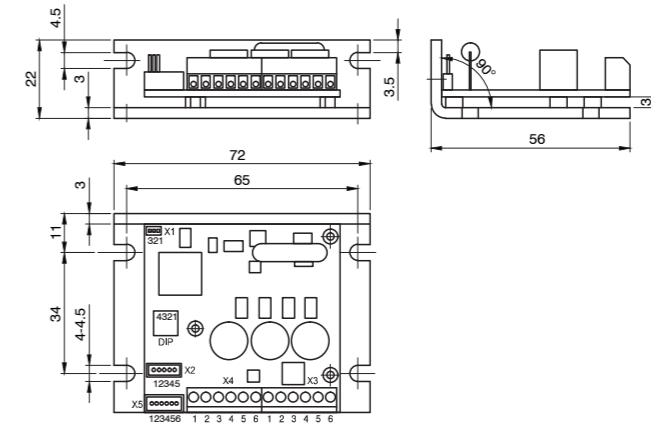



SOFTWARE



TECHNICAL DATA

Operating voltage	12 V to 72 VDC
Phase current	Nominal current 6 A, max. 9 A (eff)
Interface	RS485 4-wire or CANopen
Operating type	RS485: position, speed, flag position, clock-direction, analog, joystick CANopen: position, homing mode, velocity mode, interpolated position mode (as per CAN standard DS402), torque mode
Operating mode	1/1, 1/2, 1/4, 1/5, 1/8, 1/10, 1/32, 1/64, adaptive microstep, feed constant
Step frequency	16 kHz in full step; in microstep corresponding multiples (e.g. up to 1 MHz at 1/64)
Inputs	6 digital inputs (TTL), 1 analog input +10/-10 V
Outputs	3 digital outputs (open drain)
Position monitoring	Yes, depending on encoder
Current reduction	Adjustable 0 – 100 %
Protective circuit	Overvoltage, undervoltage and heatsink temperature >75 °C
Temperature range	0 to +40 °C

VERSIONS

Type	Min. Operating Voltage V	Max. Operating Voltage V	Nominal Current A	Controller for	Interface	Weight kg
SMCI36	12	72	6	Stepper Motor, BLDC Motors	RS485 or CANopen	0.11
SMCI36-L	12	72	2.2	Stepper Motor, BLDC Motors	RS485 or CANopen	0.11

ORDER IDENTIFIER

SMCI36
= RS485 Interface
SMCI36-
3=CANopen Interface

ACCESSORIES

ZK-RS485-USB Converters
Z-K10000/100 Charging Capacitor
ZK-WEDS-300-S-SMCI35 Encoder Cable
ZK-ZHR5-90 Connection cable
ZK-ZHR6-500 Connection cable
ZK-SMCI35-LD Encoder Cable

CAUTION

For stabilizing the operating voltage, we recommend using a sufficiently dimensioned decoupling capacitor.

DIMENSIONS (IN MM)

SMCI36

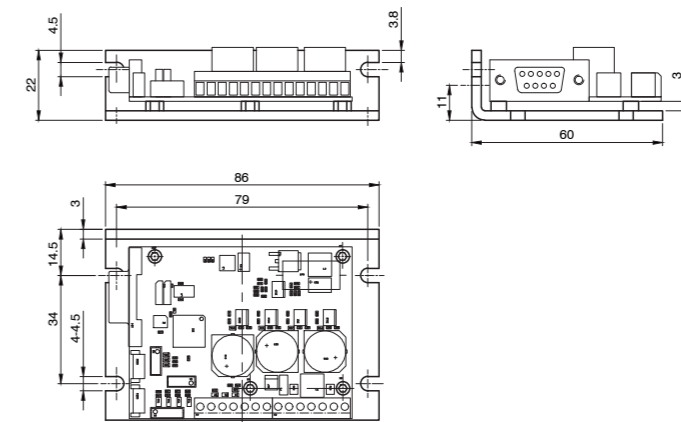



SOFTWARE



TECHNICAL DATA

Operating voltage	24 V to 48 VDC
Phase current	Nominal current 7.0 A, adjustable up to 10.5 A/phase
Interface	RS485 or CANopen
Operating type	RS485: position, speed, flag position, clock-direction, analog, joystick CANopen: position, homing mode, velocity mode, interpolated position mode, torque mode
Operating mode	1/1, 1/2, 1/4, 1/5, 1/8, 1/10, 1/32, 1/64, adaptive
Step frequency	0 to 50 kHz in clock-direction mode, 0 to 25 kHz in all other modes
Inputs	6 opto-coupler inputs (5 to 24 V)
Outputs	3 open collector, 30 V/2 A max., 1 output for brake, max. 1.5 A
Position monitoring	Automatic error correction up to 0.9 °
Current reduction	Adjustable 0 – 100%
Protective circuit	Overvoltage, undervoltage and heat sink temperature >80 °C
Temperature range	0 to +40 °C

VERSIONS

Type	Min. Operating Voltage V	Max. Operating Voltage V	Nominal Current A	Controller for	Interface	Weight kg
SMCI47-S	12	48	7	Stepper Motors	RS485, CANopen	0.15

ORDER IDENTIFIER

SMCI47-S-
2 = RS485 Interface
3 = CANopen Interface

ACCESSORIES

Z-K4700/50 Charging Capacitor
ZK-RS485-RS232 Converters
ZK-RS485-USB Converters
ZK-SMCI-LD Encoder Cable

CAUTION

For stabilizing the operating voltage, we recommend using a sufficiently dimensioned decoupling capacitor.

DIMENSIONS (IN MM)

SMCI47-S

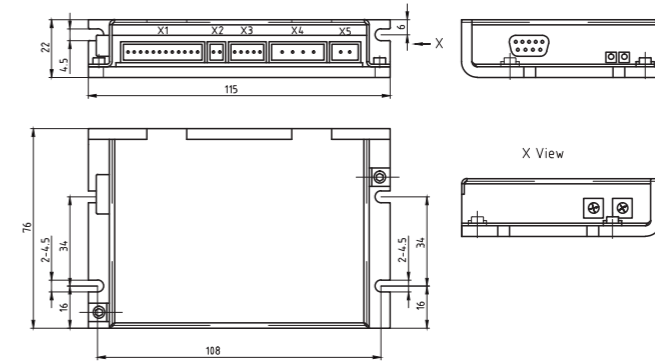



SOFTWARE



TECHNICAL DATA

Operating voltage	12-48 VDC +/-4 %
Max. continuous current	6 A (eff)
Peak current	10 A (eff. for 1 s)
Commutation	Open-loop stepper motor, closed-loop stepper motor with encoder, BLDC with sinusoidal commutation via hall sensor, BLDC with sinusoidal commutation via encoder
Operating mode	Profile position mode, profile velocity mode, profile torque mode, velocity mode, homing mode, cyclic sync position mode, cyclic sync velocity mode, cyclic sync torque mode, clock/direction mode, application program (NanoJ)
Interfaces	2xSPI, 1xI2C or CAN (external circuit required!)
Encoder/hall	2x encoder interface and 1x hall sensor interface (external circuit required!)
I/O	7x general I/O, 2x AD converter, 1x output for external brake
Connector	PCI Express 8x, 1.0 mm RM, 2x49 contacts
Current reduction	Adjustable from 0 to 100%
Protective circuit	Overtemperature protection at temperatures >70 °C, polarity reversal protection through PIN diode (short circuit between +VB and GND)

VERSIONS

Type	Min. Operating Voltage V	Max. Operating Voltage V	Peak Current A	Controller for	Interface	Weight kg
NP5	12	48	10	Stepper Motor, BLDC Motors	CANopen, SPI	0.05

DIMENSIONS (IN MM)

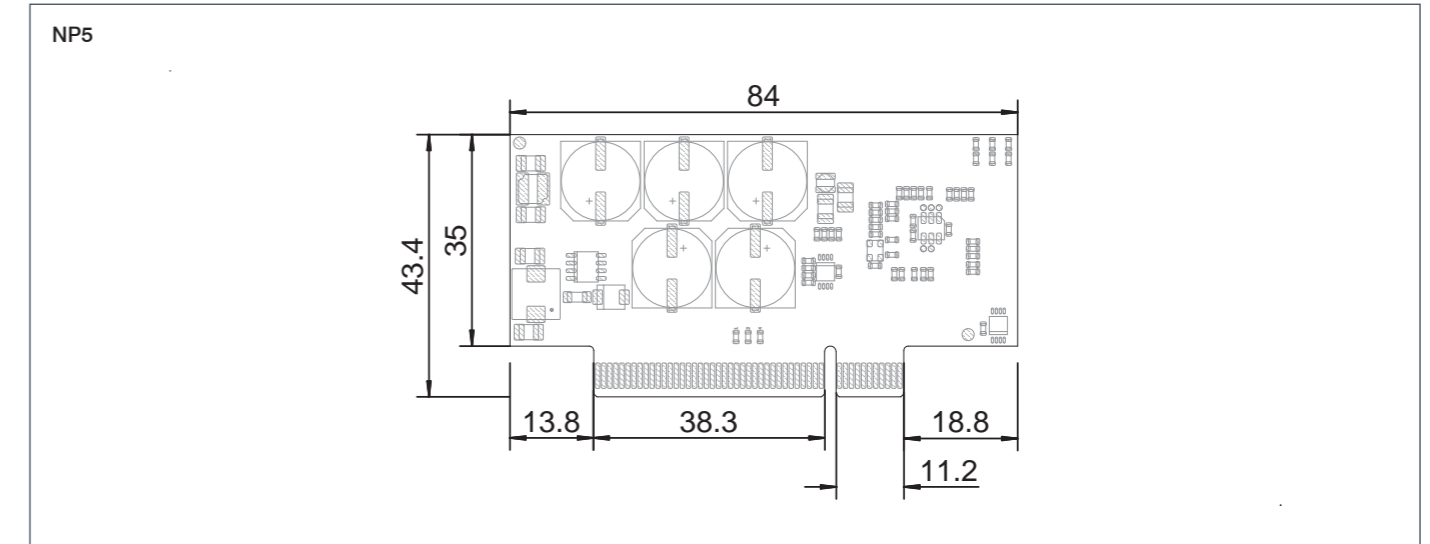



SOFTWARE

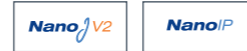

TECHNICAL DATA

Operating voltage	12-48 VDC (low-current version), or 12-48 V DC (high-current version)
Continuous current	10 A eff. (low-current version), or 18 A eff. (high-current version)
Peak current	10 A effective (low current version), or 54 A effective (high current version)
Commutation	Open-loop stepper motor, closed-loop stepper motor with encoder, BLDC with sinusoidal commutation via hall sensor, BLDC with sinusoidal commutation via encoder
Operating mode	Profile position mode, velocity mode, homing mode, cyclic syncposition mode, cyclic sync velocity mode, cyclic sync torque mode, clock/direction mode, application program (NanoJ)
Parameter setting	Browser-based via Ethernet with the NanoIP interface
Field-bus interfaces	EtherCAT or CANopen
Encoder input	5 V or 24 V signal, differential or single-ended, max. resolution 65536 CPR (16 bit), UVW connection for hall sensor
Inputs	4 inputs 5 V/24 V switchable in software (inputs 1 to 4); 2 inputs, wide range, 5-24 V (inputs 5 and 6); 2 analog inputs -10 to +10 V or 0-20 mA (switchable in software)
Outputs	2 transistor outputs, (open drain, 0 switching, max. 24 V/0.5 A)
Brake	1 open-drain output, max. 1.5 A
Protective circuit	Overvoltage and undervoltage, overtemperature: protective circuit at temperature >70 °C polarity reversal protection: in case of polarity reversal, short circuit between supply voltage and GND via PIN diode, therefore cable protection device (fuse) required in supply cable.

VERSIONS

Type	Min. Operating Voltage V	Max. Operating Voltage V	Nominal Current A	Controller for	Interface	Weight kg
N5-1	12	48	10	Stepper Motor, BLDC Motors	EtherCAT, CANopen	0.2
N5-2	12	48	18	Stepper Motor, BLDC Motors	EtherCAT, CANopen	0.2

ORDER IDENTIFIER

N5-1-
1 = EtherCAT Interface
2 = CANopen Interface



ACCESSORIES

ZK-M12-8-2M-2-PADP M12 Cable
ZK-M12-12-2M-2-PADP M12 Cable
ZK-NOE-10-500-S-PADP Encoder Cable
ZK-PADP-12-500-S Encoder Cable



CAUTION



For stabilizing the operating voltage, we recommend using a sufficiently dimensioned decoupling capacitor.

DIMENSIONS (IN MM)

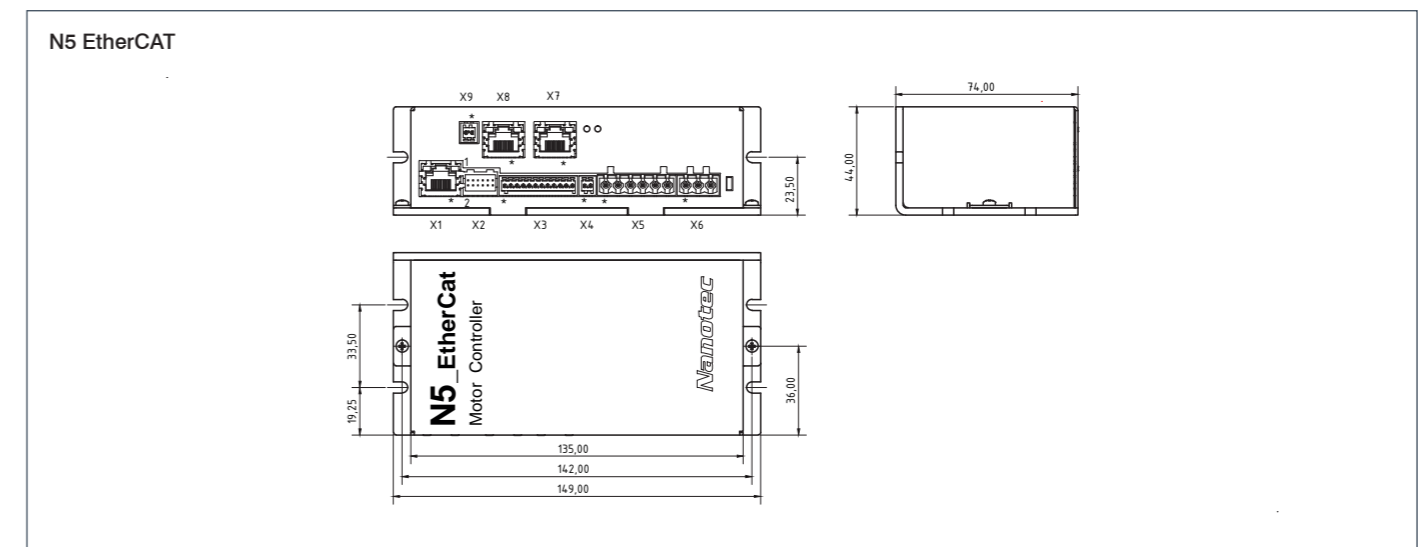
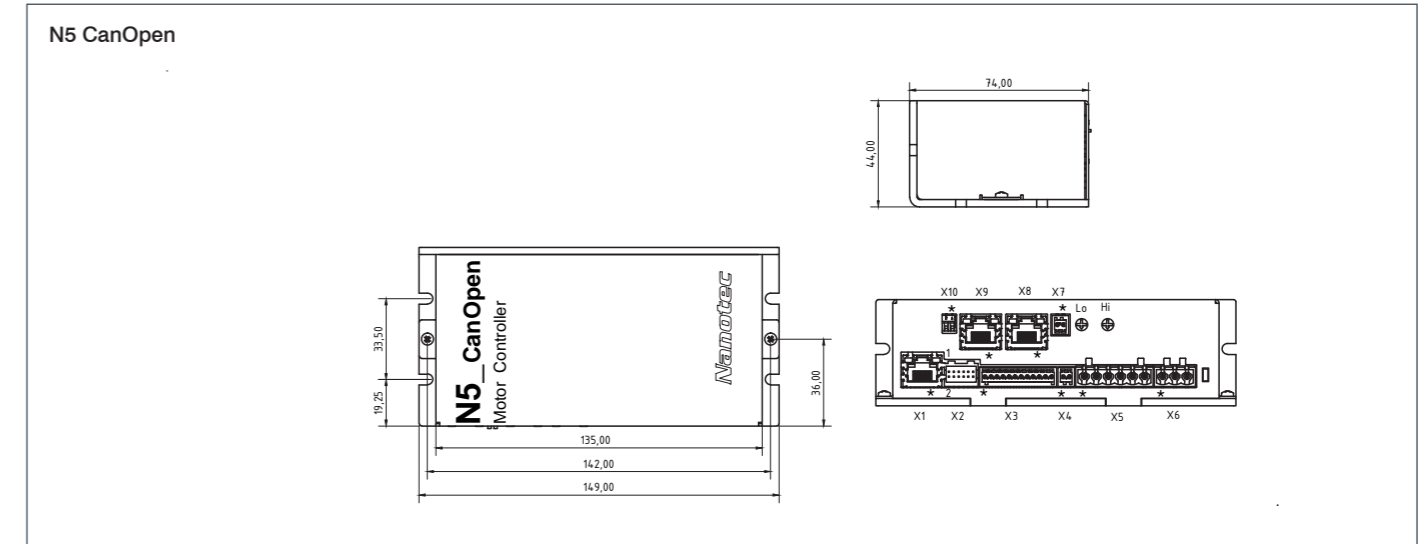



SOFTWARE



TECHNICAL DATA

Operating voltage	12-48 VDC +/- 5%
Max. current (RMS)	6 A
Operating modes	Torque, speed, position, homing
Setpoint setting/programming	Clock-direction/analog/NanoJ
Digital inputs	3 Digital inputs, 24 V, 3 digital inputs switchable 5/24 V, single ended (inverted inputs not used) or differential
Analog inputs	1 analog input, switchable 0-10 V/0-20 mA
Digital outputs	2 digital outputs, open drain, 24 V/100 mA
DIP switch	1 DIP switch with 4 poles
Status LED	Bicolor red/green
Dimensions	88x56x22 mm
Protective function	Overtemperature, overvoltage (balance circuit), inverse polarity (needs fuse in supply cable)

VERSIONS

Type	Min. Operating Voltage V	Max. Operating Voltage V	Nominal Current A	Controller for	Interface	Weight kg
C5-01	12	48	6	Stepper Motors	USB	0.13

ORDER IDENTIFIER

C5-01



ACCESSORIES

ZK-MICROUSB USB Cable



CAUTION

For stabilizing the operating voltage, we recommend using a sufficiently dimensioned decoupling capacitor.

DIMENSIONS (IN MM)

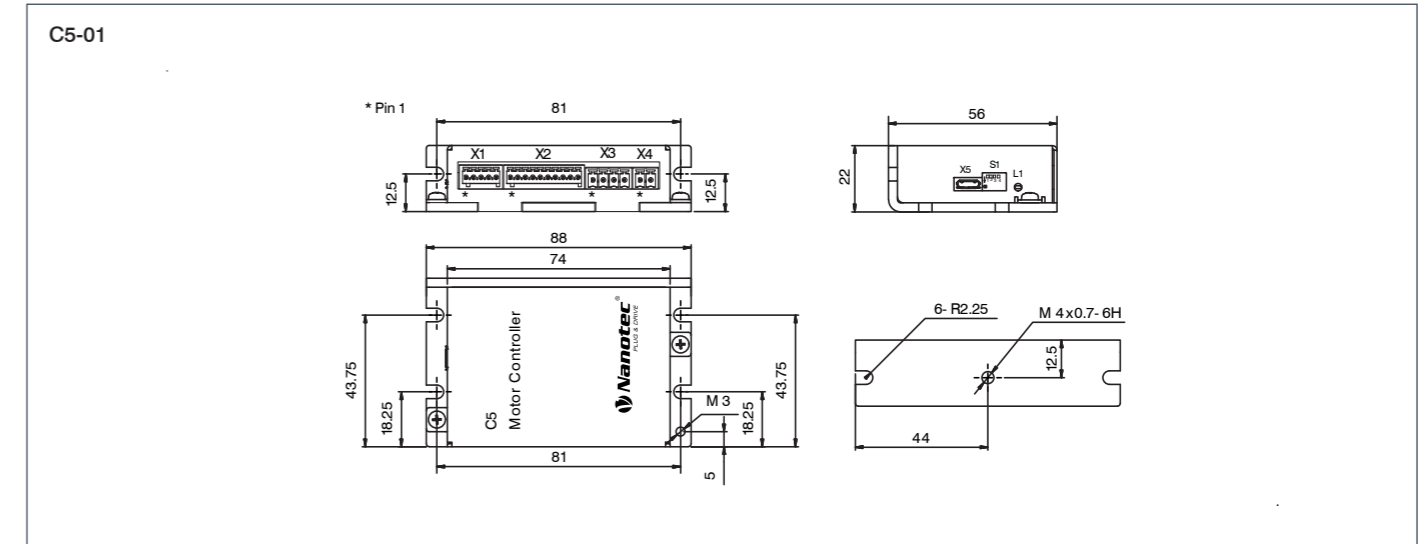



SOFTWARE



TECHNICAL DATA

Operating voltage	12-48 VDC +/- 5 %
Rated current	6 A (C5-E-1-09) or 10 A (C5-E-2-09)
Max. current (RMS)	6 A (C5-E-1-09) or 30 A (C5-E-2-09)
Operating modes	Profile position mode, profile velocity mode, profile torque mode, velocity mode, homing mode, cyclic sync position mode, cyclic sync velocity mode, cyclic sync torque mode, clock/direction mode and stand-alone mode (controlled by JAVA Program)
Interface	CANopen and Micro USB
Encoder	5 V single-ended or differential signal, switchable by software, maximum resolution 65536 CPR (16 Bit)
Hall sensor	5 V single-ended signal
Input	5 digital inputs (5 V or 24 V, separately switchable by software), 1 analog input 10 Bit, 0-10 V or 0 - 20 mA (switchable by software), 1 analog input 10 Bit, 0 - 10 V
Output	3 transistor outputs (Open - Drain, max. 24 V/100 mA)
Dimensions	140x74x28 mm
Protective function	Over-/under voltage protection, over temperature protection (>75 °C), reverse polarity protection(Short-circuit +UB and GND for reverse polarity, needs fuse in supply cable!)

VERSIONS

Type	Min. Operating Voltage V	Max. Operating Voltage V	Nominal Current A	Controller for	Weight kg
C5-E-1-09	12	48	6	Stepper Motor, BLDC Motors	0.27
C5-E-2-09	12	48	10	Stepper Motor, BLDC Motors	0.27

ORDER IDENTIFIER

C5-E-
1-09 = Low-Current Version
2-09 = High-Current Version



ACCESSORIES

ZK-M12-8-2M-2-PADP M12 Cable
ZK-M12-12-2M-2-PADP M12 Cable
ZK-MICROUSB USB Cable
ZK-NOE-10-500-S-PADP Encoder Cable
ZK-PADP-12-500-S Encoder Cable



CAUTION



For stabilizing the operating voltage, we recommend using a sufficiently dimensioned decoupling capacitor.

DIMENSIONS (IN MM)

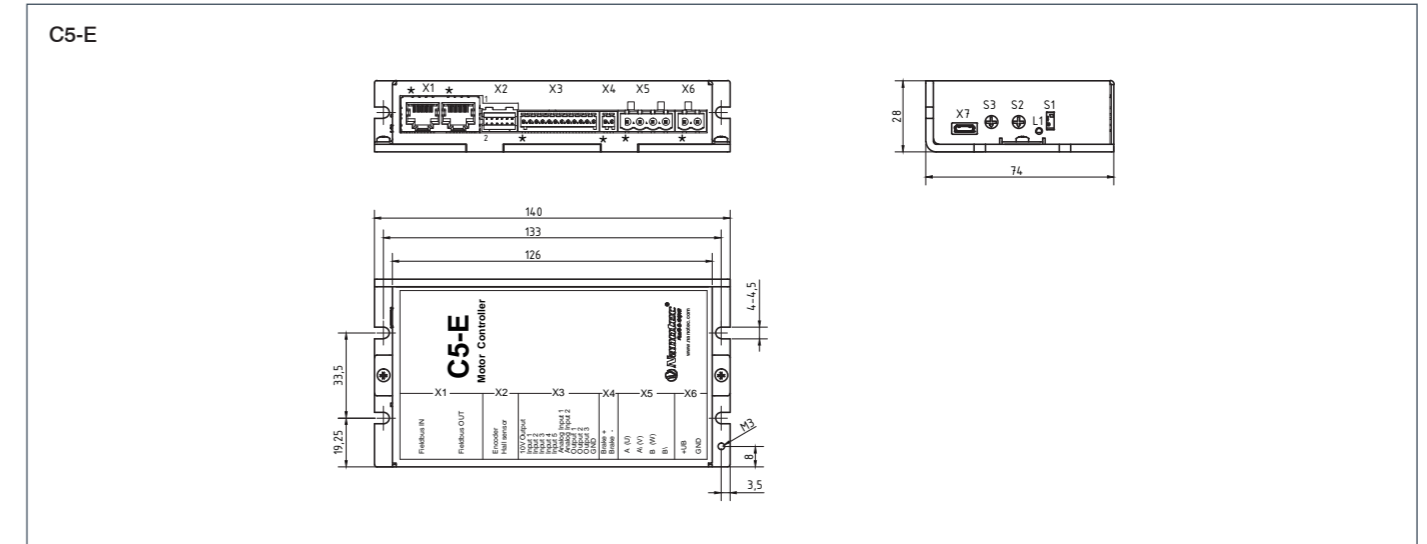



TECHNICAL DATA

Operating voltage	12 - 24 VDC +/- 5 %
Max. current (RMS)	3 A (CL3-E-1), 6 A (CL3-E-2)
Operating modes	profile position mode, profile velocity mode, profile torque mode, velocity mode, homing mode, cyclic sync position mode, cyclic sync velocity mode, cyclic sync torque mode, clock/direction mode and stand-alone mode (controlled by JAVA Program)
Motor control	Stepper open loop, stepper closed loop with encoder, BLDC closed loop with Hall sensor and BLDC closed loop with encoder
Interface	CANopen, RS485 2-wires, RS232 and Micro USB
Encoder	5 V single-ended signal, maximum resolution 65536 CPR (16 Bit)
Hall sensor	5 V single-ended signal
Input	5 digital inputs (5 V), 1 analog input 10 Bit, 0-10 V or 0-20 mA (switchable by software), 1 analog input 10 Bit, 0 to 10 V
Output	3 transistor outputs (Open-drain, max. 24 V/100 mA)
Protection circuit	Over-/undervoltage protection, Overtemperature protection (>75 °C), reverse polarity protection (short-circuit +UB and GND for reverse polarity, needs fuse in supply cable!)

VERSIONS

Type	Min. Operating Voltage V	Max. Operating Voltage V	Peak Current A	Controller for	Weight kg
CL3-E-1-0F	12	24	3	Stepper Motor, BLDC Motors	0.02
CL3-E-2-0F	12	24	6	Stepper Motor, BLDC Motors	0.02

ORDER IDENTIFIER

CL3-E-
 1-0F = Low-Current Version
 2-0F = High-Current Version



ACCESSORIES

ZK-GHR3-500-S	RS232 Cable
ZK-GHR12-500-S	IO Cable
ZK-GHR10-500-S-GHR	Encoder Cable
ZK-GHR13-500-S-GHR	Encoder Cable
ZK-MICROUSB	USB Cable
ZK-PD4-C-CAN-4-500-S	CANopen/ RS485 Cable
ZK-XHP2-500-S	Power Cable



CAUTION

For stabilizing the operating voltage, we recommend using a sufficiently dimensioned decoupling capacitor.

DIMENSIONS (IN MM)

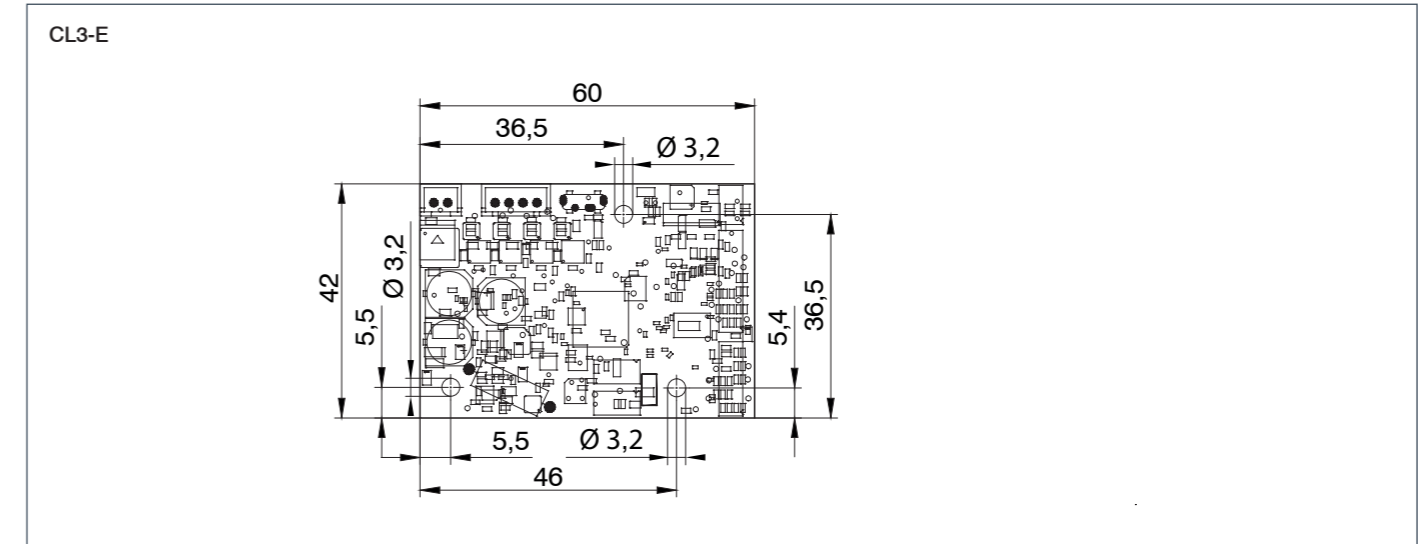

Our stepper and BLDC motors, linear actuators and linear positioning drives, together with a wide selection of gears and encoders, create a modular system with over 4000 possible combinations. Our easy-to-use online configurator will help you select the right products for your particular application:

- Broad product spectrum
- Rapid and easy selection
- Comprehensive documentation
- Direct ordering

Extensive product information is available directly on the Nanotec website for viewing and downloading. This includes product details such as technical drawings, 3D data, delivery times and parts lists. Find out more at www.nanotec.com

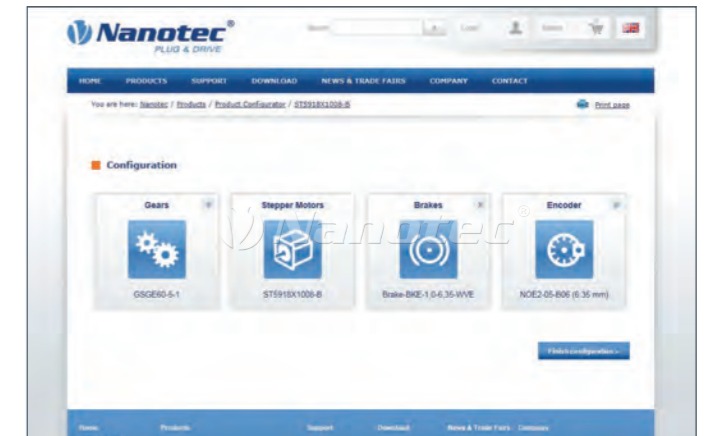
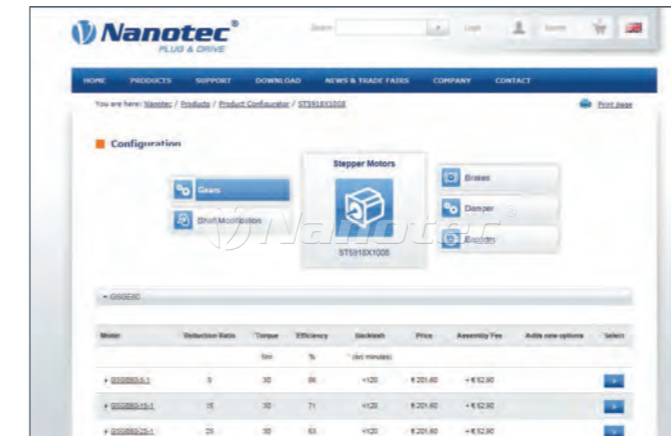

GEAR



MOTOR



BRAKE



ENCODER



CUSTOM MACHINING

Nanotec also supplies shafts with customer-specific designs for all motors of the ST and DB series as well as IP motors. The tolerances specified below are standard for large order quantities. Please note that these cannot always be adhered to when post-machining bearing motors in small numbers. In addition, when a shaft is subsequently machined, a minimum distance of 3 mm must always be maintained to the surface of the centering flange.

D-CUT

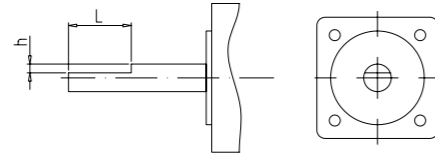

Motor size	L	h
20-35	±0.2	±0.1
39-42	±0.2	±0.1
59-60	±0.25	±0.15
89-110	±0.5	±0.2

In addition to D-cut, 90° and triangular flattening, we also produce shafts with flat surfaces for setting screws, relief grooves for lock rings and threaded blind holes according to customer specifications. The shaft is flattened to enable simple and form-fitting fixation and to effectively prevent the load from rotating.

MACHINED SHAFT/THINNER SHAFT

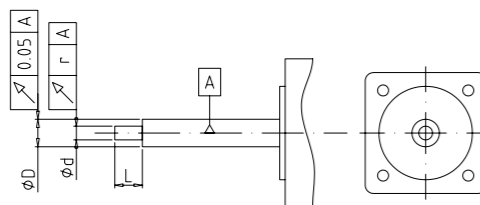

Motor size	L	L	d	r
20-35	±0.1 (<20)	±0.15 (<20)	-0.012	<0.02
39-42	±0.1 (<20)	±0.15 (<20)	-0.012	<0.05
59-60	±0.1 (<20)	±0.15 (20-50)	-0.012	<0.05
89-110	±0.5 (<20)	±0.5 (20-50)	-0.012 (d≥4 (L<20))	<0.02 (L<20)

Machined shafts are used primarily to attach transmission elements with smaller bore diameters directly onto the motor shaft. Additional machining is possible even if only a small number of pieces is ordered.

SIDE-DRILLED HOLE

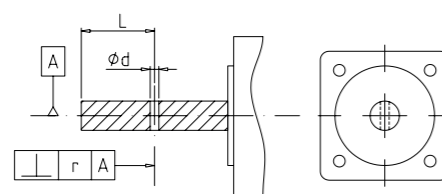

Motor size	L	d	r
20-35	±0.1	+0.1	0.1
39-42	±0.15	+0.1 ¹⁾	0.2
59-60	±0.2	+0.1	0.1
89-110	±0.5	+0.2	0.1

Side-drilled holes can be used to securely attach clamping pins in order to meet the high directional and load change requirements of transmission elements.

GROOVE

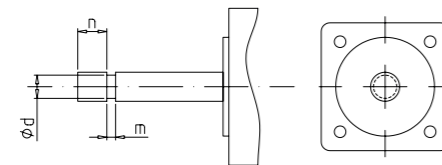

Motor size	n	m	d
20-35	±0.2	±0.2	±0.2
39-42	±0.2	2)	3)
59-60	±0.25	±0.15	±0.1
89-110	±0.5	±0.2	-0.022

Shaft grooves on motors are used for comfortably attaching safety disks that axially fix timing pulleys, spur gears, etc.

KEYWAY

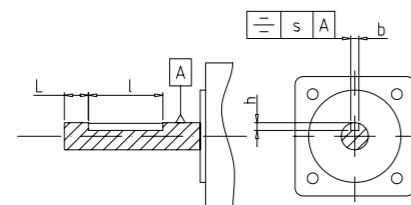

Motor size	n	m	d
20-35	±0.2	±0.2	±0.2
39-42	±0.2	2)	3)
59-60	±0.25	±0.15	±0.1
89-110	±0.5	±0.2	-0.022

Systems that are subject to high load and directional changes benefit from shafts with keyways that provide reliable rotation protection.

ACCESSORIES/GEAR WHEELS

TIMING PULLEY



Nanotec supplies synchronous pulleys in metric and imperial dimensions, with and without a hub or tapered adapter sleeve, and with a variety of tooth profiles, forms and pitches.

SHAFT WITH METRIC THREAD



Shafts with a metric thread are an ideal solution for rotating elements and linear low-speed positioning drives.

TOOTHED SHAFT



Motors with toothed shafts are used for easy mounting on existing reduction ratios, gears, etc.

CLAMPING BOLT



Clamping bolts enable secure clamping with a relatively large displacement path and high clamping force. When space is restricted, they can also be used for automatic adjustment.

BRASS OR STEEL INPUT PINION



Motors with a pinion on the motor shaft are used for mounting directly on existing reduction ratios.

WORM GEARS



Motors with a mounted worm gear can be installed at a 90° angle to the load and thus provide a large reduction ratio in a very limited space. Their efficiency is between 30 and 70%, depending on the reduction ratio.

MODIFICATIONS IN QUANTITY

Nanotec offers machining for all motors of the ST and DB series as well as motors with protection class and Plug & Drive motors. Depending on the complexity of the machining a minimum order quantity between 100 and 1000 pcs is required.

LARGER SHAFT



Larger or thicker shafts are primarily used for high radial forces.

SPECIAL SHAFT FORMS



With square or hexagonal shafts, systems can be easily and quickly adapted to various tools and other equipment during manual or motorized adjustments.

HOLLOW SHAFT



Hollow shafts make it possible to pass cables, hoses, screws and laser beams through them.

TIMING BELT



Shafts with timing belts are very smooth running while exhibiting low belt tension and low bearing load.

CABLE ASSEMBLY OPTION

Customer-specific connectors and cables allow simple and fast connection to existing machines. For orders with a minimum quantity of 100 pcs Nanotec offers connector and cable assemblies ex works.

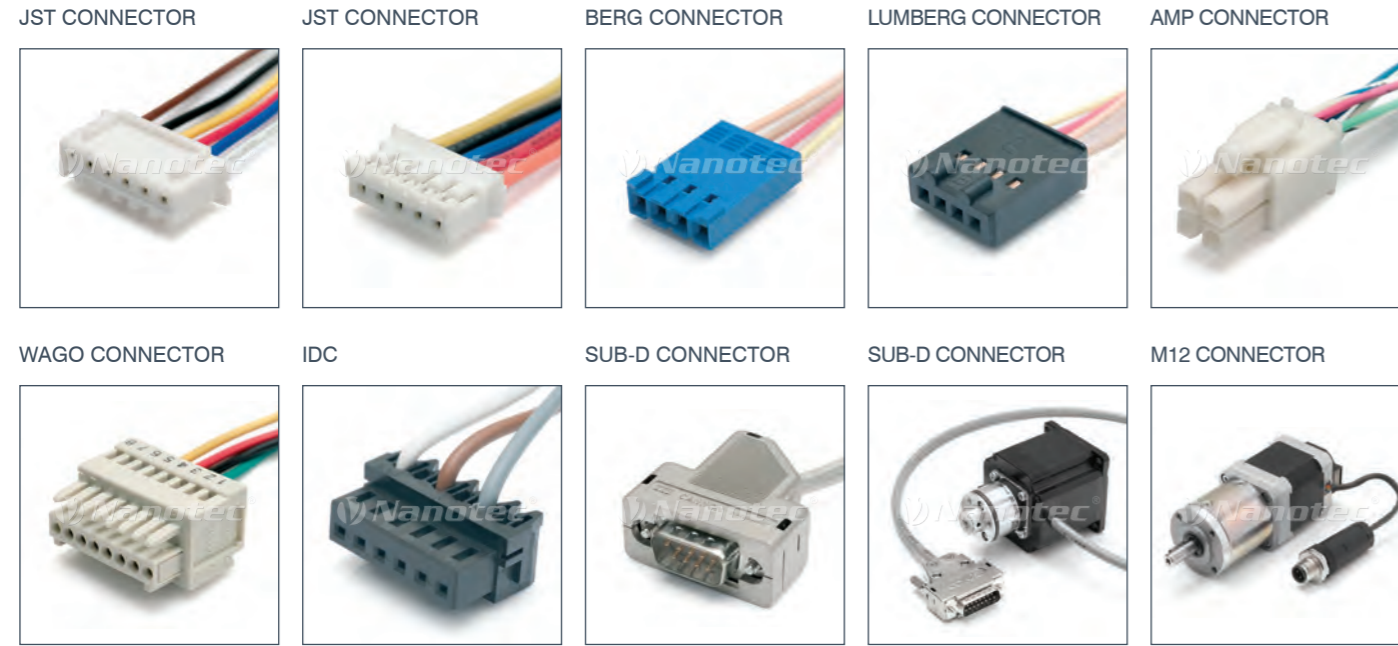

CABLE ASSEMBLY



INTEGRATED PLUG



Notes section with horizontal lines for writing.



TECHNICAL DATA

Resolution	500, 1000 pulses/revolution
Signal form	Square wave signal
Output signals	WEDS: Phase A, B, I WEDL: Phase A, A\, B, B\, I, I\
Operating voltage	5 VDC
Current consumption	≤60 mA
Limit frequency	100 KHz
Limit speed	1000 pulses/revolution = 6000 rpm, 500 pulses/revolution = 12000 rpm
Pulse width	90 ° ± 45 °
Signal level	VH 85% VCC, VL ≤0.3 V
Max. output current per channel	±150 mA, recommended working current ±20
Working temperature	-25 °C to 100 °C
Storage temperature	-40 °C to 100 °C
Humidity	30 to 85%, non-condensing

VERSIONS

Type	Index	Line Driver	Signal Voltage V	Cycles per Revolution
WEDL5541-A	Yes	Yes	5	500
WEDL5541-B	Yes	Yes	5	1000
WEDS5541-A	Yes	No	5	500
WEDS5541-B	Yes	No	5	1000

ORDER IDENTIFIER

WEDL5541-A
 14 = 5 mm Shaft Diameter
 06 = 6.35 mm Shaft Diameter

ACCESSORIES

- ZK-WEDL-8-1000-S Encoder Cable
- ZK-WEDL-8-2000-S Encoder Cable
- ZK-WEDL-8-500 Encoder Cable
- ZK-WEDL-8-500-S Encoder Cable
- ZK-WEDS-300-S-SMCI35 Encoder Cable
- ZK-WEDS-5-150-S Encoder Cable
- ZK-WEDS-5-500 Encoder Cable
- ZK-WEDS-5-500-S Encoder Cable

CAUTION

To mount the encoder the Nanotec Mounting KIT is required. Please refer to our website for ordering.

DIMENSIONS (IN MM)

WEDL-WEDS5541 (1000 Ink.)

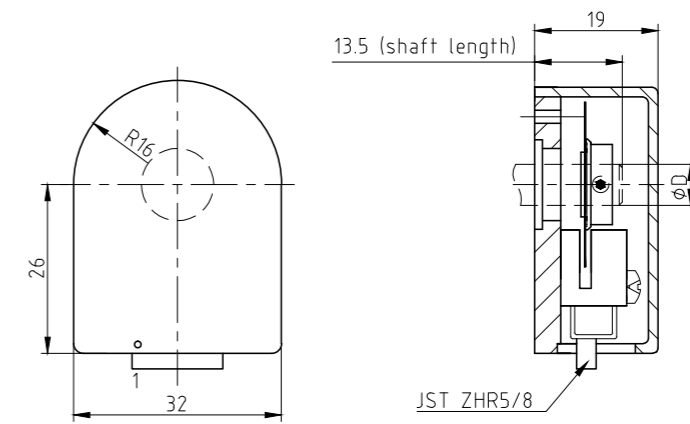

WEDL-WEDS5541 (500 Ink.)

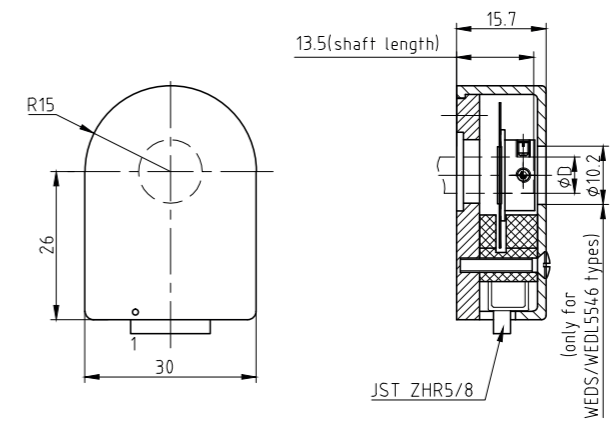



TECHNICAL DATA

Resolution	500, 1000, 2000 pulses/revolution
Signal form	Square wave signal
Output signals	Phase A, A\, B, B\, I, I\
Operating voltage	5 VDC (7 VDC max.)
Current consumption	typical 100 mA
Limit frequency	60 KHz (500 CPR), 120 KHz (1000 CPR), 240 KHz (2000 CPR)
Limit speed	6600 rpm
Pulse width	180 ° ± 50 °
Phase shift	90 ° ± 50 °
Signal level	Low 0 V; High: +3,5 V (±10%, without lead), +3 V (±10%, with lead 20 mA)
Max. output current per channel	± 150 mA, recommended working current ±20
Working temperature	-20 to 85 °C
Storage temperature	-40 to 85 °C
Humidity	Max. 90%, non-condensing

VERSIONS

Type	Index	Line Driver	Signal Voltage V	Cycles per Revolution
NOE1-05-A	Yes	Yes	5	500
NOE1-05-B	Yes	Yes	5	1000
NOE1-05-C	Yes	Yes	5	2000

ORDER IDENTIFIER

NOE1-05-A
 12 = 6 mm, Type: Hollow Shaft
 14 = 5 mm Shaft Diameter



ACCESSORIES

ZK-NOE1-10-500-S Encoder Cable
ZK-NOE1-10-2000-S Encoder Cable



CAUTION



Please note that the NOE1 encoders are only available together with a motor and must be mounted by Nanotec.

DIMENSIONS (IN MM)

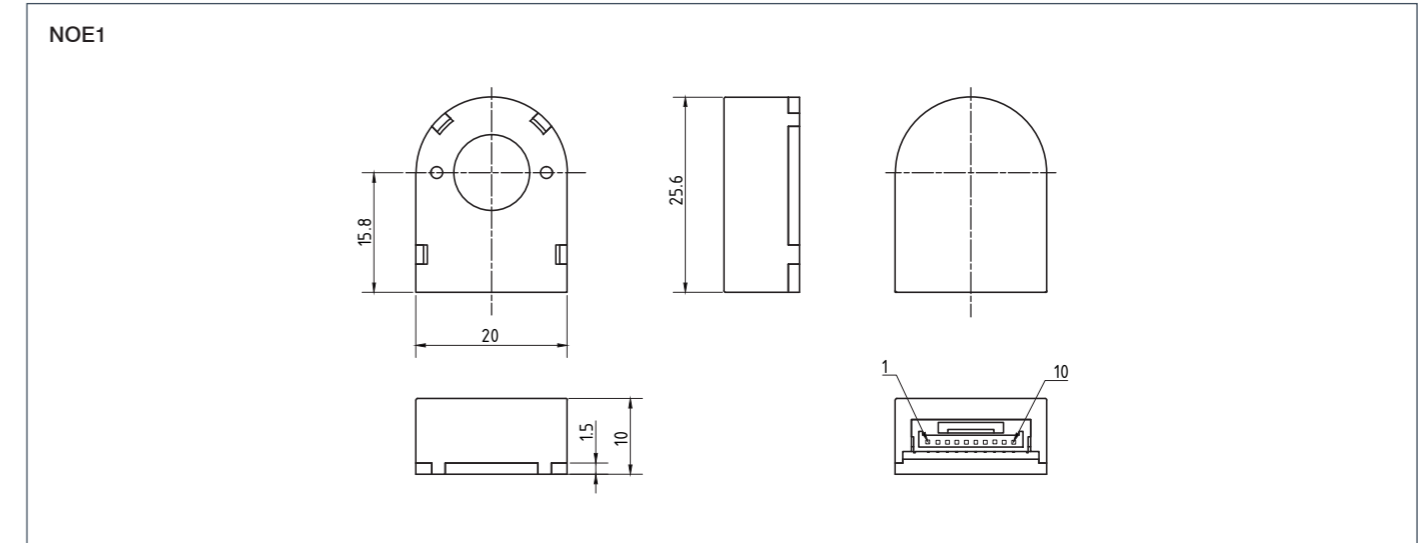

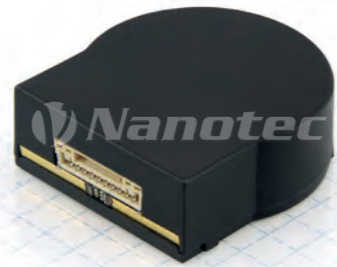

TECHNICAL DATA

	NOE2-05	NOE2-24
Resolution	1000, 2000, 4000 pulses/revolution	1000, 2000, 4000 pulses/revolution
Signal form	Square wave signal	Square wave signal
Output signals	Phase A, A\, B, B\, I, I\	Phase A, A\, B, B\, I, I\
Operating voltage	DC 4.5 V to 5.5 V	24 VDC
Current consumption	typical 30 mA	typical 15 mA
Limit frequency	60 KHz (1000 CPR), 120 KHz (2000 CPR), 240 KHz (4000 CPR)	60 KHz (1000 CPR), 120 KHz (2000 CPR), 240 KHz (4000 CPR)
Limit speed	3600 rpm	3600 rpm
Pulse width	180 ° ± 30 °e	180 ° ± 30 °e
Phase shift	90 ° ± 18 °e	90 ° ± 18 °e
Signal level	Low: 0 V; high: +3,5 V (±10 %, without lead), +3 V (±10 %, with lead 20 mA)	Low: 0 V, high: Vcc-0.5 V
Max. output current per channel	150 mA	200 mA
Working temperature	-20 to 85 °C	-20 to 85 °C
Storage temperature	-40 to 85 °C	-40 to 85 °C
Humidity	Max. 90%, non-condensing	Max. 90%, non-condensing

VERSIONS

Type	Index	Line Driver	Signal Voltage V	Cycles per Revolution
NOE2-05-B	Yes	Yes	5	1000
NOE2-05-K	Yes	Yes	5	4000
NOE2-24-B	Yes	Yes	24	1000
NOE2-24-K	Yes	Yes	24	4000

ORDER IDENTIFIER

NOE2-05-B
 14 = 5 mm Shaft Diameter
 06 = 6.35 mm Shaft Diameter
 10 = 10 mm, Type Hollow Shaft
 15 = 15 mm, Type Hollow Shaft

ACCESSORIES

ZK-NOE1-10-500-S Encoder Cable

CAUTION

Please note that the NOE1 encoders are only available together with a motor and must be mounted by Nanotec.

DIMENSIONS (IN MM)

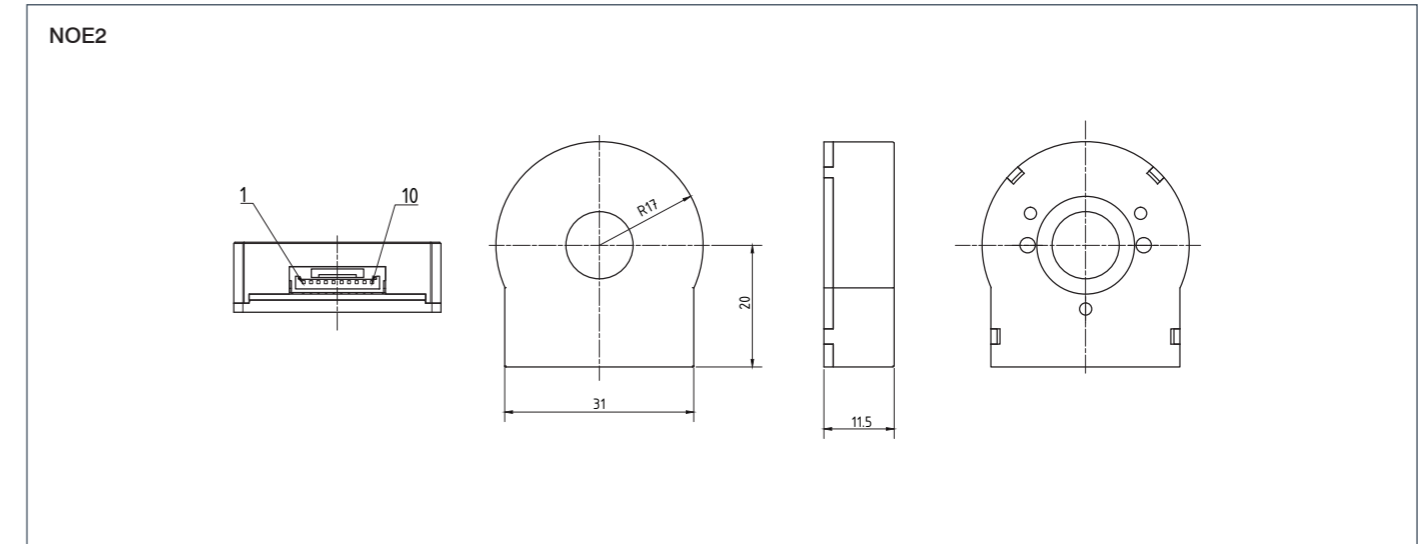



TECHNICAL DATA

Resolution	max. 1024 CPR/4096 PPR, 12 Bit absolute
Signal form	Square wave signal, sine/cosine
Output signals	NME1-USW: A,/A, B, /B, I, /I, H1, H2, H3, NME1-SSI: sine, cosine, SSI (12 Bit)
Operating voltage	+5 bis +24 VDC, ±10%
Limit frequency	1000 HZ for sine signal and 500 HZ for 4096 interpolation
Limit speed	30.000 rpm
Pulse width	180 ° ± 30 °e
Phase shift	90° ± 18 °e
Signal level	incremental signal - low: 0 V, high: Vcc-0.5 V SSI: TTL, sine/cosine: 1.5 V ± 0.8 V
Max. output current per channel	150 mA
Working temperature	-20 to 85 °C
Storage temperature	-40 to 85 °C
Humidity	Max. 90 %, non-condensing

VERSIONS

Type	Index	Line Driver	Signal Voltage V	Cycles per Revolution
NME1-UVW-T	Yes	Yes	5-24	1024

ORDER IDENTIFIER

NME1-UVW-T
06 = 5 mm Shaft Diameter
14 = 6.35 mm Shaft Diameter



ACCESSORIES

ZK-NME1-13-500-S Encoder Cable



CAUTION



Please note that the NOE1 encoders are only available together with a motor and must be mounted by Nanotec.

DIMENSIONS (IN MM)

NME1

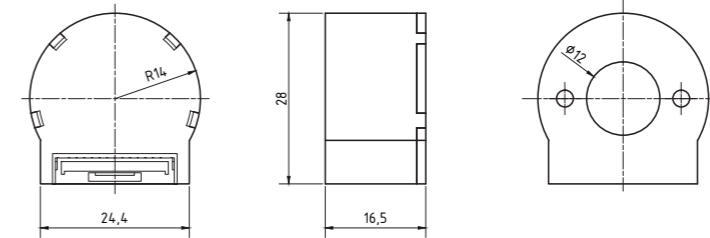



CAUTION



Please note that the GPLE22 gears are only available together with a motor.

TECHNICAL DATA

IP protection	IP43
Service life	10.000 hours
Combination with motor	NEMA 8, 11, 17
Working temperature	-25 °C to 90 °C
Admissible radial/axial shaft load (N)	20/20
Moment of inertia kg mm²	0.09

VERSIONS

Type	Reduction Ratio	Output Torque Nominal Nm	Efficiency %	Backlash ' (arc minutes)	Moment of Inertia kg mm ²	Length „A“ mm	Intermediate Flange L1 mm	Weight kg
GPLE22-2S-9	9	1.5	80	<55	0.09	34	4.3, 4.45*	0.1
GPLE22-2S-12	12	1.5	80	<55	0.09	34	4.3, 4.45*	0.1
GPLE22-2S-15	15	1.5	80	<55	0.09	34	4.3, 4.45*	0.1

* The intermediate flange size (L1) of NEMA 8 and 11 motors is 4.45 mm and 4.3 mm for NEMA 17 motors.

DIMENSIONS (IN MM)

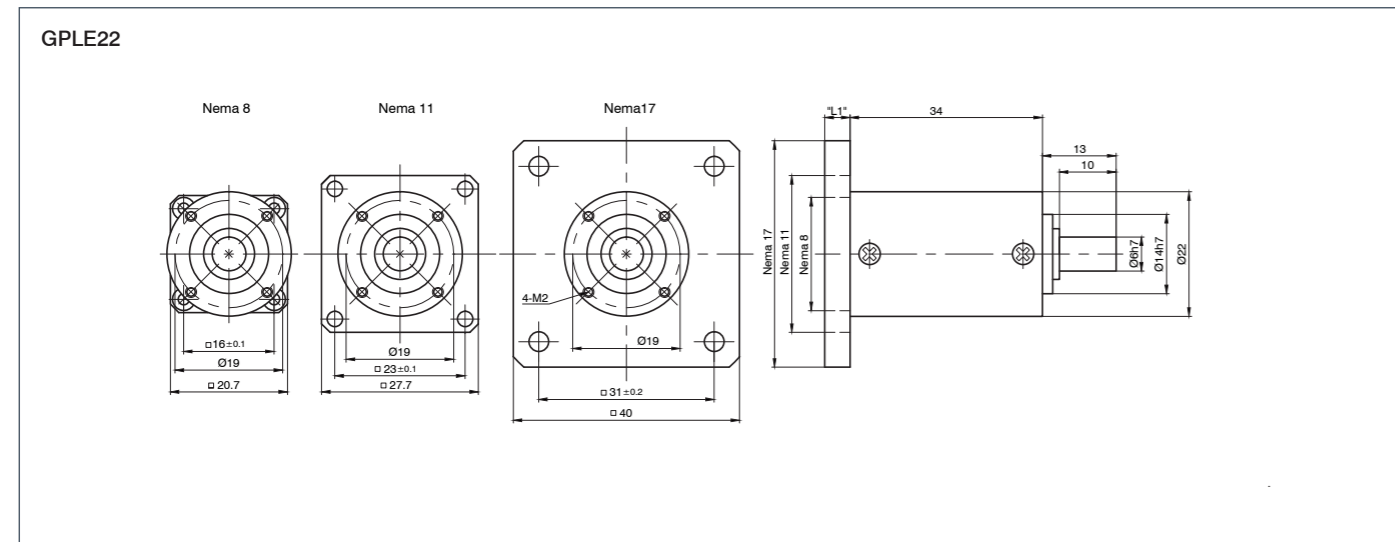

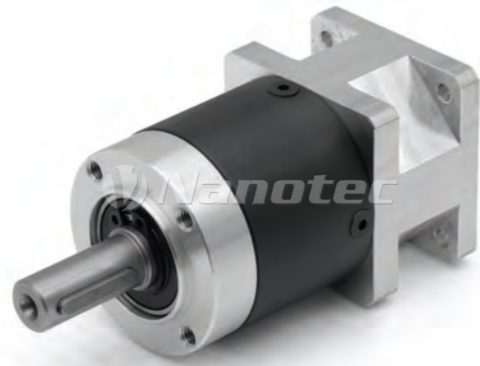

ORDER IDENTIFIER

GPLE40-1S-3
 = for NEMA 17 Motor
 F56 = for NEMA 23, 24 Motor

TECHNICAL DATA

IP protection	IP54
Service life	30.000 hours
Combination with motor	NEMA 17, 23, 24
Working temperature	-25 °C to 90 °C
Admissible radial/axial shaft load (N)	200/200, (160/160)

DIMENSIONS (IN MM)

GPLE40

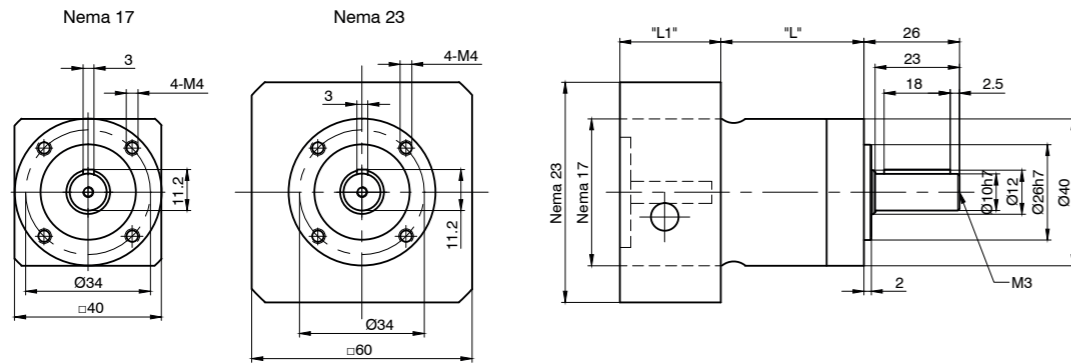

VERSIONS

Type	Reduction Ratio	Output Torque Nominal Nm	Output Torque Max. Value Nm	Efficiency %	Backlash ' (arc minutes)	Moment of Inertia kg mm ²	Length „A“ mm	Intermediate Flange L1 mm	Weight kg
GPLE40-1S-3	3	11	17.5	97	<15	3.1	39	24.5, 27.5*	0.35
GPLE40-1S-4	4	15	24	97	<15	2.2	39	24.5, 27.5*	0.35
GPLE40-1S-5	5	14	22	97	<15	1.9	39	24.5, 27.5*	0.35
GPLE40-1S-8	8	6	10	97	<15	1.7	39	24.5, 27.5*	0.35
GPLE40-2S-9	9	16.5	26	95	<19	3	52	24.5, 27.5*	0.45
GPLE40-2S-12	12	20	32	95	<19	2.9	52	24.5, 27.5*	0.45
GPLE40-2S-15	15	18	29	95	<19	2.3	52	24.5, 27.5*	0.45
GPLE40-2S-16	16	20	32	95	<19	2.2	52	24.5, 27.5*	0.45
GPLE40-2S-20	20	20	32	95	<19	1.9	52	24.5, 27.5*	0.45
GPLE40-2S-25	25	18	29	95	<19	1.9	52	24.5, 27.5*	0.45
GPLE40-2S-32	32	20	32	95	<19	1.7	52	24.5, 27.5*	0.45
GPLE40-2S-40	40	18	29	95	<19	1.6	52	24.5, 27.5*	0.45
GPLE40-2S-64	64	7.5	12	95	<19	1.6	52	24.5, 27.5*	0.45
GPLE40-3S-60	60	20	32	91	<22	2.9	64.5	24.5, 27.5*	0.55
GPLE40-3S-80	80	20	32	91	<22	1.9	64.5	24.5, 27.5*	0.55
GPLE40-3S-100	100	20	32	91	<22	1.9	64.5	24.5, 27.5*	0.55
GPLE40-3S-120	120	18	29	91	<22	2.9	64.5	24.5, 27.5*	0.55
GPLE40-3S-160	160	20	32	91	<22	1.6	64.5	24.5, 27.5*	0.55
GPLE40-3S-200	200	18	29	91	<22	1.6	64.5	24.5, 27.5*	0.55
GPLE40-3S-256	256	20	32	91	<22	1.6	64.5	24.5, 27.5*	0.55
GPLE40-3S-320	320	18	29	91	<22	1.6	64.5	24.5, 27.5*	0.55
GPLE40-3S-512	512	7.5	12	91	<22	1.6	64.5	24.5, 27.5*	0.55

* The intermediate flange size (L1) of NEMA 23 and 24 motors is 24.5 mm and 27.5 mm for NEMA 17 motors.



TECHNICAL DATA

IP protection	IP54
Service life	30.000 hours
Combination with motor	NEMA 23, 24, 34
Working temperature	-25 °C to 90 °C
Admissible radial/axial shaft load (N)	400/500, (340/450)

DIMENSIONS (IN MM)

GPLE60

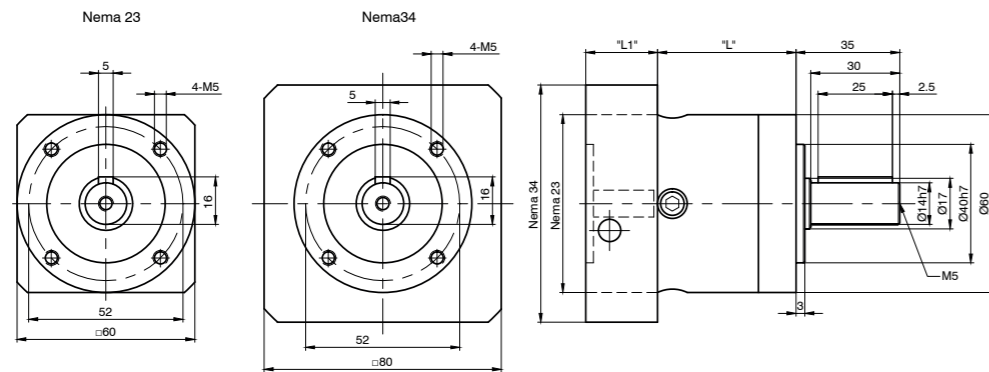

ORDER IDENTIFIER

GPLE60-1S-3
 = for NEMA 23, 24 Motor
 -F87 = for NEMA 34 Motor



ACCESSORIES

MK-DH-8-11-GPLE Spacer Sleeve



VERSIONS

Type	Reduction Ratio	Output Torque Nominal Nm	Output Torque Max. Value Nm	Efficiency %	Backlash (arc minutes)	Moment of Inertia kg mm ²	Length „A“ mm	Intermediate Flange L1 mm	Weight kg
GPLE60-1S-3	3	28	45	97	<10	13.5	47	24, 39*	0.9
GPLE60-1S-4	4	38	61	97	<10	9.3	47	24, 39*	0.9
GPLE60-1S-5	5	40	64	97	<10	7.8	47	24, 39*	0.9
GPLE60-1S-8	8	18	29	97	<10	6.5	47	24, 39*	0.9
GPLE60-2S-9	9	44	70	95	<12	13.1	59.5	24, 39*	1.1
GPLE60-2S-12	12	44	70	95	<12	12.7	59.5	24, 39*	1.1
GPLE60-2S-15	15	44	70	95	<12	7.7	59.5	24, 39*	1.1
GPLE60-2S-16	16	44	70	95	<12	8.8	59.5	24, 39*	1.1
GPLE60-2S-20	20	44	70	95	<12	7.5	59.5	24, 39*	1.1
GPLE60-2S-25	25	40	64	95	<12	7.5	59.5	24, 39*	1.1
GPLE60-2S-32	32	44	70	95	<12	6.4	59.5	24, 39*	1.1
GPLE60-2S-40	40	40	64	95	<12	6.4	59.5	24, 39*	1.1
GPLE60-2S-64	64	18	29	95	<12	6.4	59.5	24, 39*	1.1
GPLE60-3S-60	60	44	70	91	<15	7.6	72	24, 39*	1.3
GPLE60-3S-80	80	44	70	91	<15	7.5	72	24, 39*	1.3
GPLE60-3S-100	100	44	70	91	<15	7.5	72	24, 39*	1.3
GPLE60-3S-120	120	44	70	91	<15	6.4	72	24, 39*	1.3
GPLE60-3S-160	160	44	70	91	<15	6.4	72	24, 39*	1.3
GPLE60-3S-200	200	40	64	91	<15	6.4	72	24, 39*	1.3
GPLE60-3S-256	256	44	70	91	<15	6.4	72	24, 39*	1.3
GPLE60-3S-320	320	40	64	91	<15	6.4	72	24, 39*	1.3
GPLE60-3S-512	512	18	29	91	<15	6.4	72	24, 39*	1.3

* The intermediate flange size (L1) of NEMA 23 and 24 motors is 24.5 mm and 39 mm for NEMA 34 motors.



ORDER IDENTIFIER

GPLE80-1S-F87
F87 = for NEMA 34 Motor

TECHNICAL DATA

IP protection	IP54
Service life	30.000 hours
Combination with motor	NEMA 34
Working temperature	-25 °C to 90 °C
Admissible radial/axial shaft load (N)	750/1000, (650/900)

DIMENSIONS (IN MM)

GPLE80

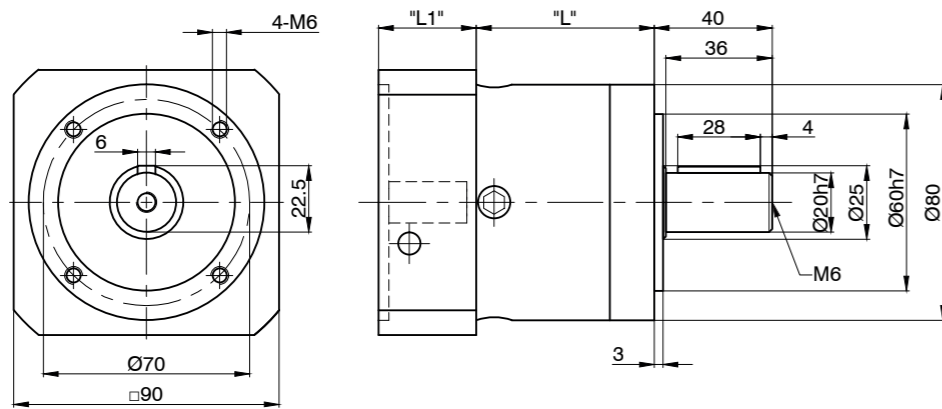

VERSIONS

Type	Reduction Ratio	Output Torque Nominal Nm	Output Torque Max. Value Nm	Efficiency %	Backlash (arc minutes)	Moment of Inertia kg mm ²	Length „A“ mm	Intermediate Flange L1 mm	Weight kg
GPLE80-1S-3-F87	3	85	136	97	<7	77	60.5	41.5	2.1
GPLE80-1S-4-F87	4	115	184	97	<7	52	60.5	41.5	2.1
GPLE80-1S-5-F87	5	110	176	97	<7	45	60.5	41.5	2.1
GPLE80-1S-8-F87	8	50	80	97	<7	39	60.5	41.5	2.1
GPLE80-2S-9-F87	9	130	208	95	<9	74	77.5	41.5	2.6
GPLE80-2S-12-F87	12	120	192	95	<9	72	77.5	41.5	2.6
GPLE80-2S-15-F87	15	110	176	95	<9	71	77.5	41.5	2.6
GPLE80-2S-16-F87	16	120	192	95	<9	50	77.5	41.5	2.6
GPLE80-2S-20-F87	20	120	192	95	<9	44	77.5	41.5	2.6
GPLE80-2S-25-F87	25	110	176	95	<9	44	77.5	41.5	2.6
GPLE80-2S-32-F87	32	120	192	95	<9	39	77.5	41.5	2.6
GPLE80-2S-40-F87	40	110	176	95	<9	39	77.5	41.5	2.6
GPLE80-2S-64-F87	64	50	80	95	<9	39	77.5	41.5	2.6
GPLE80-3S-60-F87	60	110	176	91	<11	51	95	41.5	3.1
GPLE80-3S-80-F87	80	120	192	91	<11	50	95	41.5	3.1
GPLE80-3S-100-F87	100	120	192	91	<11	44	95	41.5	3.1
GPLE80-3S-120-F87	120	110	176	91	<11	70	95	41.5	3.1
GPLE80-3S-160-F87	160	120	192	91	<11	39	95	41.5	3.1
GPLE80-3S-256-F87	256	120	192	91	<11	39	95	41.5	3.1
GPLE80-3S-320-F87	320	110	176	91	<11	39	95	41.5	3.1
GPLE80-3S-512-F87	512	50	80	91	<11	39	95	41.5	3.1

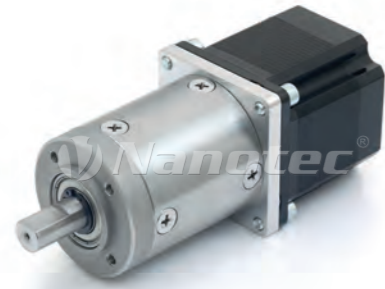

CAUTION



Please note that the GPLL gears are only available together with a motor.

TECHNICAL DATA

	GPLL22	GPLL40	GPLL52
Combination with motor	ST20/28, DB28	ST40/41/42, DB42	ST57/58/59/60 DB57/87
Axial/radial load (N)	7/10	30/50	100/200
Expected lifetime	LH 10 > 1000 hours		
Operating temperature	-10 °C to +80 °C		
Protection class	IP54		

VERSIONS

Type	Reduction Ratio	Output Torque Nominal Nm	Output Torque Max. Value Nm	Efficiency %	Backlash (arc minutes)	Length „A“ mm	Weight kg
GPLL22-5	5	0.2	60	80	<150	23.3	0.046
GPLL22-25	25	0.3	90	70	<150	29.5	0.051
GPLL22-90	90	0.4	120	60	<150	35.7	0.058
GPLL40-4	4	0.5	150	80	<180	27.5	0.191
GPLL40-14	14	1	300	70	<180	34.2	0.193
GPLL40-24	24	1	300	70	<180	34.2	0.193
GPLL40-49	49	1.8	540	60	<180	40.9	0.233
GPLL52-4	4	1.5	450	80	<180	53	0.475
GPLL52-15	15	5	1500	70	<180	68.5	0.66
GPLL52-53	53	10	3000	60	<180	84	0.85
GPLL52-100	100	10	3000	60	<180	84	0.85

DIMENSIONS (IN MM)

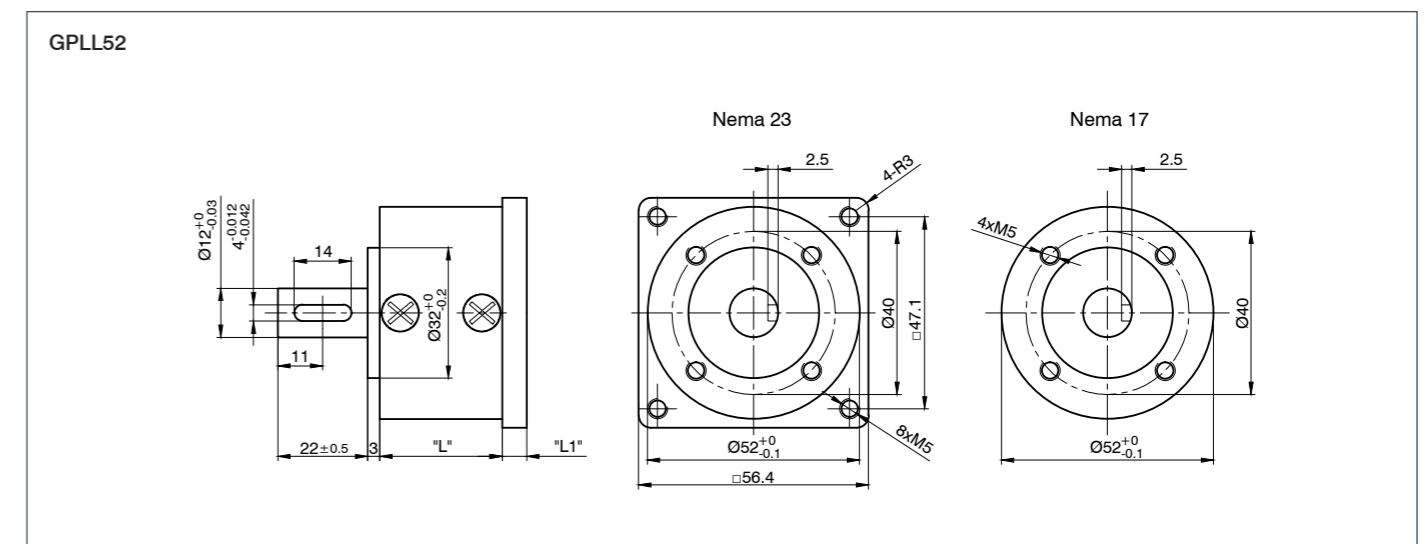
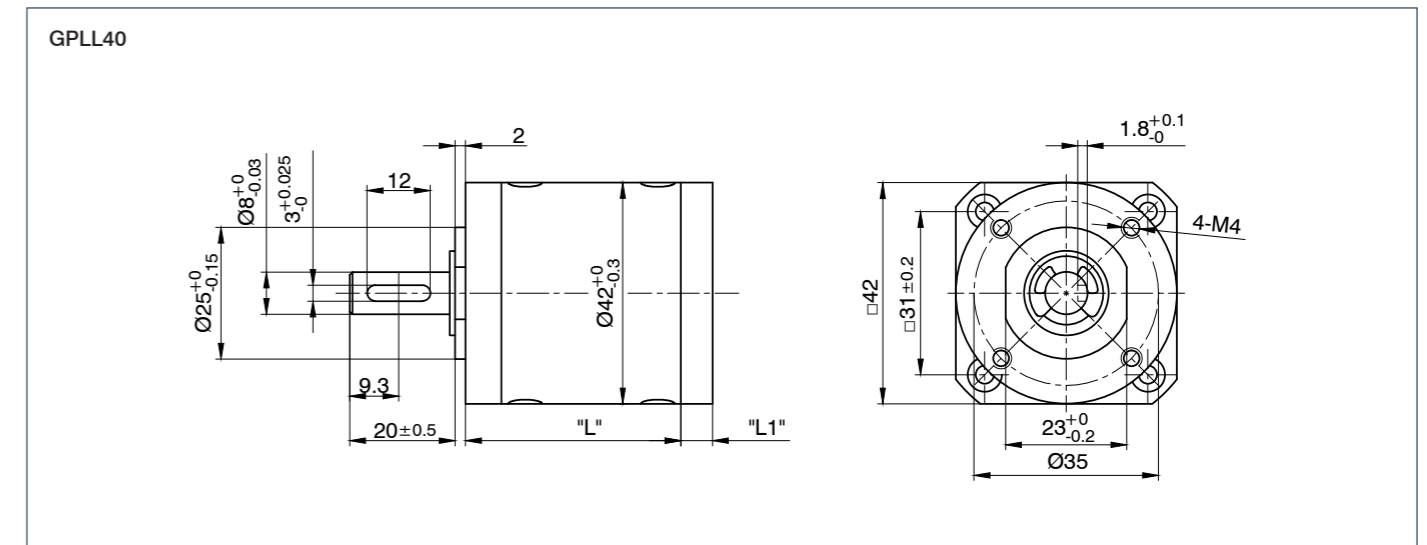
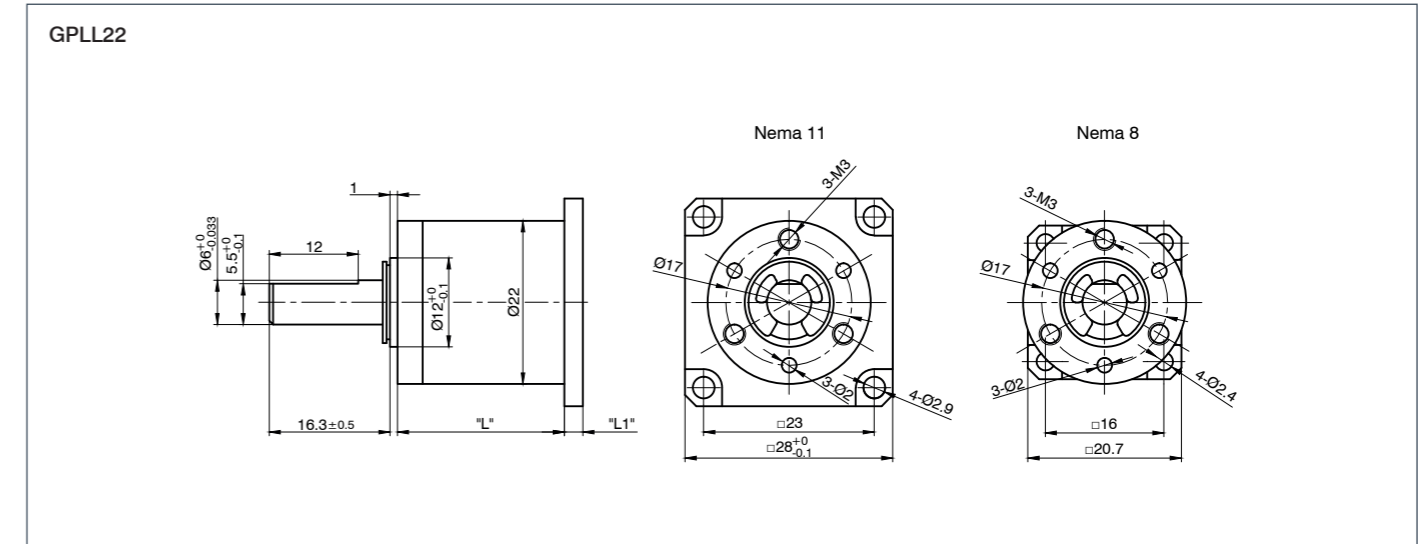

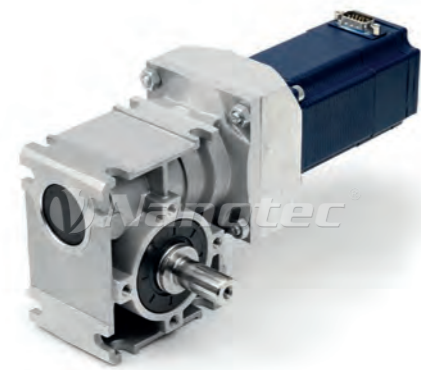

DESCRIPTION

Worm gears of the GSGE60 series can be mounted on any stepper motor size 56 x 56 mm (NEMA 23) and on stepper motors of the ST6018 series. They are pre-lubricated at the factory with a high-quality synthetic long-life lubricant and are maintenance free.

Because of their high backlash (appr. 1-2 °), worm gears are not suitable for positioning applications.

ACCESSORIES

Double Shaft Cover for GSGE60



CAUTION



Please note that the GSGE60 gears are only available together with a motor.

VERSIONS

Type	Reduction Ratio	Output Torque Nominal Nm	Efficiency %	Backlash ' (arc minutes)	Weight kg	Self-Locking Torque	Motor combination with
GSGE60-5-1	5	30	86	<120	2	No	Nema 23
GSGE60-15-1	15	30	71	<120	2	No	Nema 23
GSGE60-25-1	25	30	63	<120	2	No	Nema 23
GSGE60-50-1	50	30	45	<120	2	Yes	Nema 23

DIMENSIONS (IN MM)

GSGE60

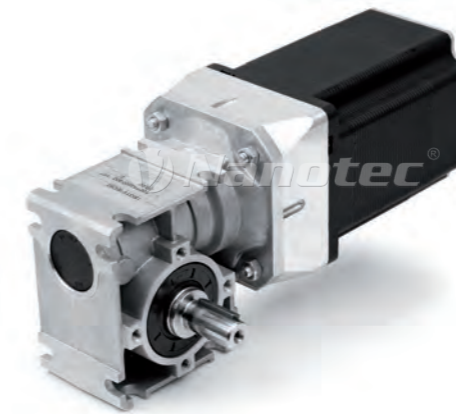
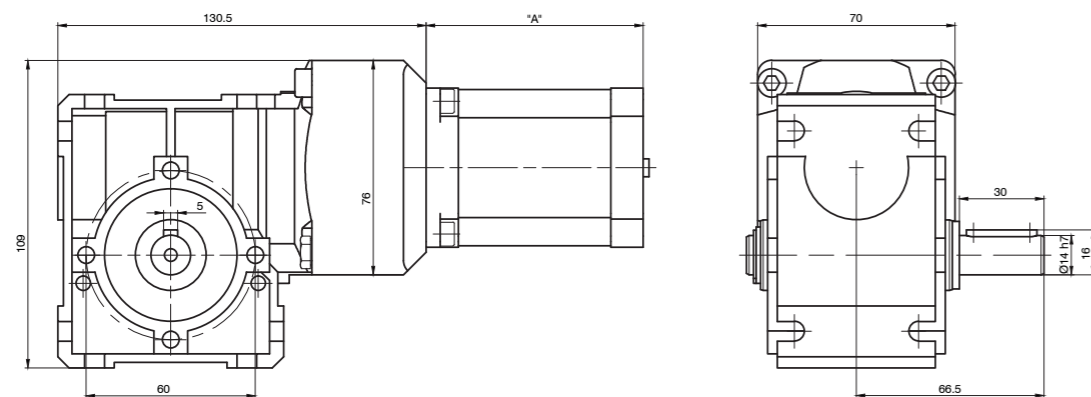

DESCRIPTION

The worm gears of the GSGE80 series can be mounted on any stepper motor size 86x86 mm (NEMA 34). They are pre-lubricated at the factory with a high-quality synthetic long-life lubricant and are maintenance free.

Because of their high backlash (appr. 1-2 °), worm gears are not suitable for positioning applications.

CAUTION



Please note that the GSGE80 gears are only available together with a motor.

VERSIONS

Type	Reduction Ratio	Output Torque Nominal Nm	Efficiency %	Backlash ' (arc minutes)	Weight kg	Self-Locking Torque	Motor combination with
GSGE80-12.5-1	12.5	50	80	<120	3	No	Nema 34
GSGE80-25-1	25	50	68	<120	3	No	Nema 34
GSGE80-50-1	50	50	50	<120	3	Yes	Nema 34

DIMENSIONS (IN MM)

GSGE80

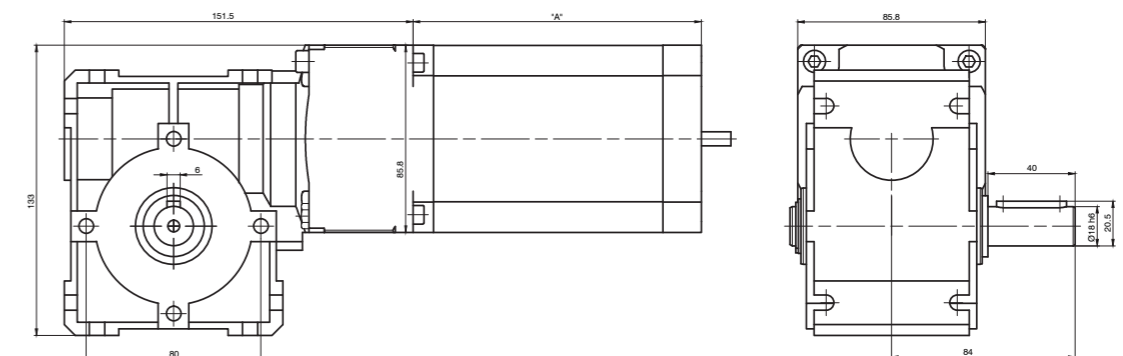



CAUTION

Please use the brake only as a safety brake! The brakes must be mounted by Nanotec.

TECHNICAL DATA

Electrical data	24 VDC/5 W
On/Off switching time	11 ms/17 ms
Hub	Borehole Ø5 H8 with 2 grub screws M3
Fastener	With 3 screws M2.5
Connection	Leads L=400 mm

VERSIONS

Type	Supply Voltage V	Holding Torque Ncm	Shaft Diameter mm	Moment of Inertia kg mm ²	Size mm	Weight kg
BRAKE-BL-0,24-5,0	24	24	5	1	37	0.1

DIMENSIONS (IN MM)

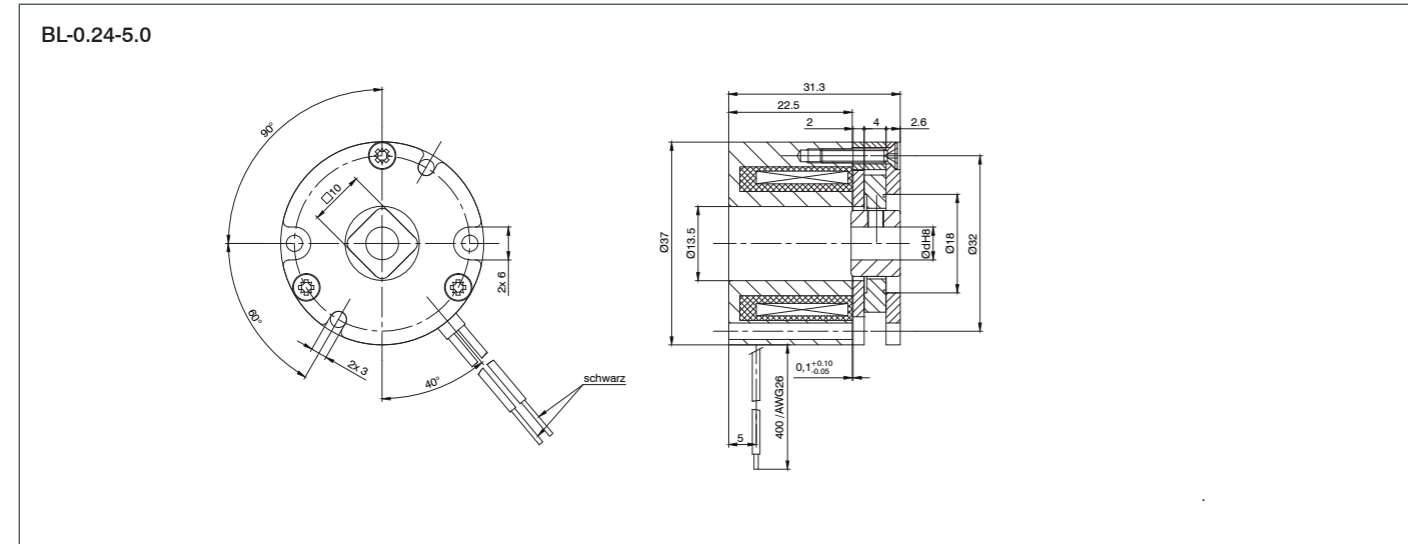

CAUTION

Please use the brake only as a safety brake! The brakes must be mounted by Nanotec.

TECHNICAL DATA

Electrical Data	24 VDC/10 W
On/Off switching time	35 ms/25 ms
Hub	Borehole Ø6.35 H7 with 2x setscrews M4x4 DIN916
Fastener	With 2 stud screws M3 or M4
Connection	Leads L = 400 mm

VERSIONS

Type	Supply Voltage V	Holding Torque Ncm	Shaft Diameter mm	Moment of Inertia kg mm ²	Size mm	Weight kg
BRAKE-BW-1,4-KAGF	24	140	6.35	10	55	0.5

DIMENSIONS (IN MM)

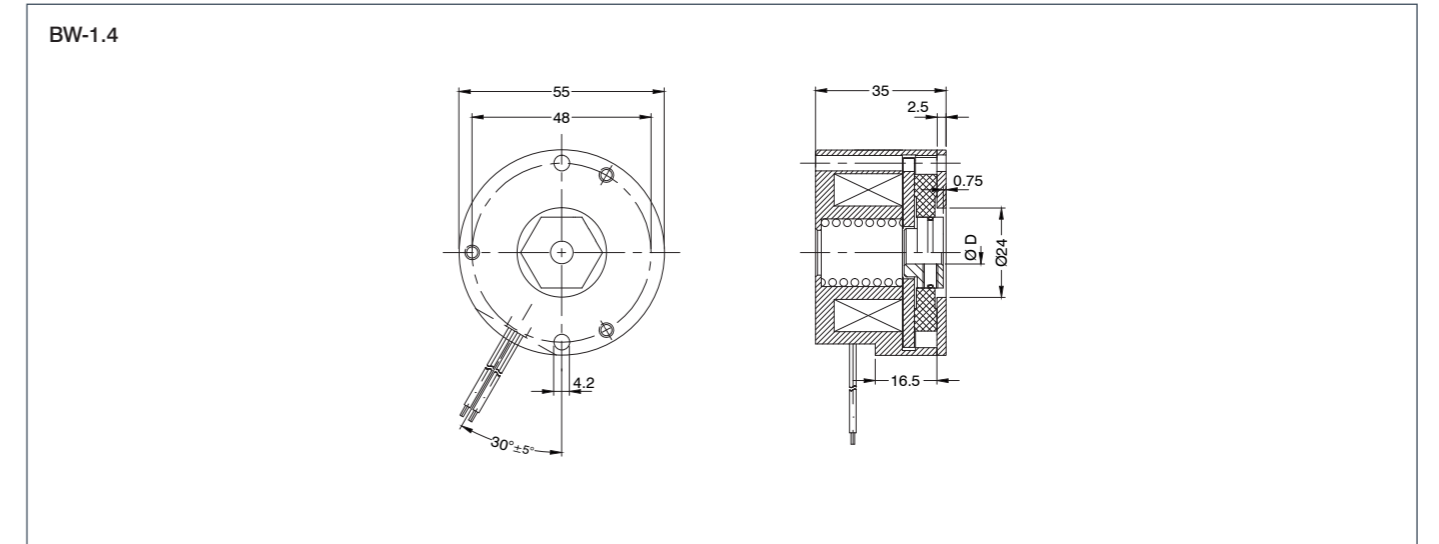



CAUTION



Please use the brake only as a safety brake! The brakes must be mounted by Nanotec.

TECHNICAL DATA

	BRAKE-BKE-0,4-5,0	BRAKE-BKE-1,0-6,35	BRAKE-BKE-2,0-6,35
Electrical data	24 VDC/8 W	24 VDC/10 W	24 VDC/11 W
On/Off switching time	10 ms/6 ms	12 ms/6 ms	25 ms / 6 ms
Hub	Borehole Ø5 H8 with 2 grub screws AM3x4	Borehole Ø6.35 H8 with 2 grub screws AM3x4	Borehole Ø6.35 H8 with 2 grub screws AM4x6
Fastener	With 4 M3 screws	With 4 M3 screws	With 4 M3 screws
Connection	Leads L=400 mm	Leads L=400 mm	Leads L=400 mm

VERSIONS

Type	Supply Voltage V	Holding Torque Ncm	Shaft Diameter mm	Moment of Inertia kg mm ²	Size mm	Weight kg
Brake-BKE-0,4-5,0	24	40	5	1.3	32	0.08
Brake-BKE-1,0-6,35	24	100	6.35	2.1	34	0.11
Brake-BKE-2,0-6,35	24	200	6.35	6,7	42	0.185

DIMENSIONS (IN MM)

BKE-0.4-5.0

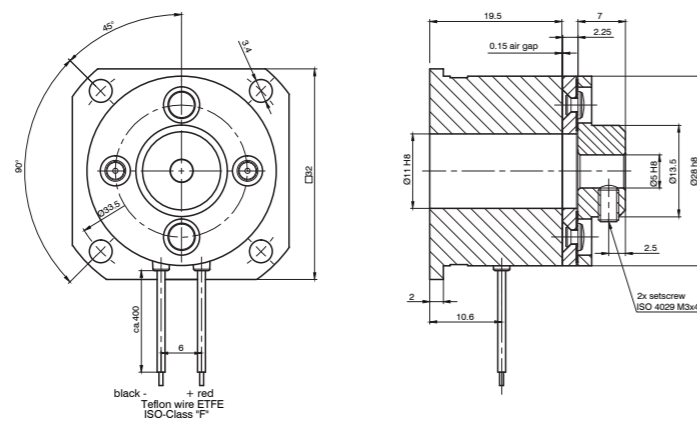

DIMENSIONS (IN MM)

BKE-1.0-6.35

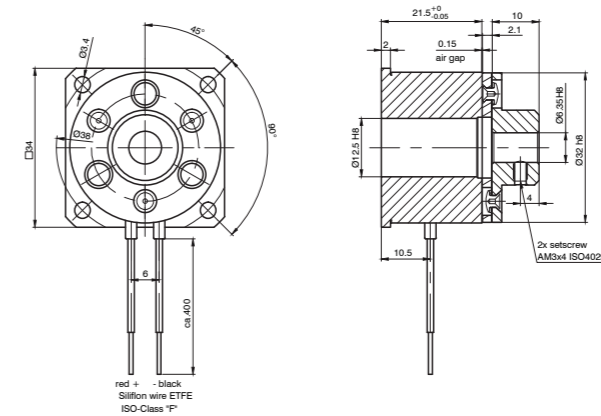

BKE-2.0-6.35

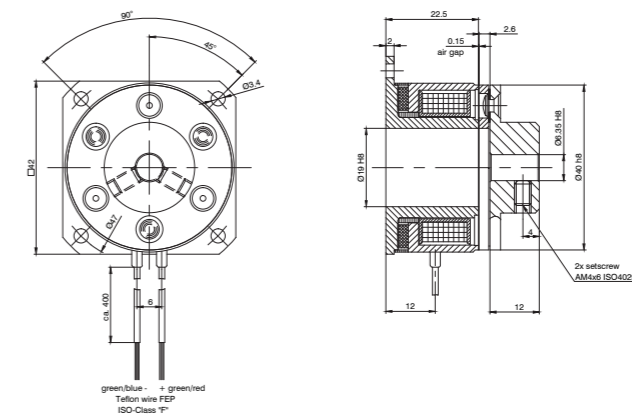

Lined area for notes with horizontal dotted lines.

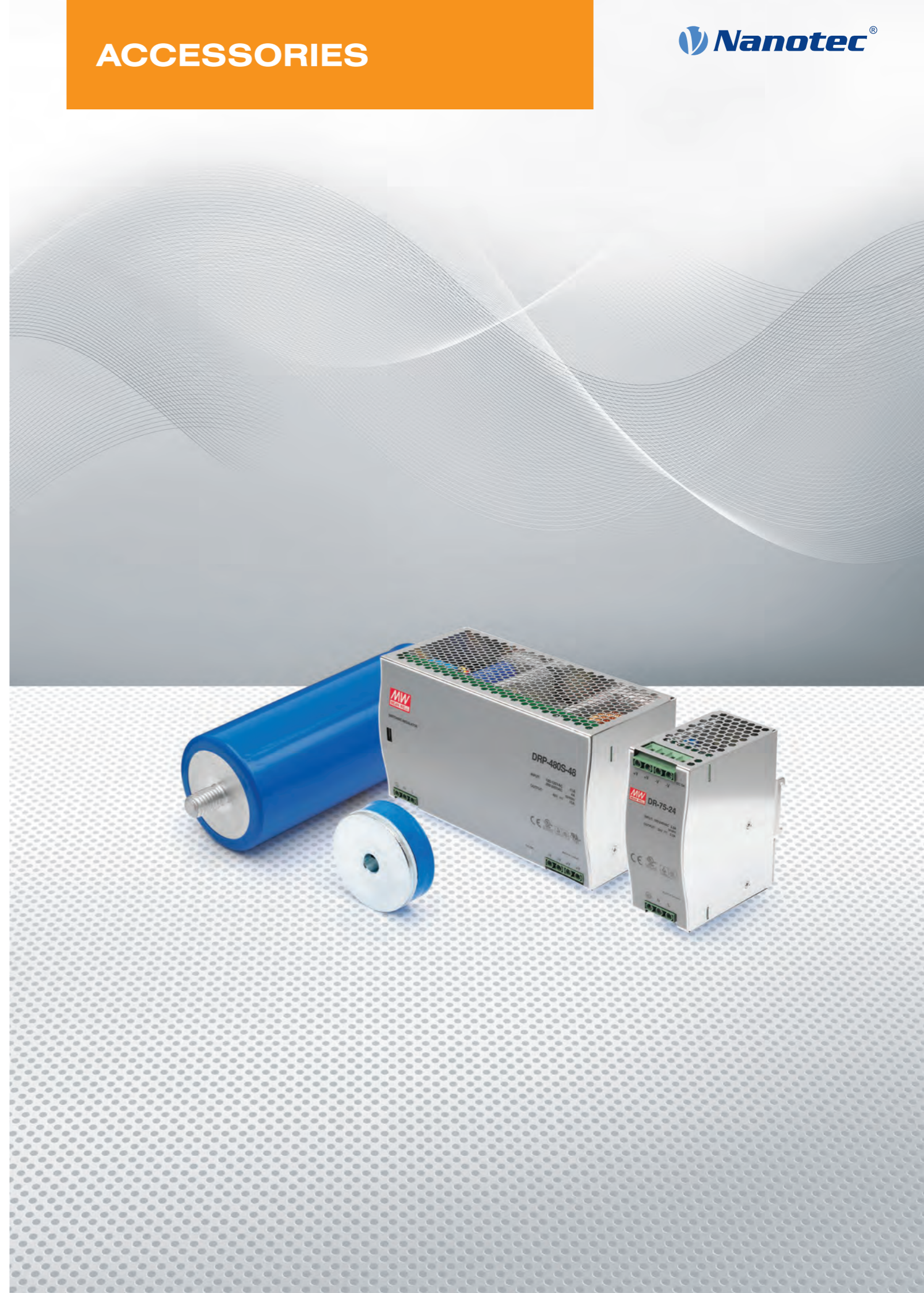

Threaded Nut

for Linear Actuators



ORDER IDENTIFIER

LSNUT_T3.5x1

VERSIONS

Type	Corresponding Motors
LSNUT_T3.5x1	L.....T3.5x1
LSNUT-T5x5-F	L.....T5x5
LSNUT-T6x1-F	L.....T6x1
LSNUT-T6x2-F	L.....T6x2
LSNUT-T10x2-F	L.....T10x2

DIMENSIONS (IN MM)

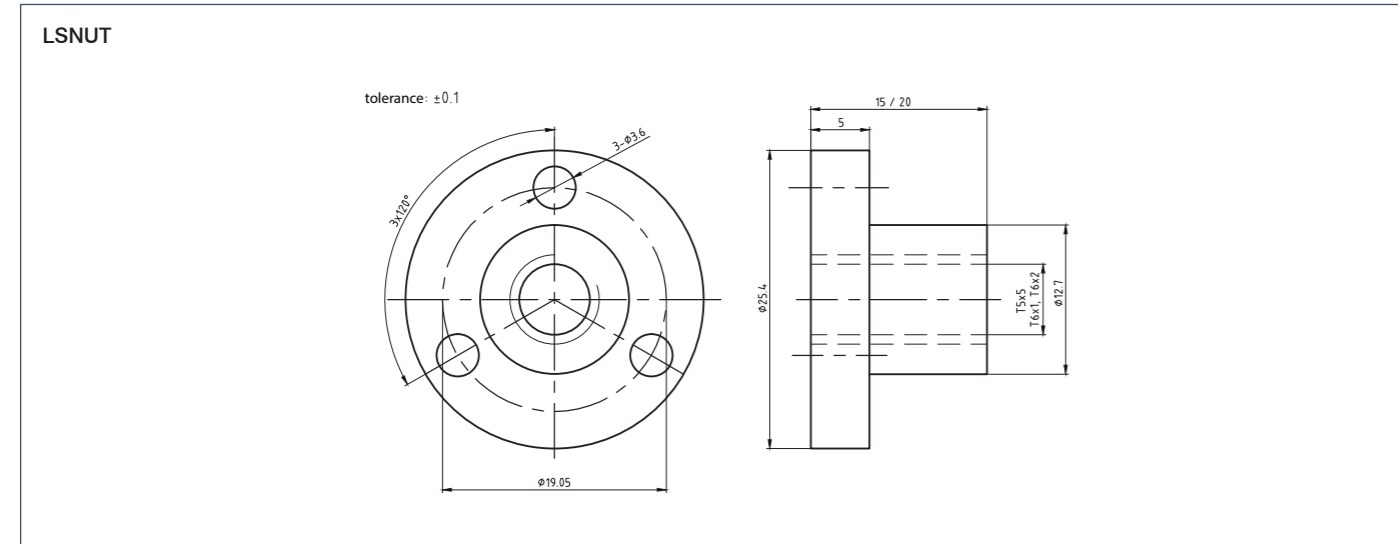

Threaded Nut

for Linear Actuators

DIMENSIONS (IN MM)

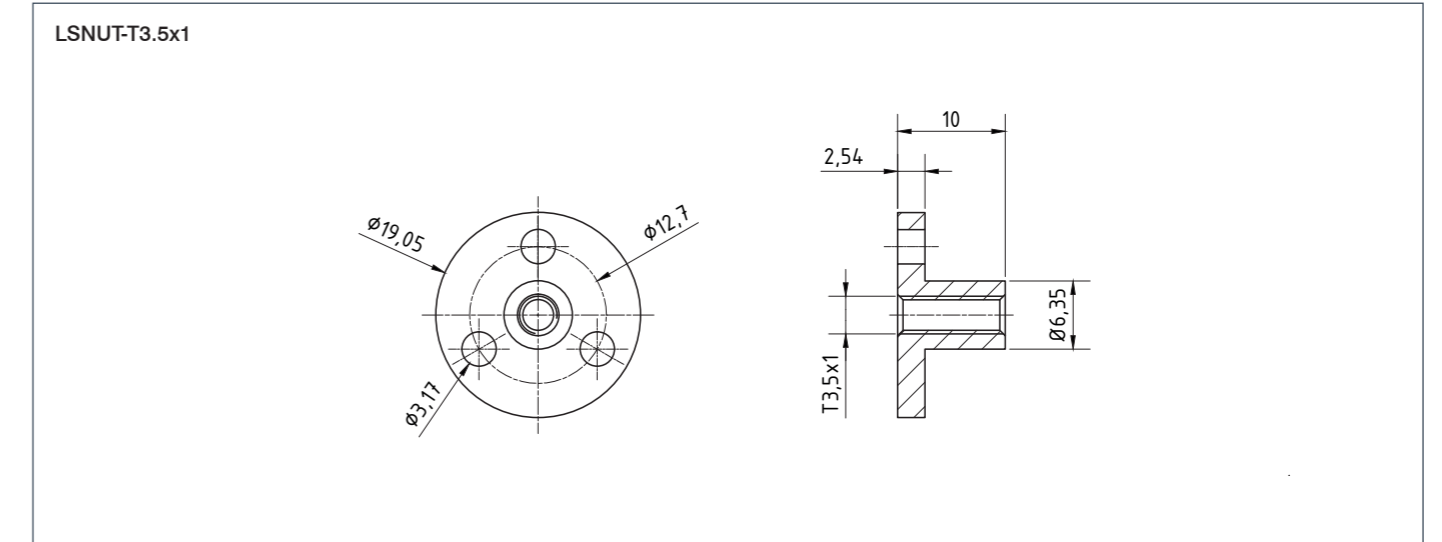
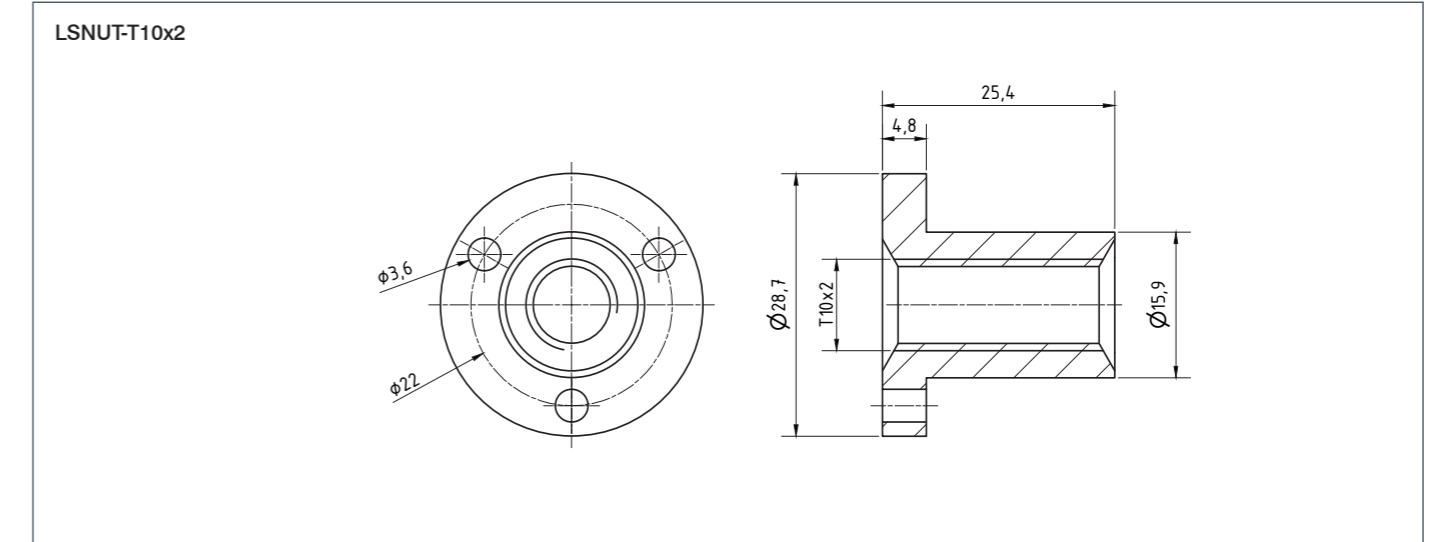



TECHNICAL DATA

Input voltage	180 VAC to 264 VAC
Output voltage	24 V, 48 V
Safety	Soft start
Protective circuit	Overload/overvoltage protection, over-bridging loss of power 20 ms below full load, short-circuit proof
Temperature range	- 10 °C to +50 °C (up to +70 °C at 60 % load)
Approvals	CE/UL/TÜV
Efficiency	86 %
Type of connection	Screw clamps
Fastening type	DIN carrying rail

VERSIONS

Type	Input Voltage V	Output Voltage V	Output current A	Power Output W	Weight kg
NTS-12V-3,5A	85...264VAC 120...370VDC	12	3,5	42	0,31
NTS-24V-2A	85...264VAC 120...370VDC	24	2	48	0,31
NTS-24V-3,2A	85...264VAC 120...370VDC	24	3,2	76,8	0,6
NTS-24V-5A	88...132/176...264VAC 248...370VDC	24	5	120	0,79
NTS-24V-10A	85...264VAC 120...370VDC	24	10	240	1,2
NTS-24V-20A	180...264	24	20	480	2,4
NTS-24V-40A	340...550VAC 3ph.	24	40	960	3,3
NTS-48V-2,5A	88...132/176...264VAC 248...370VDC	48	2,5	120	0,79
NTS-48V-5A	85...264VAC 120...370VDC	48	5	240	1,2
NTS-48V-10A	180...264 VAC 250...370 VAC	48	10	480	2,4
NTS-48V-20A	340...550VAC 3ph.	48	20	960	3,3

DIMENSIONS (IN MM)

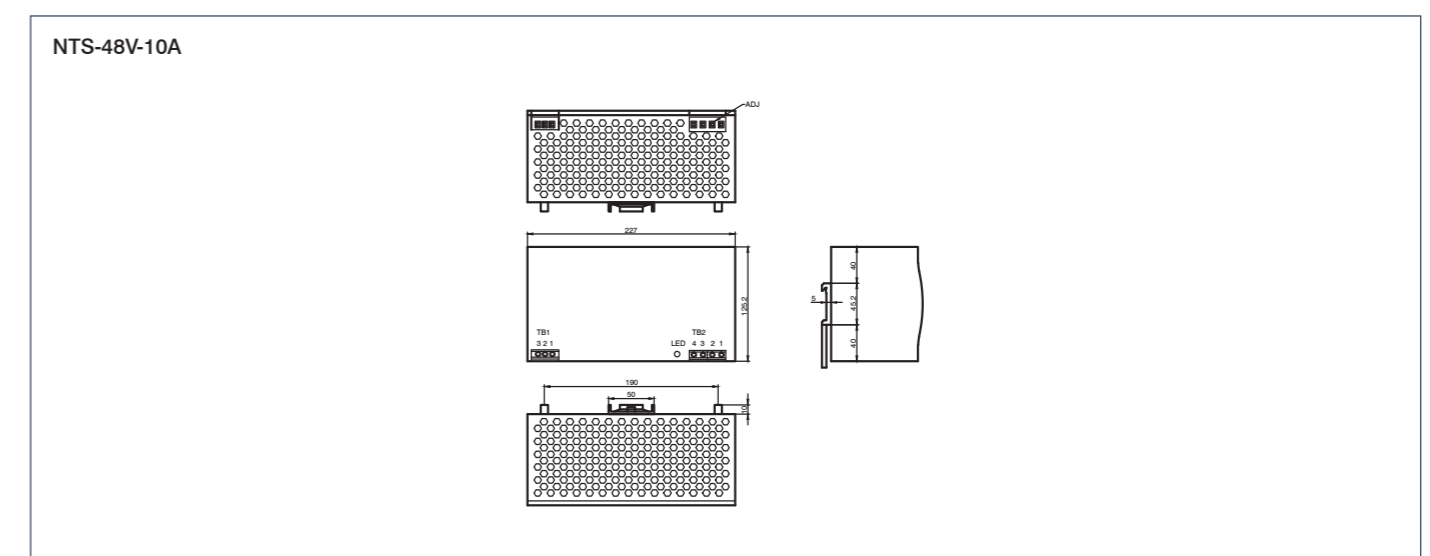
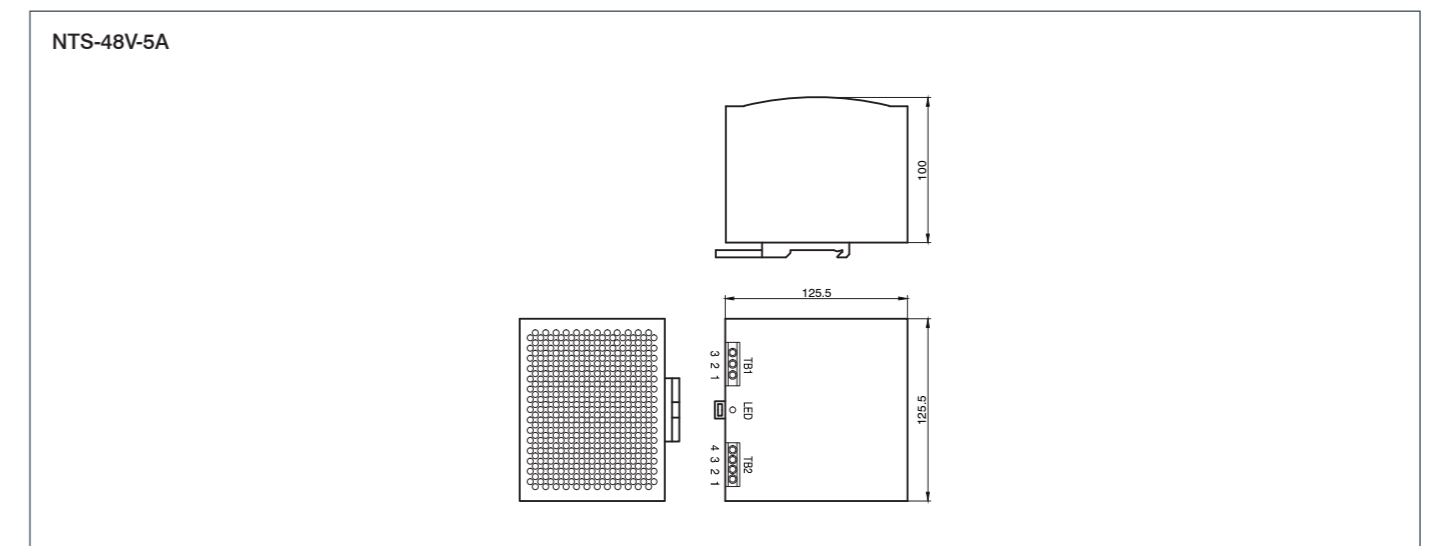
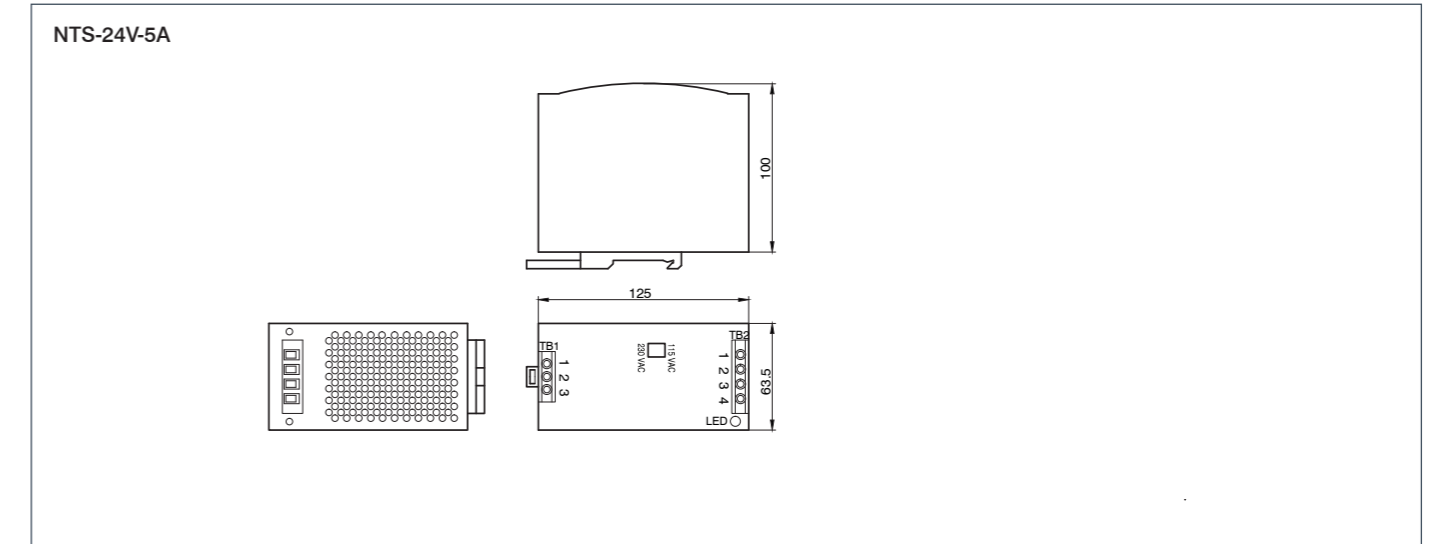



VERSIONS

Type	Suitable for	Cable Length
ZK-GHR3-500-S	CL3-E	0.5
ZK-GHR10-500-S-GHR	CL3-E	0.5
ZK-GHR12-500-S	CL3-E	0.5
ZK-GHR13-500-S-GHR	CL3-E	0.5
ZK-JST-EHR-6-0.5M-S	SC4118 Series	0.5
ZK-JST-EHR-6-2M-S	SC4118 Series	2
ZK-JST-PHR-6-0.3M	DF45	3
ZK-JST-VHR-5N-0.3M	DF45	3
ZK-JST-VHR-6N-0.5M-S	SC6018 Series	0.5
ZK-JST-VHR-6N-2M-S	SC6018 Series	2
ZK-MICROUSB	PD4-C	1.5
ZK-PD4N	PD4-N	0.5
ZK-PD2N	PD2-N4118L1804-3	-
ZK-PD2N-3	PD2-N4118L1804-3	-
ZK-PD4-C-CAN-4-500-S	PD4-C-CAN	0.5
ZK-SMC11	Cable Set for SMC11	0.3
ZK-SMC12	SMC12/PD2-O	-
ZK-SMC12-3	Cable Set for SMC12 with CANopen	0.15
ZK-SMC12-IO	SMC12/PD2-O (I/O and Power Only, Without D-SUB)	0.3
ZK-USB	Cable Set for SMC133-1	1.5
ZK-XHP-4-300	SMC12	0.3
ZK-XHP2-500-S	CL3-E	0.5
ZK-ZHR5-90	SMC135/SMC136 (ENC + HALL Connection Cable)	0.09
ZK-ZHR6-500	SMC135/SMC136 (IO Cable)	0.5



VERSIONS

Type	Description	Cable Length	IP Protection	Cable Type
ZK-NME1-13-500-S	Cable for NME1 Encoder	0.5	Shielded	Free Cable Ends
ZK-NOE-10-500-S-PADP	Cable for NOE1/NOE2	0.5	Shielded	Adaptercable
ZK-NOE1-10-2000-S	Cable for NOE1/NOE2	2	Shielded	Free Cable Ends
ZK-NOE1-10-500-S	Cable for NOE1/NOE2	0.5	Shielded	Free Cable Ends
ZK-PADP-12-500-S	Cable for Controller	0.5	Shielded	Flying Leads
ZK-SMCI-LD	Encoder with Line Driver for SMC133/47 (5 V)	0.175	Unshielded	Line Driver Converter
ZK-SMCI35-LD	Encoder with Line Driver for SMC135/36	0.175	Unshielded	Line Driver Converter
ZK-WEDL-8-1000-S	Cable for WEDL5541	1	Shielded	Free Cable Ends
ZK-WEDL-8-2000-S	Cable for WEDL5541	2	Shielded	Free Cable Ends
ZK-WEDL-8-500	Flat-band Cable WEDL5541	0.5	Unshielded	Free Cable Ends
ZK-WEDL-8-500-S	Cable for WEDL5541	0.5	Shielded	Free Cable Ends
ZK-WEDS-300-S-SMC135	Cable for WEDS5541	0.3	Shielded	ZHR5 Connector
ZK-WEDS-5-150-S	Cable for WEDS5541	0.15	Shielded	Free Cable Ends
ZK-WEDS-5-500	Flat-band Cable for WEDS5541	0.5	Unshielded	Free Cable Ends
ZK-WEDS-5-500-S	Cable for WEDS5541	0.5	Shielded	Free Cable Ends



VERSIONS

Type	Number of Poles	Cable Length	Plug Type	IP Protection
ZK-M8-3-2M-1-PUR-S	3	2	Straight	Shielded
ZK-M8-3-5M-1-PUR-S	3	5	Straight	Shielded



VERSIONS

Type	Suitable for	Number of Poles	Cable Length	Plug Type
ZK-M12-12-2M-1-PUR-S	ASB42	12	2	Straight
ZK-M12-12-5M-1-PUR-S	ASB42	12	5	Straight
ZK-M12-12-2M-2-PUR-S	ASB42	12	2	Angled
ZK-M12-12-5M-2-PUR-S	ASB42	12	5	Angled
ZK-M12-17-1M-2-S-FIN	PD2-N4118-IP	17	1.5	Angled
ZK-M12-8-2M-1-PUR-S	AS Motors with Encoder	8	2	Straight
ZK-M12-8-5M-1-PUR-S	AS Motors with Encoder	8	5	Straight
ZK-M12-8-2M-2-PUR-S	AS Motors with Encoder	8	2	Angled
ZK-M12-8-2M-2-PADP	ASB Motors to Controller	8	5	Angled
ZK-M12-8-5M-2-PUR-S	AS Motors with Encoder	8	5	Angled
ZK-M12-5-2M-1-PUR-S	AS Motors, PD2 IP and PD4 IP	5	2	Straight
ZK-M12-5-5M-1-PUR-S	AS Motors, PD2 IP and PD4 IP	5	5	Straight
ZK-M12-5-2M-2-PUR-S	AS Motors, PD2 IP and PD4 IP	5	2	Angled
ZK-M12-5-5M-2-PUR-S	AS Motors, PD2 IP and PD4 IP	5	5	Angled
ZK-M12-12-2M-2-PADP	AS Motors to Controller	12	2	Angled
ZK-M12-17-1M-2-PUR-S	PD2-IP and PD4-IP	17	1.5	Angled
ZK-M12-17-3M-2-PUR-S	PD2-IP and PD4-IP	17	3	Angled



VERSIONS

Type	Suitable for	Number of Poles	Cable Length	Cable Type
ZK-TW-3-2M	PD6-N8918...-S	3	2	Motor Cable
ZK-TW-3-5M	PD6-N8918...-S	3	5	Motor Cable
ZK-TW-3-10M	PD6-N8918...-S	3	10	Motor Cable
ZK-TW-3-2M-2	PD6-N8918...-S	3	2	Motor Cable
ZK-TW-3-5M-2	PD6-N8918...-S	3	5	Motor Cable
ZK-TW-3-10M-2	PD6-N8918...-S	3	10	Motor Cable
ZK-TW-7-2M	AS8918	7	2	Motor Cable
ZK-TW-18-2M	PD6-N8918...-S	18	2	Signal Cable
ZK-TW-18-5M	PD6-N8918...-S	18	5	Signal Cable
ZK-TW-18-10M	PD6-N8918...-S	18	10	Signal Cable
ZK-TW-18-2M-2	PD6-N8918...-S	18	2	Signal Cable
ZK-TW-18-5M-2	PD6-N8918...-S	18	5	Signal Cable
ZK-TW-18-10M-2	PD6-N8918...-S	18	10	Signal Cable
ZK-TW-4-2M	ASB42	7	2	Motor Cable



VERSIONS

Type	Number of Poles	Cable Length	Cable Type
ZK-JST-VL-4	4	2	for JST XHP-4 Connector
ZK-JST-VL-6	6	2	for JST XHP-6 Connector



DESCRIPTION

The **Nano brake module** (PWM controller) not only reduces power and heat loss by 35%, but also extends motor life and activation times.

With the additional **ZIB-PD6-N** board, wiring Plug & Drive PD6-N motors is no longer a time-consuming task. Test board **ZIB2** can be used to quickly and easily commission Nanotec motor controllers and Plug & Drives. Additional LEDs and buttons serve to test and monitor the functions of the digital inputs and outputs. As well, signals can be conducted directly to external sensors and actuators via the connecting terminal. The board is not intended for permanent installation in machines.

VERSIONS

Type	Type	Max. Operating Voltage V	Dimensions
EB-Brake	PWM Controller for Brakes	24	25.4 x 12.5 mm
ZIB-PDx-N	Add-on Board for PD6-N Motors	24 - 48	45 x 110 mm
ZIB2-PDx-N	Interface Board Plug&Drive and SMCI Controller	24 - 48	100 x 130 mm



VERSIONS

Type	Description
ZCJST-XHP	Connector socket housing
ZCJST-SXH	Contacts for connector socket housing
ZCJST-XHP	Insulation displacement connection technology, connector for AWG24
ZC2	Pin connector for print installation RM 2.54 mm
ZCPHOFK-MC0,5	COMBICON connector socket housing
ZCPHOFKC-2,5HC	COMBICON HC connector socket housing

ORDER IDENTIFIER



ZCJST-XHP-
 2 = 2 Pin configuration
 3 = 3 Pin configuration
 4 = 4 Pin configuration
 5 = 5 Pin configuration
 6 = 6 Pin configuration
 8 = 8 Pin configuration

CAUTION



For mounting the connector, please use a crimping tool, e.g. JST WC-110.

Charging Capacitor

for SMC and PDx-I



VERSIONS

Type	Capacity µF	Max. Operating Voltage V	Temperature Range °C	Capacitance Tolerance	Grid Dimensions mm	Dimensions
Z-K4700/50	4700	50	-40 to +85	± 20%	10	Cylindrical aluminum cup, Ø 25 mm, 35 mm length
Z-K10000/100	10000	100	-40 to +105	-10% ~ 30%	20	Cylindrical aluminum cup, Ø 40 mm, 95 mm length

ORDER IDENTIFIER



Z-K4700/50

DIMENSIONS (IN MM)

Z-K10000-100

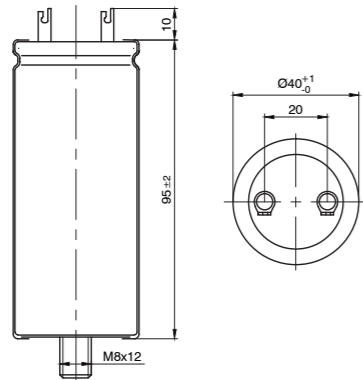

Charging Capacitor

for SMC and PDx-I



DIMENSIONS (IN MM)

Z-K4700-50

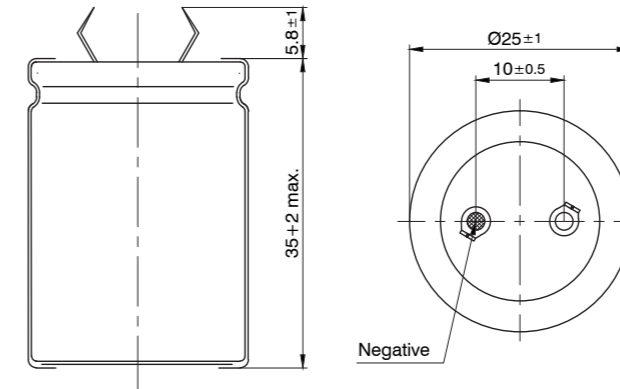



ORDER IDENTIFIER

ZD-D28

DESCRIPTION

The dampers D40, D56 and D56m from Nanotec can be installed on all stepper motors with a double shaft (size 40 – 58mm). Alongside the improved settling time, system resonances are suppressed, and vibrations and motor noises at lower speeds are greatly reduced.

In case of device-specific resonance and noise problems, device setup is made considerably easier by mounting a damper.

VERSIONS

Type	Corresponding Motors	Shaft Diameter mm	Weight kg
ZD-D28	ST28, ST35	5	0.026
ZD-D40	ST41, ST42	5	0.04
ZD-D56	ST59	6.35	0.1

DIMENSIONS (IN MM)

ZD-D28

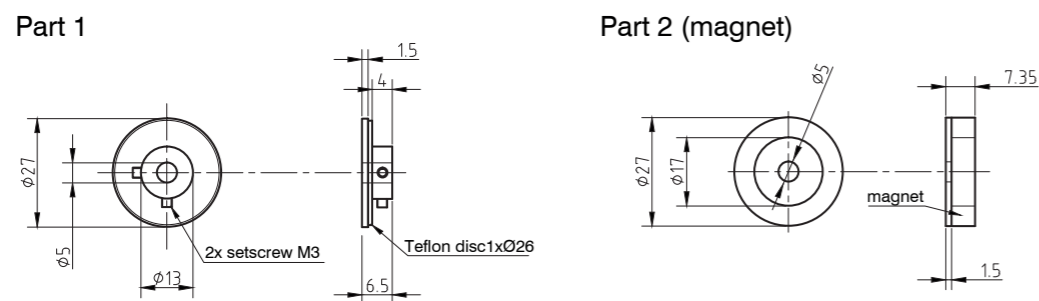

DIMENSIONS (IN MM)

ZD-D40

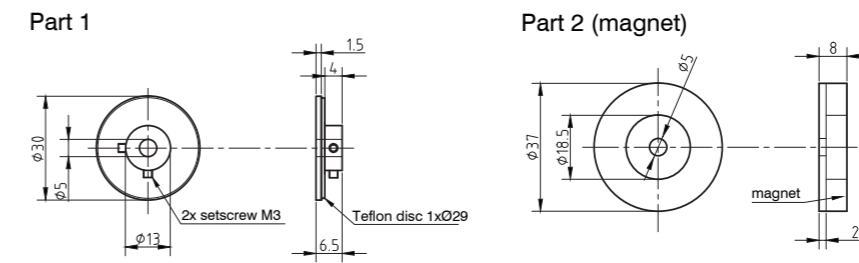

ZD-D56

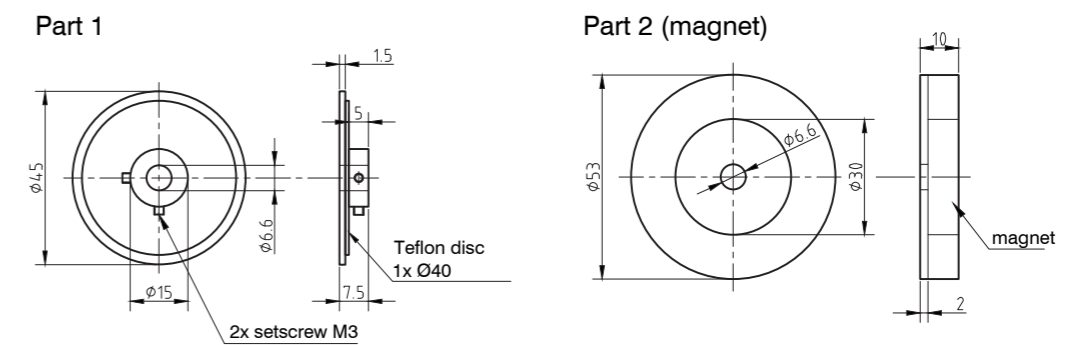

Damper

for Mounting Flange



ORDER IDENTIFIER

ZD-DF40

DESCRIPTION

The vulcanized rubber between the two flange rings in ZD-... dampers serves first and foremost to suppress rigid-body sound. Depending on the frequency, sound can be reduced by 3–10 dB(A). The ZD-... damper cost-effectively attenuates noise due to the different sound speeds of steel/air/rubber (5000/331/50 m/s) and its damping oscillation tendency.

VERSIONS

Type	Corresponding Motors
ZD-DF40	ST41, ST42
ZD-DF56	ST59

DIMENSIONS (IN MM)

ZD-DF40

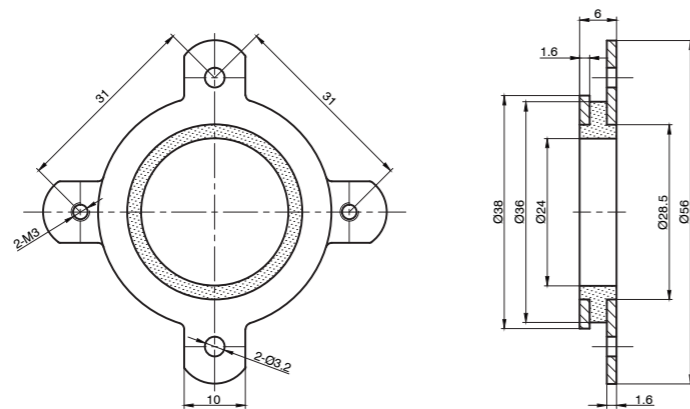

Damper

for Mounting Flange

DIMENSIONS (IN MM)

ZD-DF56

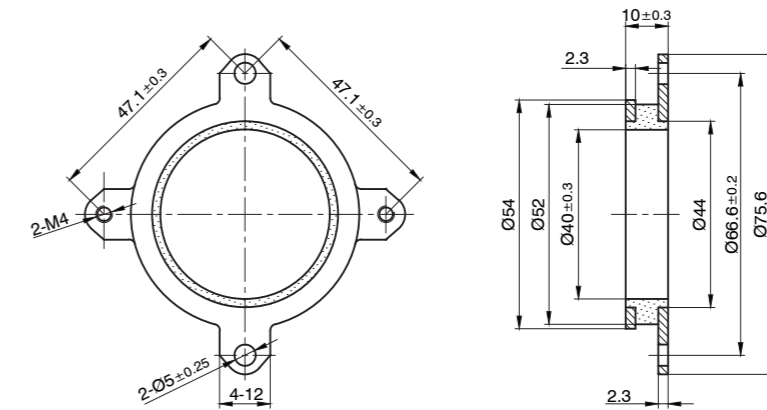

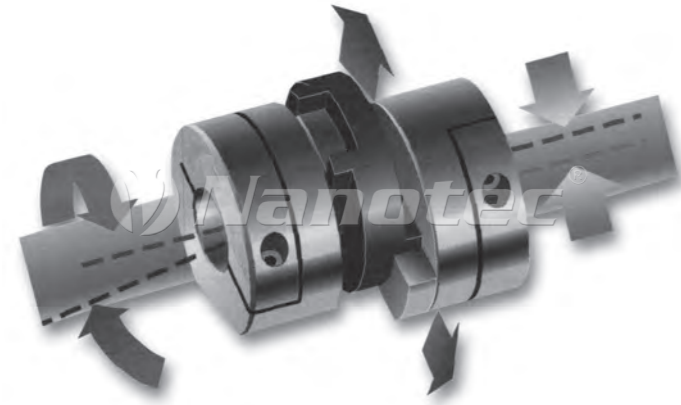

TECHNICAL DATA

Temperature range	-20 to +60 °C
Materials	Hub of aluminum alloy 2011T3 and 2011T8 BS4300/5FC1
Transmission disc	Nylon 11 (colorless)
Tapped blind hole	Length of the parallel borehole ± 0.2 . Boreholes end with 118 ° bevel
Operating factors	See data sheet

ORDER IDENTIFIER



ZW-235-19-20
(with a min. order of 50 pcs, custom specific boreholes are possible!)

CAUTION



The couplings from Nanotec are also available without hub hole for installation by the customer. Always order two couplings and one transmission disc.

VERSIONS

Type	Description
ZW-234-19-20	Shaft Coupling
ZW-234-19-0	Transmission Disc
ZW-234-25-24	Shaft Coupling
ZW-234-25-0	Transmission Disc
ZW-234-41-38	Shaft Coupling
ZW-234-41-0	Transmission Disc

DIMENSIONS (IN MM)

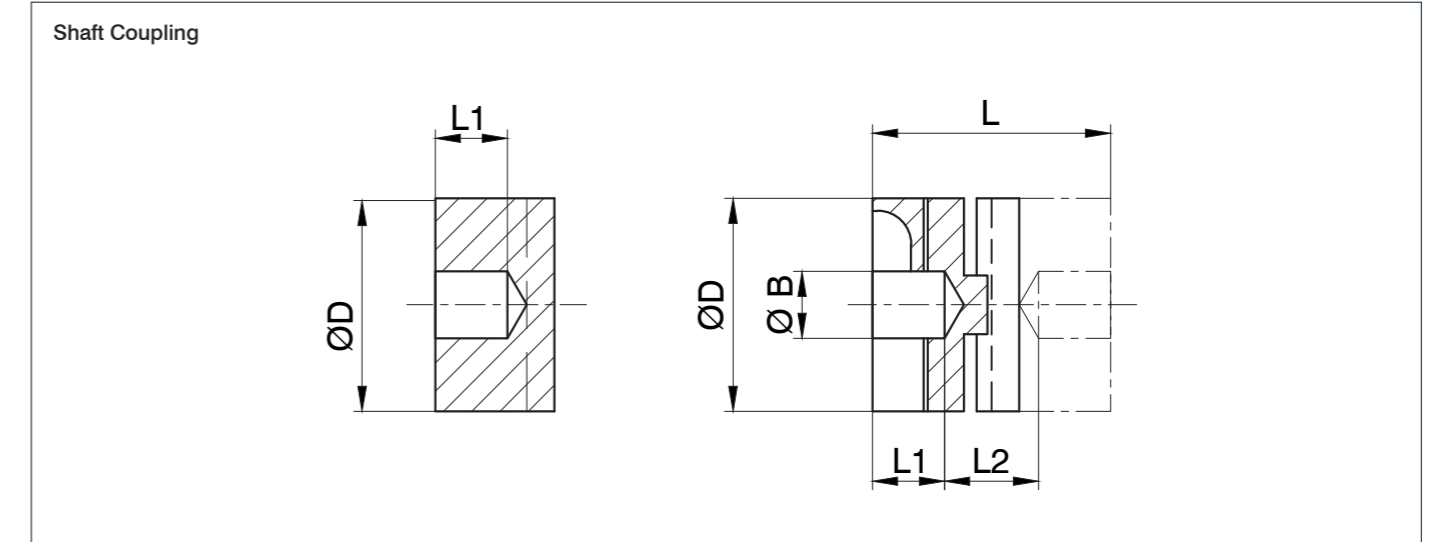

EUROPE:

Nanotec Electronic GmbH & Co. KG
Kapellenstraße 6
85622 Feldkirchen/Munich, Germany

Phone: +49 (0) 89 900 686-0
Fax: +49 (0) 89 900 686-50
E-mail: info@nanotec.de

NORTH AMERICA:

Nanotec Electronic, U.S., Inc.
98 Sheridan Avenue
Medford, MA 02155 USA

Phone: +1 781 219 33 43
Fax: +1 781 498 13 44
E-mail: info@us.nanotec.com

ASIA:

Nanotec Electronics (ChangZhou) Co., Ltd.
Building 1,18 QingJiang Road, New District
ChangZhou City, JiangSu Province
P.R. China 213022

Phone: +86 519 830 211 77
Fax: +86 519 830 211 17
E-mail: info@cn.nanotec.com