



**isel**<sup>®</sup> *From Components to Systems*

# AUTOMATION



MECHANICS



ELECTRONICS



SOFTWARE



SYSTEMS



DISPLAY



LIFESTYLE

*...for best quality and price...*



	GENERAL	
	MECHANICS	
	ELECTRONICS	
	SOFTWARE	
	SYSTEMS	

**Business hours****Dermbach plant**

sales, order processing and registry

Monday–Thursday 7:30 a.m. – 4:30 p.m.  
Friday 7:30 a.m. – 2 p.m.**Eichenzell plant**

shipping and receiving

Monday–Thursday 7 a.m. – 3 p.m.  
Friday 7 a.m. – 12:30 p.m.**Eichenzell plant**

Personal collection

Monday–Thursday 8 a.m. - 1 p.m.  
Friday 8 a.m. - 11 a.m.**Switchboard**phone: +49(0) 6659 / 981-700  
telefax: +49 (0) 6659 / 981-776  
email: automation@isel.com**Shipment  
national and international**phone: +49(0) 6659 / 981-790  
telefax: +49(0) 6659 / 981-782  
email: versand@isel.comDoreen Goepfert -741  
Ingo Giebel -746**Accounts receivable department**phone: +49(0) 6659 / 981-154  
Telefax: +49(0) 6672 / 898-195  
email: debitoren@isel.com

Doris Wolf

**Sales and consultancy**phone: +49(0) 6659 / 981-790  
telefax: +49(0) 6659 / 981-777  
email: tech-sales@isel.comJürgen Balzer     Stefan Koch  
Steffan Gärrh     Christian Bley  
Felix Hohmann     Volker Zulauf  
Janina Fischer     Katja Henkel  
Jessica Gatterdam  
Andreas Trabert (Sales manager)**Customer support**phone: +49(0) 6659 / 981-790  
telefax: +49(0) 6659 / 981-570  
email: support@isel.comFrank Hecht  
Frank Jansen  
Anna Mähler  
Fred Reinhard (Support manager)**Anwendungstechnik**phone: +49(0) 6659 / 981-790  
telefax: +49(0) 6659 / 981-564  
email: anwendungstechnik@isel.comThomas Grammlich  
Mike Witzmann  
Andreas Schaub (Application manager)**isel Germany AG**Bürgermeister-Ebert-Straße 40 | D-36124 Eichenzell | phone +49 (0) 6659 / 981-700 | telefax +49 (0) 6659 / 981-776  
email: automation@isel.com | www.isel.com



To our business partners

Today we are sending you our new "Automation" catalogue, combined with a thank you for your interest in the isel product range. The isel corporate group has been active in the automation market for over 40 years and we are keen to help our customers achieve long-term success.

#### **New aluminium profiles for a host of different applications**

In the last product catalogue, the aluminium profiles were missing. In the area of aluminium profiles, our designers have now developed more than 90 new profiles with the profile range "Alu-T-profiles", marked particular by their lightweight construction and reasonable price. Extensive accessories complete the range. We have therefore created a separate sub-catalogue for these numerous new profiles.

#### **New engine types to meet customised solutions with lot size 1**

Our customers are increasingly demanding full solutions and this trend presents us with steadily growing requirements in the field of special machine construction in lot size 1. To be even more flexible, we have extended the isel product range to include high-quality servo-drive motors. Higher accuracy, better dynamics, and higher protection classes for more specific environments are the result of this change.

#### **ERP system improved - greater transparency**

We have extensively updated our merchandise management system and the benefits for you are even more precise delivery dates and greater regarding all processes within the company. Delivery deadlines were clearly improved by this measure last year.

#### **B2B-Shop**

The isel on-line shop has also been further developed over the past year; with an improved search engine helping you find the products you want even faster. It is now also possible to pay for the goods ordered by PayPal and the on-line shop reflects the state of the art in media technology.

#### **Even more trade fairs in 2016**

To enhance dialogue with our customers, we took part in quite a few more trade fairs in 2016 than in the previous years. We really hit the "spirit of the times" with a straightforward stand at the shows. The Internet does offer a host of different ways to get information about the required product, but direct contact with customers and prospective customers has proven to be equally as important and correct.

#### **New technology partners**

Over the last few years, we have built up a network of technology partners to facilitate the development of the growing variety of individual customer applications. These partners add to our expertise and in turn benefit from our knowledge. Numerous projects in the fields of lasers, dispensing and milling have been successfully completed with the help of many years of experience from our partners and this year we will also have the assistance of partners from the areas of 3D printing and plasma cutting.

#### **Profiting together**

Achieving success together in the long term means that we also support you above and beyond sales. Isel Germany AG constantly strives to provide you with high-quality products, to guide you in the completion of your individual projects and to incorporate your suggestions into our developments.

If you have any questions that our catalogue has not covered, do not hesitate to contact our sales team.

We look forward to an interesting and successful year with you!

**Andreas Trabert**

Sales manager  
isel Germany AG

# isel Group locations in Germany



**Plant Eiterfeld**  
36132 Eiterfeld, Hesse  
total space: approx. 53,000 m<sup>2</sup>



**Plant Eichenzell**  
36124 Eichenzell, Hesse  
total space: approx. 35,000 m<sup>2</sup>



**Plant Dermbach**  
36466 Dermbach, Thuringia  
total space: approx. 41,000 m<sup>2</sup>



**Plant Berlin**  
13627 Berlin-Charlottenburg  
total space: approx. 22,000 m<sup>2</sup>

# Contents

## GENERAL

Contact .....	A-2
Welcome .....	A-3
Locations.....	A-4
Corporate philosophy .....	A-5
How to find us.....	A-6
Subsidiaries .....	A-7
Application Center.....	A-8
Reference .....	A-9
Quality assurance .....	A-10

## MECHANICS

Aluminium profile .....	B-2
Linear guides .....	B-4
Drive elements .....	B-26
Linear units .....	B-34
Rotational units .....	B-72

## ELECTRONICS

Controllers .....	C-2
-------------------	-----

## SOFTWARE

CAD / CAM .....	D-4
Interpreter software .....	D-6
Programming software .....	D-7

## SYSTEMS

Life Cycle Service.....	E-5
CNC machines .....	E-7
Machine configuration .....	E-20
Accessories .....	E-22
Robotics .....	E-48

## The isel-Group

The international [isel group of companies](#) was founded in 1972 as a one-man operation in Eiterfeld (Hesse) under the company name isert electronics. The company dealt with the manufacture and distribution of equipment "around the conductor board" in the first few years. Object of the company today is the development, production, sales and service of components and systems for automation.

The product range from components to systems made by isel includes CNC units, CNC machines, automation, handling and robotics with step, servo, linear and torque motors including controls.

Members in Germany are the companies isel GmbH & Co.KG, **isel Germany AG**, imes-icore GmbH and isel Facility GmbH. Other offices are located in Austria, Hungaria, France, Great Britain and the USA.

### isel Germany AG

The **isel Germany AG** is a hundred percent company of the isel group and located in Germany in Eichenzell (Hesse) and Dermbach (Thuringia) with a total of **25,000 m<sup>2</sup>** of production, warehouse and office space.

Main area of business of the isel Germany AG is the provision of components from MECHANICS, ELECTRONICS and SOFTWARE. Furthermore CNC units and CNC machines are available with extensive accessories. This includes also commissioned work and project planning for OEM customers in all sectors.

In addition to an expert advice, the isel Germany AG also offers services like trainings and project planning.

Benefit from our years of experience on the market! We deliver from components to system from a single source.

Technical data is accurate to the best of our knowledge and belief. Future developments are subject to change without notice. This catalogue supersedes all previous versions.

# How to find us

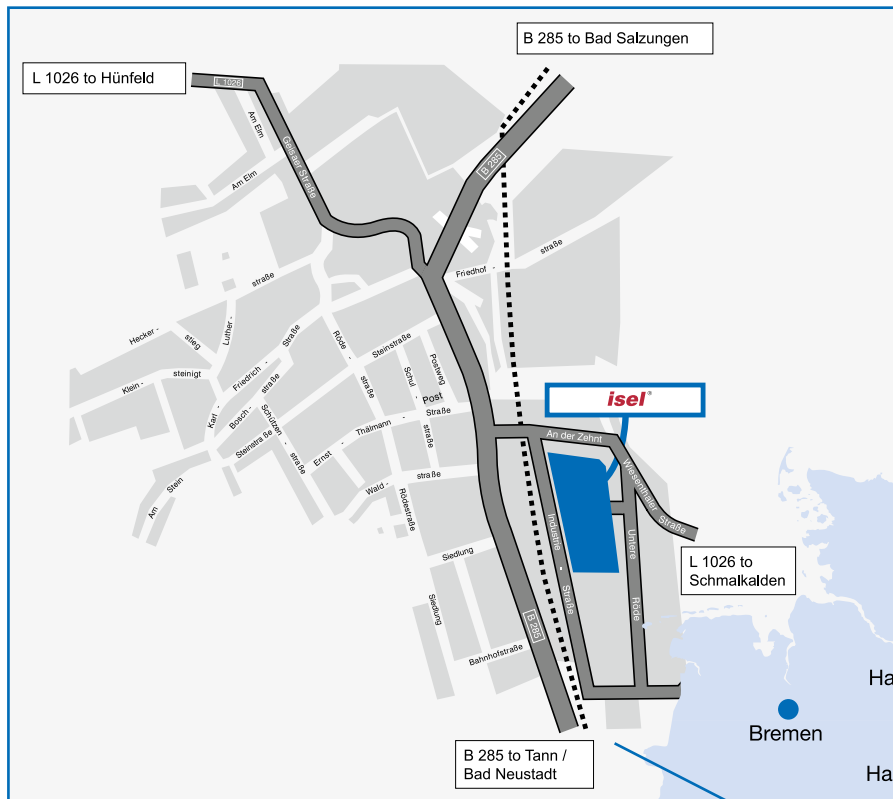

You can find us in the heart of Germany.

Dermbach is located at the B 285 between Bad Neustadt/ Saale and Bad Salzungen, respectively at the L 1026 between Hünfeld and Schmalkalden.

Dermbach

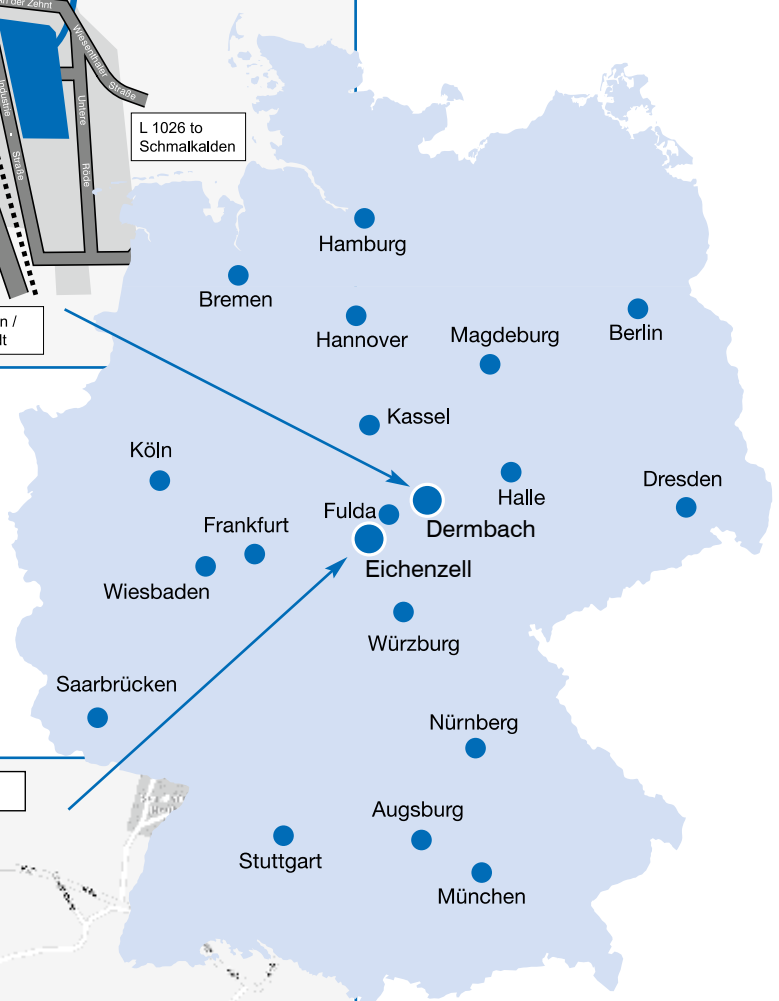

Eichenzell

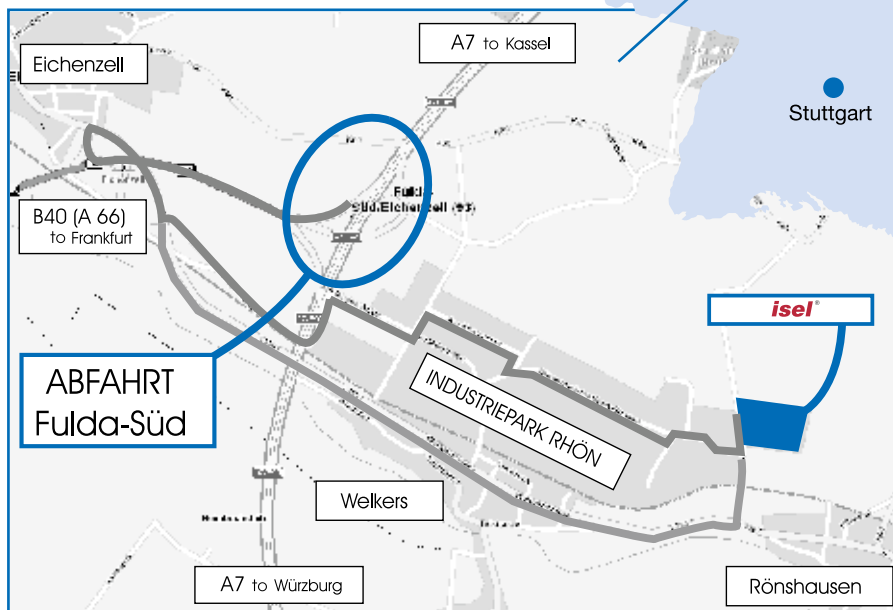

Eichenzell is located at the A7 between Kassel and Würzburg, exit Fulda-Süd, if you are coming from Frankfurt at the A 66/B 40.



## Subsidiaries international



### **isel**Austria

isel Austria GmbH & Co.KG  
Maria Theresia-Str. 53 / 1.1  
4600 Wels / Austria

Phone: +43 (0) 7242 206829  
Telefax: +43 (0) 7242 211445

Website: [www.isel.com/at/](http://www.isel.com/at/)  
Mail: [info@isel-austria.com](mailto:info@isel-austria.com)

**Sales for:**

GUS states (Russia), Poland, Estonia, Latvia, Lithuania, Ukraine, Belarus, Moldova, Kazakhstan and Georgia



### **isel**Hungária

isel Hungaria Kft.  
József A. utca 38  
H-8200 Veszprém

Phone: +36 (0) 88 406 682  
Telefax: +36 (0) 88 406 681

Website: [www.isel.hu](http://www.isel.hu)  
Mail: [iselhungaria@isel.hu](mailto:iselhungaria@isel.hu)

**Sales for:**

Bulgaria, Serbia, Montenegro, Bosnia and Herzegovina, Croatia, Slovenia, Slovakia, Czech Republic and Romania



### **isel**France

isel-France  
ZAC de la Prévaute  
4, Rue des Côtes d'Orval BP41  
F-78550 Houdan

Phone: +33 (0) 130 461 201  
Telefax: +33 (0) 130 596 932

Website: [www.isel.fr](http://www.isel.fr)  
Mail: [info@isel.fr](mailto:info@isel.fr)

**Sales for:**

France



### **isel**UK

isel UK Ltd.  
Unit 17 | Maylands Business Centre  
Redbourn Road  
Hemel Hempstead | HP2 7ES  
United Kingdom

Phone: +44 (0) 1442 531 225  
Mobil: +44 (0) 7821 761 517

Website: [www.isel.com/uk/](http://www.isel.com/uk/)  
Mail: [info@isel-uk.com](mailto:info@isel-uk.com)

**Sales for:**

Great Britain and Ireland



### **isel**USA

isel USA, Inc.  
69 Bloomingdale Road  
USA, Hicksville, New York 11801

Phone: 001-516-595-7497

Website: [www.techno-isel.com](http://www.techno-isel.com)  
Mail: [George.klein@isel.com](mailto:George.klein@isel.com)  
[Joseph.Griffin@isel.com](mailto:Joseph.Griffin@isel.com)

**Sales for:**

USA, Mexico and Canada

# Application Center



Visit our factory in Dermbach, Thuringia and convince yourself on-site of the efficiency of our cnc machines. We like to draw your attention to present a cross-section of our range of products, furthermore we offer you the opportunity of practically orientated demonstrations.

Do you have any questions regarding specific topics concerning particular applications?  
Don't hesitate to arrange an appointment with our applications technologist **Andreas Schaub**.

Mr. Andreas Schaub  
phone: +49 (0) 36964 / 84 525  
anwendungstechnik@isel.com

In our showroom, you`ll find the following machines:

- OverHead
- FlatCom XL
- EuroMod
- ICP 4030 und ICV 4030



# References

In the same way as our services are different, so are the customers and projects we plan and realize for you. A small selection of our references shown here:



Daimler AG



Daimler AG



# Quality assurance according to DIN ISO 9001:2008

The quality assurance system for our products comprises all areas which contribute to achieving the quality goals. It is based on legal requirements, customer requirements and the internal isel Germany AG quality requirements. The quality assurance system ensures the production processes are manageable and that products are only sent on to the next production step if they meet the respective specifications. We are certified according to DIN ISO 9001:2008.



## Coordinate measuring equipment

### Mitutoyo CRYSTA Apex S 123010

Specifications: X-axis = 1,205 mm  
Y-axis = 3,005 mm  
Z-axis = 1,005 mm  
Touch system: TP 200  
Changer magazin: SCR 200  
Length measuring deviation:  
MPE =  $(2,5 + 4,0L/1000)\mu\text{m}$



### Mitutoyo Euro C 544 Apex

Specifications: X-axis = 500 mm  
Y-axis = 400 mm  
Z-axis = 400 mm  
Touch system: TP 200  
Changer magazin: SCR 200  
Length measuring deviation:  
MPE =  $(2,9 + 4,0L/1000)\mu\text{m}$



### Mitutoyo Euro C 574 Apex

Specifications: X-axis = 500 mm  
Y-axis = 700 mm  
Z-axis = 400 mm  
Touch system: TP 200  
Changer magazin: SCR 200  
Length measuring deviation:  
MPE =  $(2,9 + 4,0L/1000)\mu\text{m}$

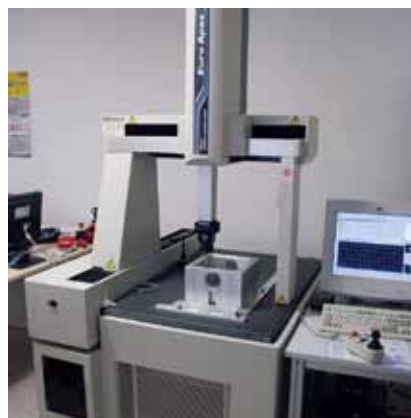

Technical specifications subject to change.

## ... and the quality requirements of our customers and isel Germany AG



**Surface roughness tester**  
**Mitutoyo**

**Type: SJ - 201 P**

Test procedure: Ra, Ry, Rz, Rq, Rt



**Hardness tester**  
**Wolpert**

**Type: Dia**  
**Testor 2 Rc**

Test procedure: Vickers,  
Brinell and Rockwell



**Layer thickness measurement device**  
**Elektro Physik**

**Type: Minitest 600 B**

Probe for iron and non-iron measurements.

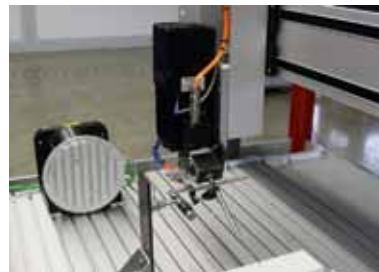
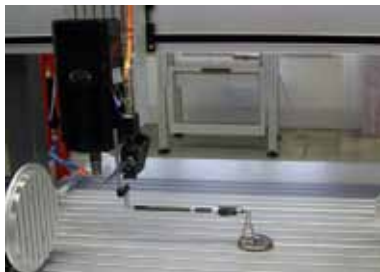

The QC 20 system allows the routine inspection of our machines. The measurement of the circularity detects geometric and control machine faults such as for example squareness, contouring errors, guide clearance, straightness faults and backlash. The system is traceable and is checked by the manufacturer on a regular basis.

## XL-80 Laser Interferometer

### ... position measurement

Position measurement is the most common measurement performed on machines. The system captures the positioning and repeat accuracy by comparing the position value indicated by the machine and the actual position captured by the Laser Interferometer System.

### ... tilt angle measurement

On machine tools and coordinate measuring equipment the cause for positioning faults is oftentimes the tilt of the axis. With the Abbe effect the faults continue to increase with an increasing distance from the axle location.

### ... Measuring the dynamic behaviour

The software for dynamic measurements allows for motion sequences, speeds, accelerations, vibrations and the capabilities of servo drives to be determined.

### ... Measuring the straightness

The straightness measurement is used to determine the horizontal and vertical straightness of the guide of the machine. Straightness errors have a direct influence on the positioning and the path accuracy of the machine.



Technical specifications subject to change.

# mechan

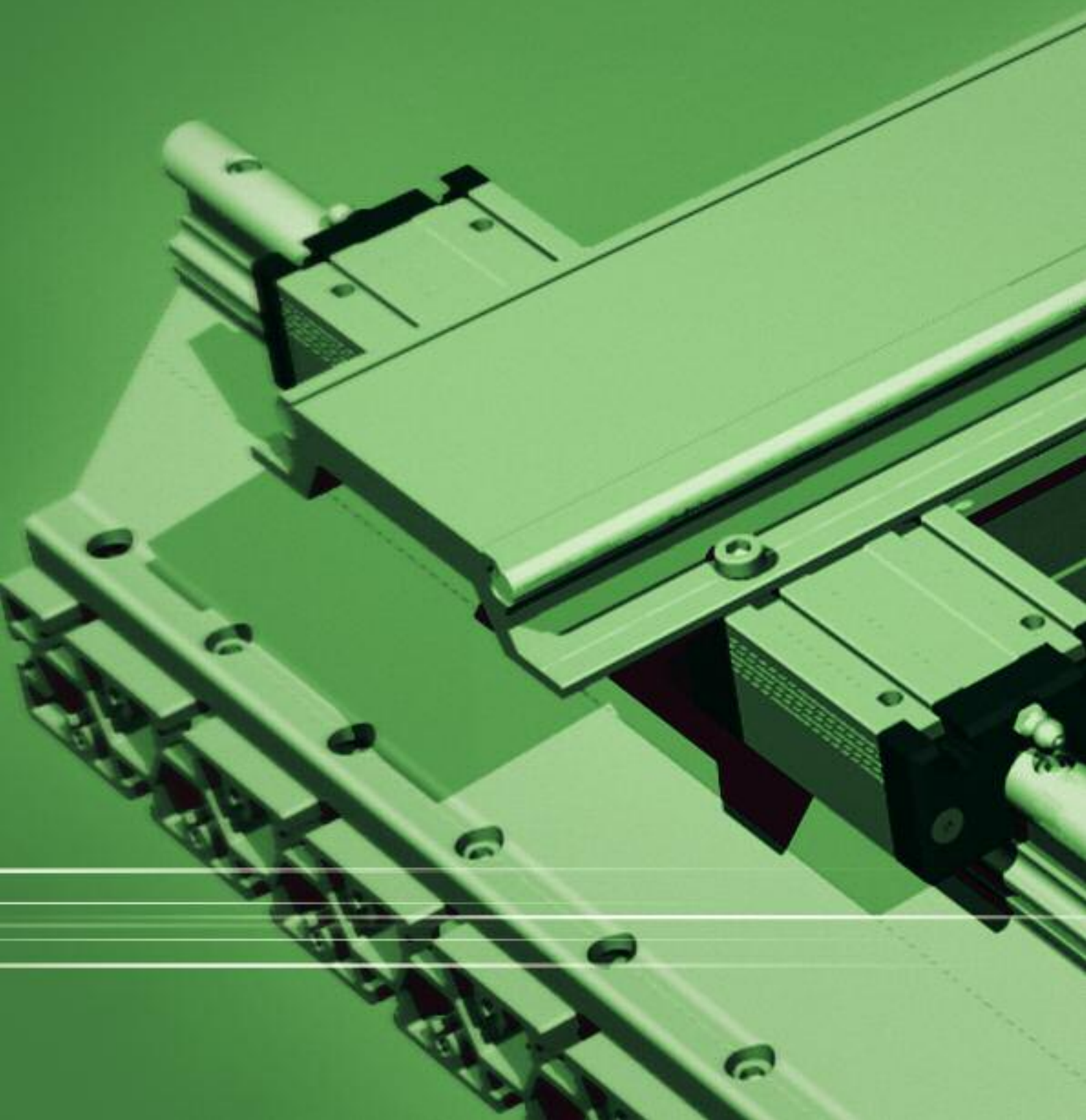



# Mechanics

## MECHANICS

Aluminium profiles .....B-2

Linear guides .....B-4

Drive elements .....B-26

Linear units .....B-34

Rotational units .....B-72

## Tried and tested proprietary developments for a wide range of applications

isel aluminium profiles all come from our own production and are often used in industry and mechanical engineering. With their flexible application options, their compact design and their high stability, any plant can be installed easily and quickly.

Our aluminium profiles are naturally anodised and extrusion press profiles manufactured in accordance with DIN EN 12020-2 in the standard lengths of 1 m / 3 m and 6 m, width and height are variable. On request, however, we can also cut your aluminium profile to the length you wish.

Various aluminium profiles cover a wide range of requirements, so that you too can find the right solution for your design at isel.

Whether it is for the construction of machine frames, connecting elements or universal clamping surfaces:

With our aluminium profiles you just can't go wrong!

Our aluminium profiles offer excellent value for money and combine low weight with high strength. An extensive range of accessories completes our aluminium profile range.

You will find further information in our separate sub-catalogue and, of course, also at [www.isel.com](http://www.isel.com)



[www.isel.com/en/products/mechanics/aluminium-profiles](http://www.isel.com/en/products/mechanics/aluminium-profiles)



Direct link to the e paper catalogue





# Aluminium profiles

## Overview



### Connection and angle profiles

- aluminium T-profiles naturally anodised, length 6 m
- T-slot and hollow indentions for nuts and bolts
- chipless compound of blanks with quick connectors
- fitting plate material like perforated plates mirror glass, acrylic, PVC and web plates



### Frame and rectangular profiles

- aluminium T-profiles naturally anodised, length 6 m
- angle connections with miter for frame and display application
- T-slots suitable for LED strip and plate fastening 1 to 8 mm
- die cast aluminium feet and castors for mobile use and slot covers in different colors



### Hollow and stand profiles

- aluminium T-profiles naturally anodised, length 6 m
- suitable design for stands and trade fair structures with angle connectors
- fastening elements for advertising banners, lighting and boards
- adjustable feet and rollers for different floors, slot nuts and bolts up to M8 threads



### Clamping and mounting profiles

- aluminium T-profiles naturally anodised, length 3 m and 6 m
- single-sided and double-sided T-slots with 25 and 50 mm raster
- clamping plates for machines, tables and linear guides
- slot nuts and threaded inserts for M4 to M8

# Linear guides

# Overview

Slides functional overview  
General notes



B-4

LFS-8-1  
LFS-8-2  
Linear guide rails



B-6

with LW 6 trolley  
with WS 1 aluminium slide

LFS-8-3  
Linear guide rails



B-8

with LW 7 trolley  
with WS 3 aluminium slide

LFS-8-4  
Linear guide rails



B-10

with LW 7 trolley  
with WS 3 aluminium slide

LFS-12-1  
Linear guide rails



B-14

with LW 3 trolley  
with WS 4 aluminium slide  
with LS 1 steel slides

# Linear guides

## Overview

### LFS-12-11

Linear guide rails



B-16

with LW 5 trolley  
with WS 6 aluminium slide

### LFS-12-2

Linear guide rails



B-18

with LW 3 trolley  
with WS 4 aluminium slide

### LFS-12-3

Linear guide rails



B-20

with LW 2 trolley  
with LW 8 trolley  
with WS 7 aluminium slide

### LFS-12-10

Linear guide rails



B-22

with LW 4 trolley  
with WS 8 aluminium slide  
with dual track set 1 + 2

### Accessories

B-24



CAD data can be found on [www.isel.com](http://www.isel.com) and



# Linear guide slide function

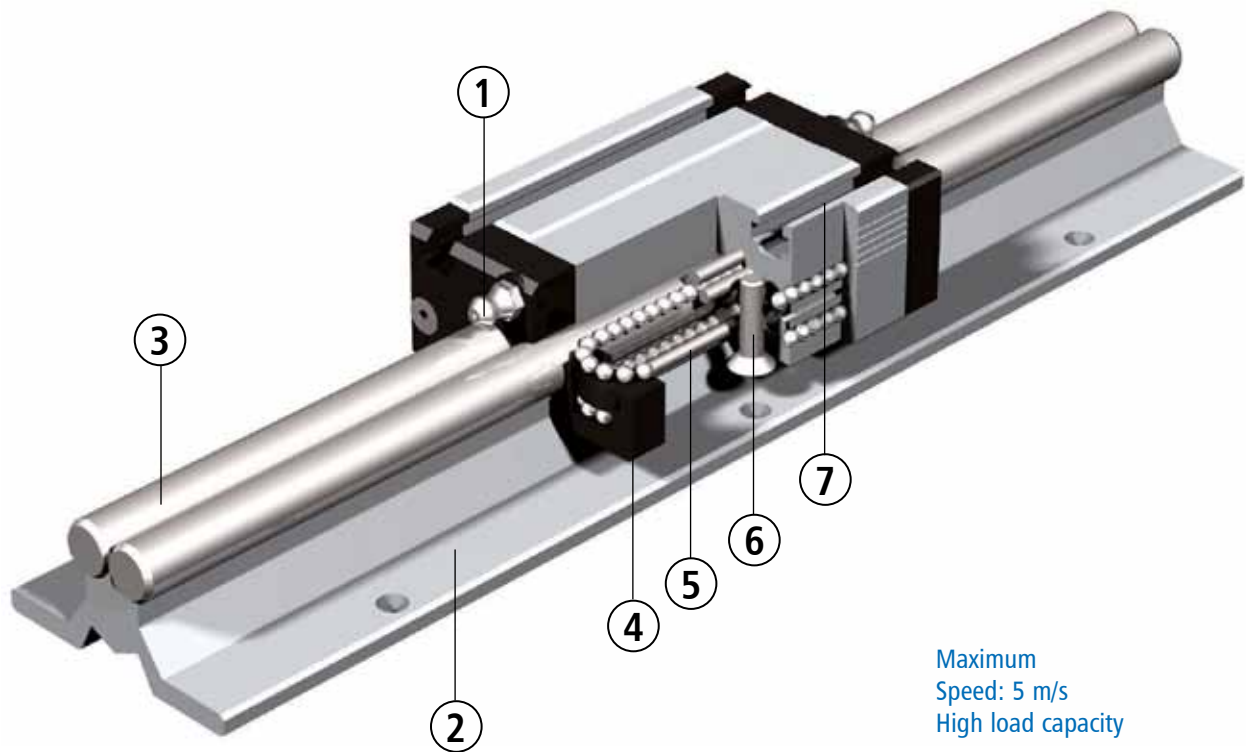

Maximum  
Speed: 5 m/s  
High load capacity

## Aluminium shaft slides

The shaft slides from isel are perfectly suited for assembling of complex multiple axis systems for handling and machining.

The wide range of models covers a multitude of applications.

All models can be produced to order with various profile lengths (70, 100, 150 and 200 mm).

1. Lubrication options to both sides for the recirculating balls.
2. The basic supports for all linear guides are extruded aluminium profiles compliant with DIN EN 12020-2, which are provided with T-slot inserts for fastening in the body of the profile or with drilled hole fixing points.
3. Precision steel shafts with a hardness of  $60 \pm 2$  HRC are used as guide rails. All LFS-8 versions are optionally available with stainless steel shafts.
4. The recirculating ball steering systems are glass fibre reinforced.
5. There are recirculating balls in the linear slide. Ball bearings run in each case between two ground steel pins and the guidance shaft.
6. The slide is adjusted with self-locking setting screws. This is how the rows of balls and shafts or pins are used with each other and thus prestressed. The slide are preset in the factory to the correct stress. All shaft slides are optionally available in a stainless version.
7. To secure transport loads, slot plates, etc., the shaft slide are provided with T-slot inserts or fixing borings.

# General notes

## Load capacity and working life

### Installation site

In principal, the installation site for linear guides can be chosen anywhere. You merely have to consider whether all the forces and moments arising are below the maximum values for the relevant axes.

### Temperatures

All linear guides are designed for continuous operation at ambient temperatures of up to 60 °C. In short-term operation, maximum temperatures of 80 °C are permissible.

Linear guides are unsuitable for temperatures below freezing.

### Straightness/Warping

The aluminium profiles used are extruded profiles, which exhibit divergences regarding straightness and may be warped, owing to the manufacturing process.

The tolerance of this deviation is set out in DIN EN 12020-2.

In the worst case, the linear guide deviations equal these limits, but typically they are lower.

In order to achieve the desired guidance accuracy, the guide must be aligned using shims or clamped to a bearing service machined to the corresponding accuracy. This achieves tolerances of 0.1 mm/1000 mm.

### Principles

#### Load capacity and working life

The dimensioning of a linear guide is based on the load capacity of the individual elements. The load capacity is described by:

- the dynamic load factor C
- the static load factor C0
- the static torques MOX, MOY and MOZ

The basis of the dynamic load factors according to DIN is a nominal working life of 100,000 m displacement path. Far East suppliers often quote load factors for a nominal working life of 50,000 m displacement path; this produces load factor figures which are approximately 20% higher than those according to DIN.

#### Dynamic load capacity

The fatigue characteristics of the material determine the dynamic load capacity. The working life - the fatigue period - also depends on:

- the stress on the linear guide
- the speed at which the linear guide moves
- the statistical randomness of the first damage occurring

### Useful life

Useful life means the working life actually achieved by a linear guide. The useful life may differ from the computed working life.

The following can lead to premature failure through wear or fatigue:

- Misalignments between guide rails or guidance elements
- Contamination of the guide rails
- Insufficient lubrication
- Oscillating motion with very small lifts (formation of grooves)
- Vibrations at rest (formation of grooves)

Owing to the multiplicity of installation and operating relationships, it is impossible to determine the useful life of a linear guide exactly in advance. The safest way to make an accurate estimate of the useful life is, as before, a comparison with similar installations.

# Linear guide rails

## LFS-8-1 LFS-8-2

Figure:  
LFS-8-1 with  
aluminium slide WS 1/70



Figure:  
LFS-8-2 with  
aluminium slide WS 1/70

### Features

- W 30 x H 20 mm (LFS-8-1)  
W 30 x H 32.5 mm (LFS-8-2)
- 2 precision steel shafts Ø 8 mm
- anti-twist lock
- aluminium shaft housing profile, naturally anodised
- fixing from below with M6 tapped rails in the T-key insert
- conditionally self-supporting
- special lengths to order
- weights: approx. 1.6 kg/m (LFS-8-1)  
approx. 2.0 kg/m (LFS-8-2)

### Options:

- stainless steel version
- drilled for M6 (LFS-8-1 only)

### Ordering key

**235 00X XXXX**

LFS-8-1 / standard = <b>0</b>	<b>Length LFS-8-1</b>	<b>Length LFS-8-2</b>
LFS-8-1 / stainless = <b>1</b>	in mm (in a grid of 100 mm)	in mm (in a grid of 100 mm)
LFS-8-2 / standard = <b>2</b>	e.g. <b>0029</b> = Length 298	e.g. <b>0298</b> = Length 298
LFS-8-2 / stainless = <b>3</b>	<b>0299</b> = Length 2998	<b>2998</b> = Length 2998

Steel shaft length: total length L - 3 mm  
Profile up to 6000 mm available without impact connection, steel shafts divided.

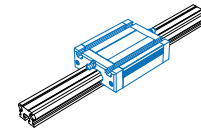

### Aluminium slide

- with recirculating ball guide
- clamping surface plane milled
- M6 T-key inserts
- central lubrication option
- adjustable for no play
- option: stainless steel version

### Load data

Shaft slide WS 1/70	
C <sub>0</sub>	3114 N
C	1846 N
F <sub>1</sub> static	2659 N
F <sub>1</sub> dynamic	1576 N
F <sub>2</sub> static	3114 N
F <sub>2</sub> dynamic	1846 N
M <sub>x</sub> static	37.3 Nm
M <sub>y</sub> static	100.5 Nm
M <sub>z</sub> static	117.6 Nm
M <sub>x</sub> dynamic	22.1 Nm
M <sub>y</sub> dynamic	59.5 Nm
M <sub>z</sub> dynamic	69.7 Nm

Shaft slide WS 1	
C <sub>0</sub>	4590 N
C	2390 N
F <sub>1</sub> static	3920 N
F <sub>1</sub> dynamic	2041 N
F <sub>2</sub> static	4590 N
F <sub>2</sub> dynamic	2390 N
M <sub>x</sub> static	55.0 Nm
M <sub>y</sub> static	148.1 Nm
M <sub>z</sub> static	173.4 Nm
M <sub>x</sub> dynamic	28.6 Nm
M <sub>y</sub> dynamic	77.1 Nm
M <sub>z</sub> dynamic	90.2 Nm

Trolley LW 6	
C <sub>0</sub>	2160 N
C	4000 N
F <sub>1</sub> static	4320 N
F <sub>1</sub> dynamic	3792 N
F <sub>2</sub> static	2160 N
F <sub>2</sub> dynamic	4000 N
M <sub>x</sub> static	121.1 Nm
M <sub>y</sub> static	194.4 Nm
M <sub>z</sub> static	97.2 Nm
M <sub>x</sub> dynamic	106.3 Nm
M <sub>y</sub> dynamic	170.6 Nm
M <sub>z</sub> dynamic	180.0 Nm

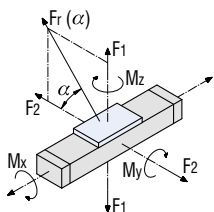

$$Fr(\alpha) = \frac{F_2}{\cos \alpha}$$

$$Fr(\alpha) = \frac{F_1}{\sin \alpha}$$

L 96 × W 72 × H 28.5 mm (WS 1/70)  
(weight: approx. 0.4 kg)

Part no.: **223100 0070**  
Stainless steel: **223101 0070**

L 126 × W 72 × H 28.5 mm (WS 1)  
(weight: approx. 0.5 kg)

Part no.: **223100**  
Stainless steel: **223101**

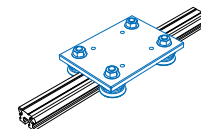

### Trolley LW 6

- L 125 x W 90 x H 7.7 mm
- ground steel plate
- 4 rollers Ø 31 mm, sealed for life
- adjustable for no play
- weight: approx. 1 kg

Part no.: **223011**

# Linear guide rails

## LFS-8-1 LFS-8-2

### Bending

■ Load config. 1

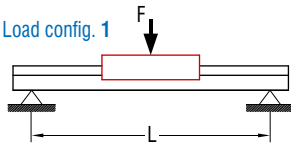

■ Load config. 2

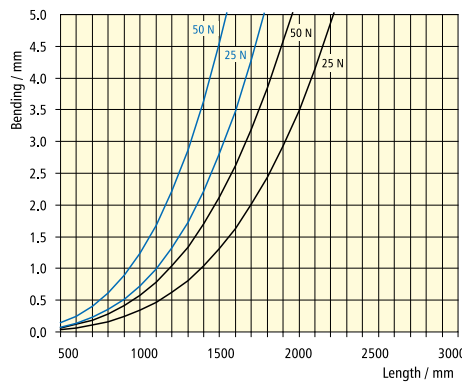
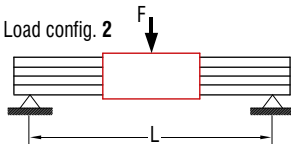

LFS-8-1

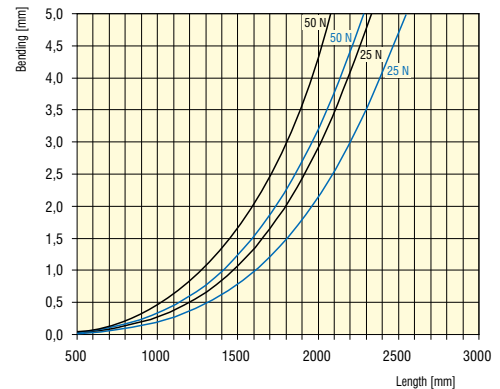

LFS-8-2

### Dimensioned drawings

LFS-8-1 or LFS-8-2 with aluminium slide WS 1/70 or WS 1

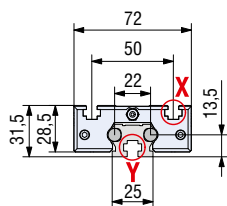

LFS-8-1

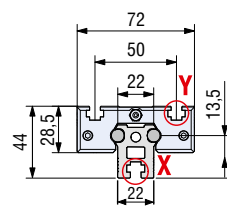

LFS-8-2

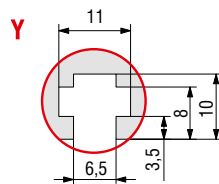
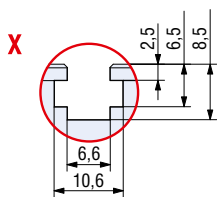
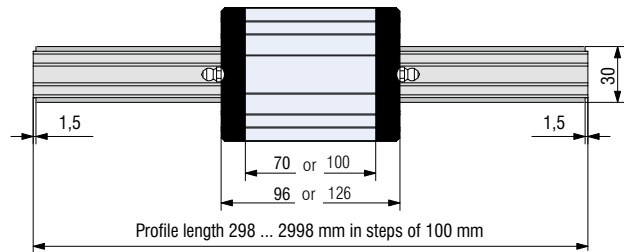

LFS-8-1 or LFS-8-2 with trolley LW6

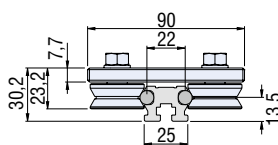

LFS-8-1

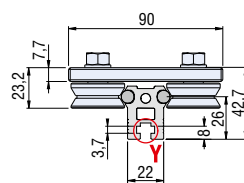

LFS-8-2

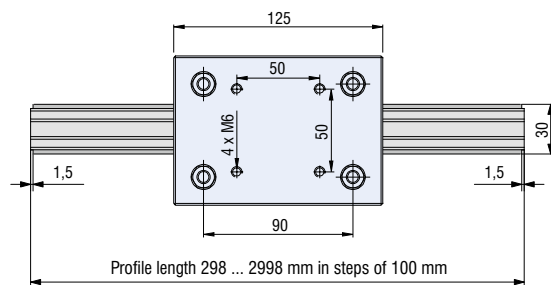

# Linear guide rails

## LFS-8-3



### Features

- W 115 x H 25.5 mm
- 2 precision steel shafts Ø 8 mm
- particularly resistant to twisting
- aluminium shaft housing profile, naturally anodised
- fixing from above through M6 drillings in the raster 100 mm
- conditionally self-supporting
- special lengths to order
- weight: approx. 3.2 kg/m
- option: stainless steel version

### Ordering key

#### 235 00X XXXX

Standard = 4      Length in mm (in 100 mm raster)  
 Stainless = 5      e.g. 0029 = Length 296  
                               0299 = Length 2996

Length overall L - 1 mm

Profile up to 6000 mm available without impact connection, steel shafts divided.

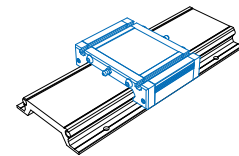

### Aluminium slide

- with recirculating ball guide
- clamping surface plane milled
- M6 T-key inserts
- central lubrication option
- adjustable for no play
- option: stainless steel version

L 96 x W 130 x H 32 mm (WS 3/70)  
 (weight: approx. 0.5 kg)

Part no.: 223103 0070

Stainless steel: 223103 1070

L 176 x W 130 x H 32 mm (WS 3)  
 (weight: approx. 0.9 kg)

Part no.: 223103

Stainless steel: 223103 1000

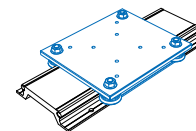

### Trolley LW 7

- L 175 x W 150 x H 7.5 mm
- ground steel plate
- 4 rollers Ø 31 mm, sealed for life
- adjustable for no play
- weight: approx. 2 kg

Part no.: 223012

### Load data

Shaft slide WS 3/70	
C <sub>0</sub>	3141 N
C	1879 N
F <sub>1</sub> static	2682 N
F <sub>1</sub> dynamic	1604 N
F <sub>2</sub> static	3141 N
F <sub>2</sub> dynamic	1879 N
M <sub>x</sub> static	115.7 Nm
M <sub>y</sub> static	105.3 Nm
M <sub>z</sub> static	123.3 Nm
M <sub>x</sub> dynamic	69.2 Nm
M <sub>y</sub> dynamic	62.9 Nm
M <sub>z</sub> dynamic	73.7 Nm

Shaft slide WS 3	
C <sub>0</sub>	6945 N
C	3190 N
F <sub>1</sub> static	5931 N
F <sub>1</sub> dynamic	2724 N
F <sub>2</sub> static	6945 N
F <sub>2</sub> dynamic	3190 N
M <sub>x</sub> static	255.9 Nm
M <sub>y</sub> static	232.8 Nm
M <sub>z</sub> static	272.5 Nm
M <sub>x</sub> dynamic	117.5 Nm
M <sub>y</sub> dynamic	106.9 Nm
M <sub>z</sub> dynamic	125.1 Nm

Trolley LW 7	
C <sub>0</sub>	2160 N
C	4000 N
F <sub>1</sub> static	4320 N
F <sub>1</sub> dynamic	3792 N
F <sub>2</sub> static	2160 N
F <sub>2</sub> dynamic	4000 N
M <sub>x</sub> static	246.8 Nm
M <sub>y</sub> static	302.4 Nm
M <sub>z</sub> static	151.2 Nm
M <sub>x</sub> dynamic	216.7 Nm
M <sub>y</sub> dynamic	265.4 Nm
M <sub>z</sub> dynamic	280 Nm

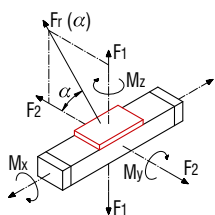

$$Fr(\alpha) = \frac{F_2}{\cos \alpha}$$

$$Fr(\alpha) = \frac{F_1}{\sin \alpha}$$



# Linear guide rails

# LFS-8-3

## Bending

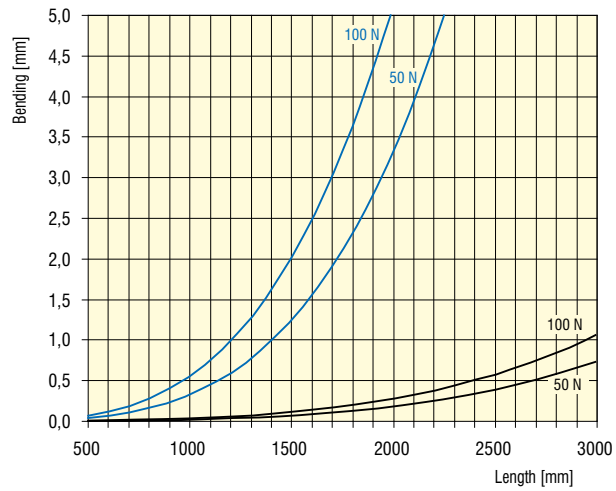
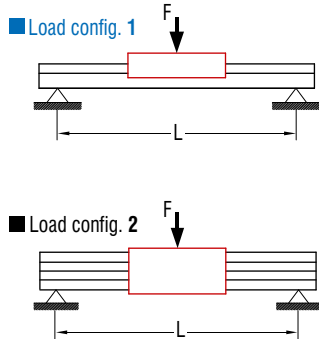

## Dimensioned drawings

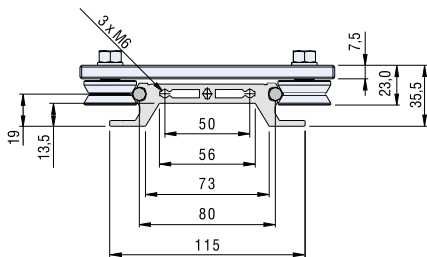
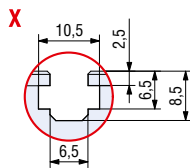
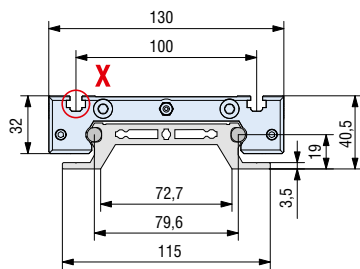

LFS-8-3 with aluminium slide WS 3/70 or WS 3

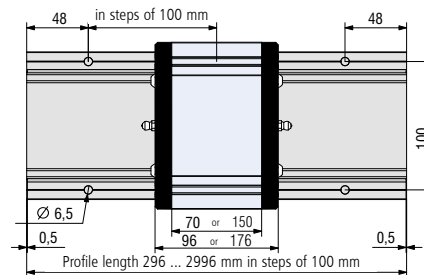

LFS-8-3 with trolley LW7

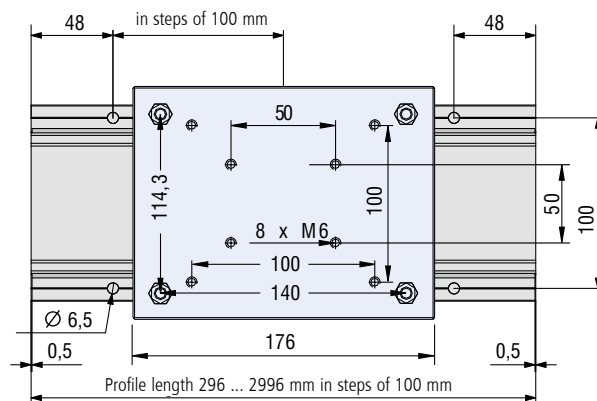

# Linear guide rails

## LFS-8-4



Figure:  
LFS-8-4 with 2 steel shafts  
and an aluminium slot

Figure:  
LFS-8-4 with 4 steel shafts  
and two aluminium slide (optional)

### Features

- W 80 x H 80 mm
- 4 precision steel shafts Ø 8 mm
- anti-twist
- aluminium shaft housing profiles, naturally anodised
- fixing from below with M6 tapped rails in the T-slot inserts or in the head side through M8 drillings
- side T-key inserts for limit switch securing
- conditionally self-supporting
- special lengths to order
- weight: approx. 7.2 kg/m
- options: stainless steel version with 2 steel shafts 2 slide or trolley

### Ordering key

#### 235 00X XXXX

Standard = 6      Length in mm (in 100 mm raster)  
 Stainless = 7      e.g. 0029 = Length 298  
                              0299 = Length 2998

Steel shaft length: total length L - 3 mm

Profile up to 6000 mm available without impact connection, steel shafts divided.

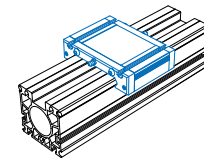

### Aluminium slide

- clamping surface plane milled
- M6 T-slot inserts
- central lubrication option
- adjustable for no play
- option: stainless steel version

L 96 x W 130 x H 32 mm (WS 3/70)  
 (weight: approx. 0.5 kg)

Part no.: **223103 0070**

Stainless steel: **223103 1070**

L 176 x W 130 x H 32 mm (WS 3)  
 (weight: approx. 0.9 kg)

Part no.: **223103**

Stainless steel: **223103 1000**

### Load data

Shaft slide WS 3/70	
C <sub>0</sub>	3141 N
C	1879 N
F <sub>1</sub> static	2682 N
F <sub>1</sub> dynamic	1604 N
F <sub>2</sub> static	3141 N
F <sub>2</sub> dynamic	1879 N
M <sub>x</sub> static	115.7 Nm
M <sub>y</sub> static	105.3 Nm
M <sub>z</sub> static	123.3 Nm
M <sub>x</sub> dynamic	69.2 Nm
M <sub>y</sub> dynamic	62.9 Nm
M <sub>z</sub> dynamic	73.7 Nm

Shaft slide WS 3	
C <sub>0</sub>	6945 N
C	3190 N
F <sub>1</sub> static	5931 N
F <sub>1</sub> dynamic	2724 N
F <sub>2</sub> static	6945 N
F <sub>2</sub> dynamic	3190 N
M <sub>x</sub> static	255.9 Nm
M <sub>y</sub> static	232.8 Nm
M <sub>z</sub> static	272.5 Nm
M <sub>x</sub> dynamic	117.5 Nm
M <sub>y</sub> dynamic	106.9 Nm
M <sub>z</sub> dynamic	125.1 Nm

Trolley LW 7	
C <sub>0</sub>	2160 N
C	4000 N
F <sub>1</sub> static	4320 N
F <sub>1</sub> dynamic	3792 N
F <sub>2</sub> static	2160 N
F <sub>2</sub> dynamic	4000 N
M <sub>x</sub> static	246.8 Nm
M <sub>y</sub> static	302.4 Nm
M <sub>z</sub> static	151.2 Nm
M <sub>x</sub> dynamic	216.7 Nm
M <sub>y</sub> dynamic	265.4 Nm
M <sub>z</sub> dynamic	280 Nm

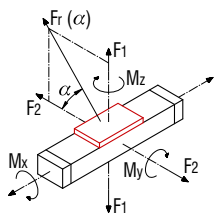

$$Fr(\alpha) = \frac{F_2}{\cos \alpha}$$

$$Fr(\alpha) = \frac{F_1}{\sin \alpha}$$

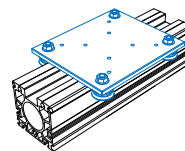

### Trolley LW 7

- L 175 x W 150 x H 7.5 mm
- ground steel plate
- 4 rollers Ø 31 mm, sealed for life
- adjustable for no play
- weight: approx. 2 kg

Part no.: **223012**

# Linear guide rails

# LFS-8-4

## Bending

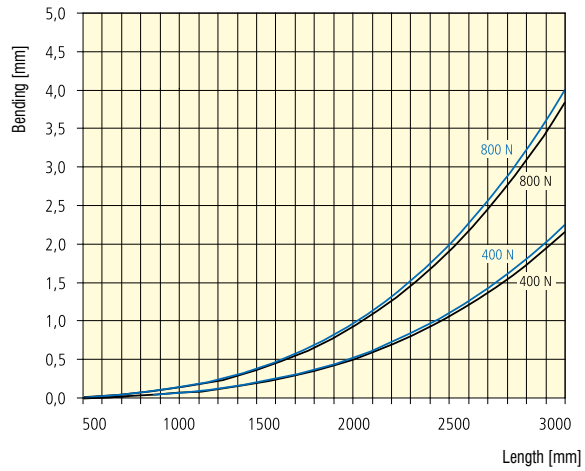
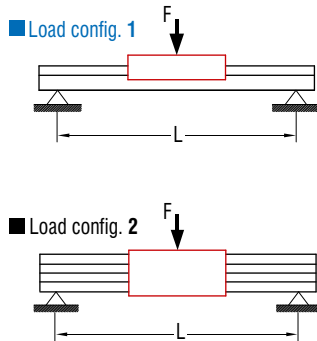

## Dimensioned drawings

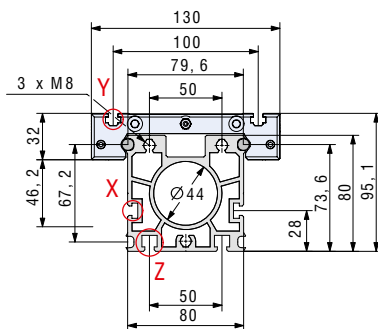

LFS-8-3 with aluminium slide WS 3/70 or WS 3

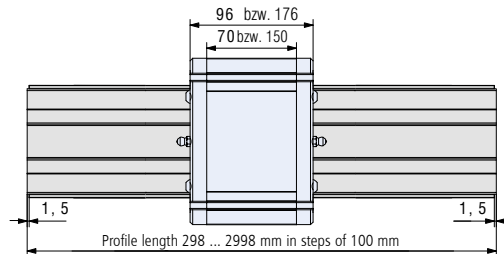

LFS-8-4 with trolley LW 7

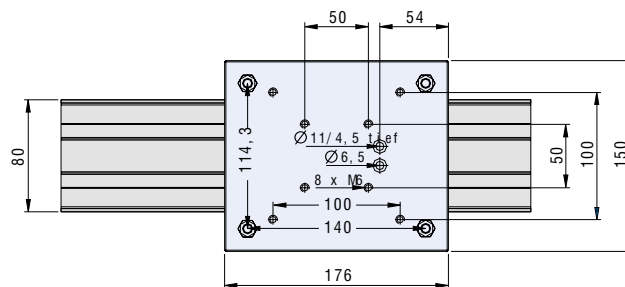
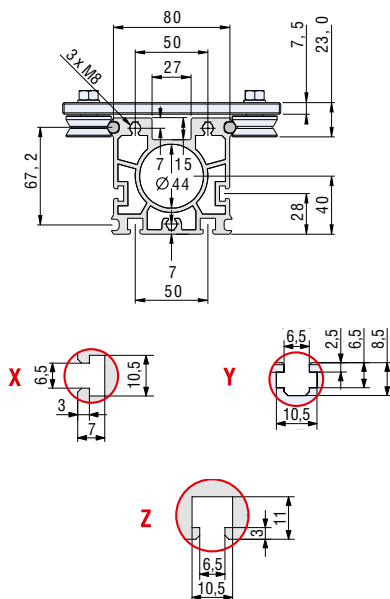

# Linear guide rails

# LFS-12-1

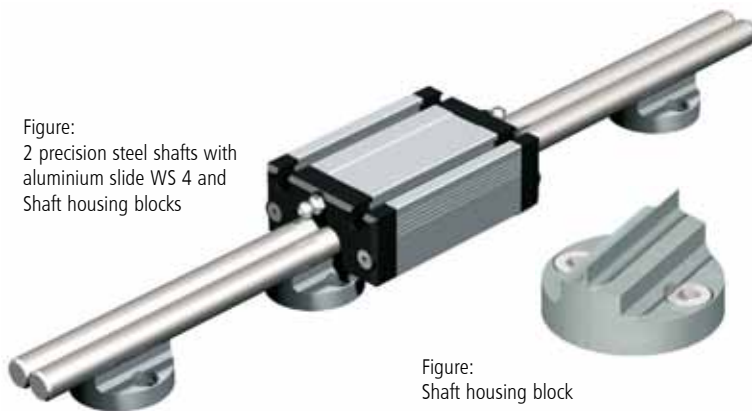

Figure:  
2 precision steel shafts with  
aluminium slide WS 4 and  
Shaft housing blocks

Figure:  
Shaft housing block

## Features

- W 40 x H 27 mm
- 2 precision steel shafts Ø 12 mm
- anti-twist
- aluminium shaft housing blocks
- securing from above or below with M6 drillings in the housing blocks
- guide any length up to 3m
- special lengths to order
- weight: approx. 1.9 kg/m

## Ordering key

**227 312 XXXX**

Length in mm (in 100 mm raster)  
e.g. **0298** = Length 298  
**2998** = Length 2998  
Special lengths to order

**N.B.!**  
The part no. refers to one steel shaft only !

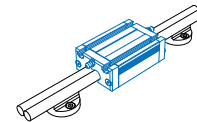

### Aluminium slide

- clamping surface plane milled
- adjustable for no play
- option: stainless steel version

L 94 x W 62 x H 31.5 mm (WS 4/70)  
(weight: approx. 0.33 kg)

Part no.: **223104 0070**  
Stainless steel: **223104 1070**

L 124 x W 62 x H 31.5 mm (WS 4)  
(weight: approx. 0.46 kg)

Part no.: **223104**  
Stainless steel: **223104 1000**

## Load data

Shaft slide WS 4/70		Shaft slide WS 4		Steel slide LS 1		Trolley LW 8	
C <sub>0</sub>	3003 N	C <sub>0</sub>	4868 N	C <sub>0</sub>	3508 N	C <sub>0</sub>	2160 N
C	1873 N	C	2426 N	C	2105 N	C	4000 N
F <sub>1</sub> static	2821 N	F <sub>1</sub> static	4157 N	F <sub>1</sub> static	3549 N	F <sub>1</sub> static	4320 N
F <sub>1</sub> dynamic	1599 N	F <sub>1</sub> dynamic	2071 N	F <sub>1</sub> dynamic	2130 N	F <sub>1</sub> dynamic	3846 N
F <sub>2</sub> static	3303 N	F <sub>2</sub> static	4868 N	F <sub>2</sub> static	3508 N	F <sub>2</sub> static	2160 N
F <sub>2</sub> dynamic	1873 N	F <sub>2</sub> dynamic	2426 N	F <sub>2</sub> dynamic	2105 N	F <sub>2</sub> dynamic	4000 N
M <sub>x</sub> static	29.8 Nm	M <sub>x</sub> static	43.9 Nm	M <sub>x</sub> static	36.2 Nm	M <sub>x</sub> static	109.5 Nm
M <sub>y</sub> static	105.3 Nm	M <sub>y</sub> static	155.2 Nm	M <sub>y</sub> static	129.0 Nm	M <sub>y</sub> static	194.4 Nm
M <sub>z</sub> static	123.3 Nm	M <sub>z</sub> static	181.7 Nm	M <sub>z</sub> static	127.5 Nm	M <sub>z</sub> static	97.2 Nm
M <sub>x</sub> dynamic	16.8 Nm	M <sub>x</sub> dynamic	21.8 Nm	M <sub>x</sub> dynamic	21.7 Nm	M <sub>x</sub> dynamic	97.4 Nm
M <sub>y</sub> dynamic	59.7 Nm	M <sub>y</sub> dynamic	77.3 Nm	M <sub>y</sub> dynamic	77.4 Nm	M <sub>y</sub> dynamic	173.0 Nm
M <sub>z</sub> dynamic	69.9 Nm	M <sub>z</sub> dynamic	90.5 Nm	M <sub>z</sub> dynamic	76.5 Nm	M <sub>z</sub> dynamic	180.0 Nm

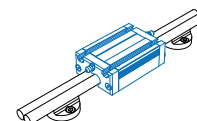
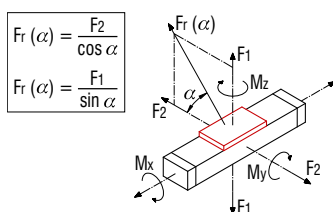

### Steel slide LS 1

- clamping surface ground
  - weight: approx. 0.8 kg
- Part no.: **223006**

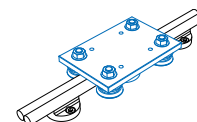

### Trolley LW 3

- L 125 x W 85 x H 7.7 mm
  - ground steel plate
  - weight: approx. 0.9 kg
- Part no.: **223008**

### Shaft housing blocks

- Ø 40 mm, hole spacing 28 mm
  - cast zinc, VE 10 units
- Part no.: **221501**

# Linear guide rails

# LFS-12-1

## Dimensioned drawings

LFS-12-1 with trolley LW 3

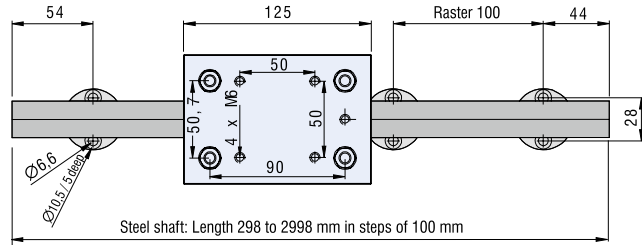
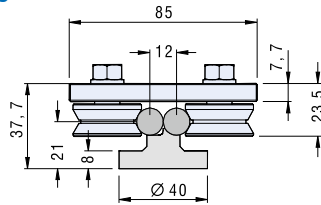

LFS-12-1 with Shaft slide WS 4/70 or WS 4

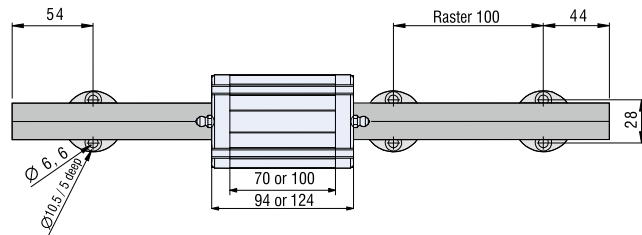
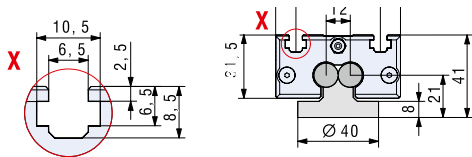

LFS-12-1 with steel slide LS 1

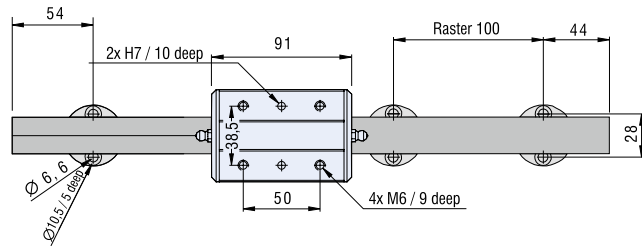
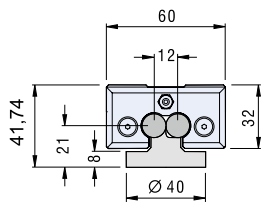

Shaft housing block

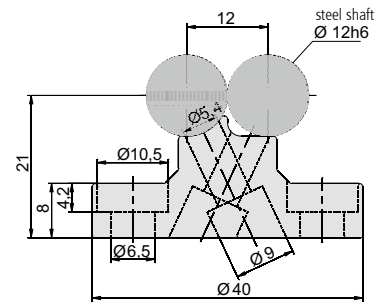
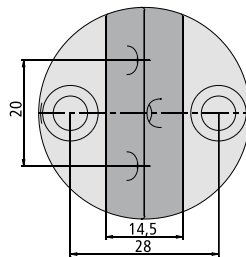

# Linear guide rail

## LFS-12-11



### Features

- W 20 x H 31 mm
- precision steel shaft Ø 12 mm
- aluminium shaft housing profile, naturally anodised
- securing from below with M6 tapped rail in T-slot insert on flat surface
- special lengths available on request
- weight: approx. 1.3 kg/m

### Ordering key

**220 002 XXXX**

Length in mm

e.g. **0298** = Length 298

**0998** = Length 998

Profile length = Length overall L -2 mm

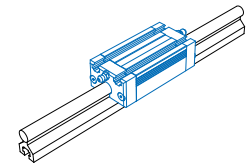

### Aluminium slides

- with recirculating ball guide
- M6 T-slot inserts
- central lubrication system option
- adjustable for no play
- option: stainless steel version

### Load data

Shaft slides WS 6/70	
C <sub>0</sub>	3303 N
C	1873 N
F <sub>1</sub> static	2821 N
F <sub>1</sub> dynamic	1599 N
F <sub>2</sub> static	3303 N
F <sub>2</sub> dynamic	1873 N
M <sub>x</sub> static	-
M <sub>y</sub> static	105.3 Nm
M <sub>z</sub> static	123.3 Nm
M <sub>x</sub> dynamic	-
M <sub>y</sub> dynamic	59.7 Nm
M <sub>z</sub> dynamic	69.9 Nm

Shaft slides WS 6	
C <sub>0</sub>	4868 N
C	2426 N
F <sub>1</sub> static	4157 N
F <sub>1</sub> dynamic	2071 N
F <sub>2</sub> static	4868 N
F <sub>2</sub> dynamic	2426 N
M <sub>x</sub> static	-
M <sub>y</sub> static	155.2 Nm
M <sub>z</sub> static	181.7 Nm
M <sub>x</sub> dynamic	-
M <sub>y</sub> dynamic	77.3 Nm
M <sub>z</sub> dynamic	90.5 Nm

Trolley LW 5	
C <sub>0</sub>	2160 N
C	4000 N
F <sub>1</sub> static	4320 N
F <sub>1</sub> dynamic	3846 N
F <sub>2</sub> static	2160 N
F <sub>2</sub> dynamic	4000 N
M <sub>x</sub> static	-
M <sub>y</sub> static	162.0 Nm
M <sub>z</sub> static	81.0 Nm
M <sub>x</sub> dynamic	-
M <sub>y</sub> dynamic	144.2 Nm
M <sub>z</sub> dynamic	150.0 Nm

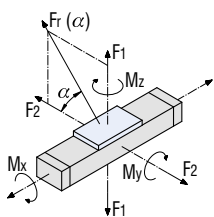

$$Fr(\alpha) = \frac{F_2}{\cos \alpha}$$

$$Fr(\alpha) = \frac{F_1}{\sin \alpha}$$

L 96 x W 50 x H 31.5 mm (WS 6/70)  
(weight: approx. 0.3 kg)

Part no.: **223106 0070**

Stainless steel: **223106 1070**

L 126 x W 50 x H 31,5 mm (WS 6)  
(weight: approx. 0.5 kg)

Part no.: **223106**

Stainless steel: **223106 1000**

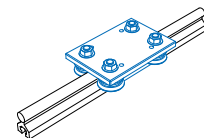

### Trolley LW 5

- L 110 x W 75 x H 7.7 mm
- Ground steel plate
- 4 rollers Ø 31 mm, sealed for life
- Adjustable for no play
- Weight: 0.81 kg

Part no.: **223010**

# Linear guide rail

# LFS-12-11

## Bending

■ Load config. 1

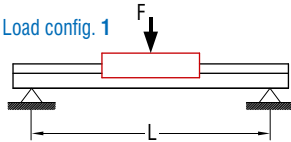

■ Load config. 2

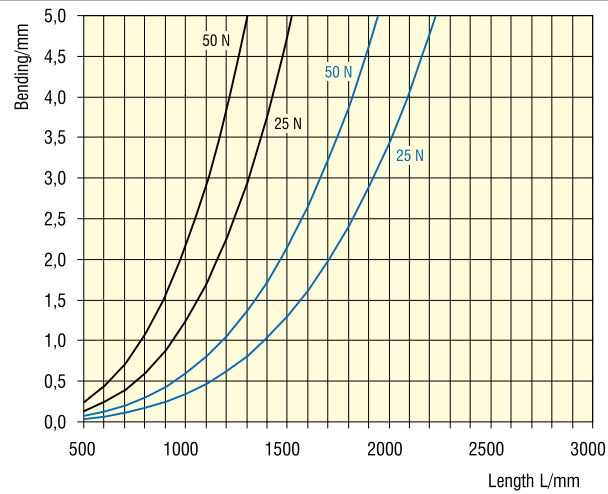
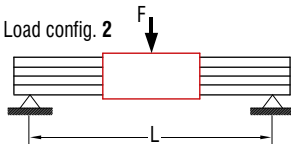

## Dimensioned drawings

LFS-12-11 with aluminium slides WS 6/70 or WS 6

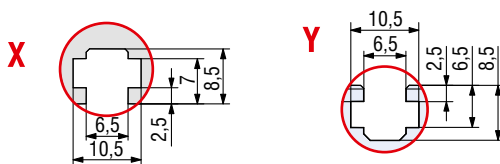
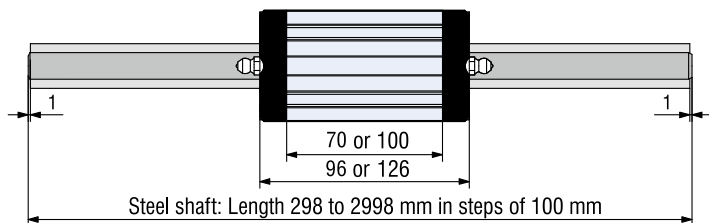
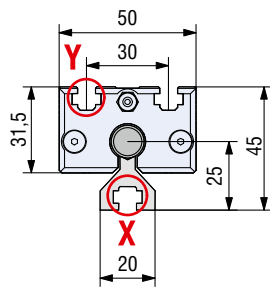

LFS-12-11 with trolley LW 5

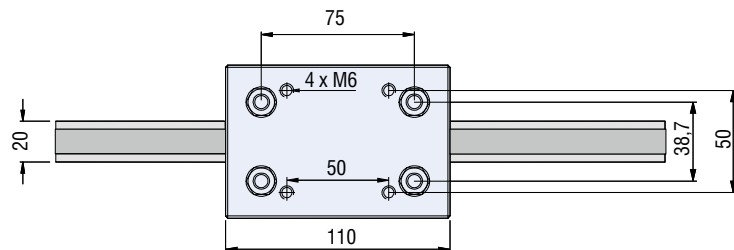
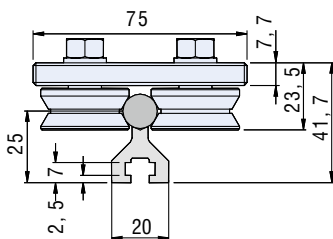

# Linear guide rail

# LFS-12-2



## Features

- W 62 x H 31 mm
- 2 precision steel shafts Ø 12 mm
- anti-twist lock
- aluminium shaft housing profile, naturally anodised
- high parallelism through patented shaft housing outline
- high guidance accuracy
- securing from above or below using drilled holes Ø 6.5 in 100 mm raster on flat surface
- lengths in 100 mm raster
- max. length up to 2998 mm
- special lengths to order
- weight: approx. 3.3 kg/m

## Ordering key

**235 200 XXXX**

Length in mm

e.g. **0298** = Length 298

**0998** = Length 998

Profile length = Length overall L - 2 mm

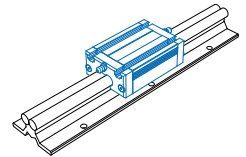

## Aluminium slides

- with recirculating ball guide
- clamping surface plane milled
- adjustable for no play
- option: stainless steel version

L 94 x W 62 x H 31.5 mm (WS 4/70)

(weight: approx. 0.33 kg)

Part no.: **223104 0070**

Stainless steel: **223104 1070**

L 124 x W 62 x H 31.5 mm (WS 4)

(weight: approx. 0.46 kg)

Part no.: **223104**

Stainless steel: **223104 1000**

## Load data

Shaft slides WS 4/70	
C <sub>0</sub>	3003 N
C	1873 N
F <sub>1</sub> static	2821 N
F <sub>1</sub> dynamic	1599 N
F <sub>2</sub> static	3303 N
F <sub>2</sub> dynamic	1873 N
M <sub>x</sub> static	29.8 Nm
M <sub>y</sub> static	105.3 Nm
M <sub>z</sub> static	123.3 Nm
M <sub>x</sub> dynamic	16.8 Nm
M <sub>y</sub> dynamic	59.7 Nm
M <sub>z</sub> dynamic	69.9 Nm

Shaft slides WS 4	
C <sub>0</sub>	4868 N
C	2426 N
F <sub>1</sub> static	4157 N
F <sub>1</sub> dynamic	2071 N
F <sub>2</sub> static	4868 N
F <sub>2</sub> dynamic	2426 N
M <sub>x</sub> static	43.9 Nm
M <sub>y</sub> static	155.2 Nm
M <sub>z</sub> static	181.7 Nm
M <sub>x</sub> dynamic	21.8 Nm
M <sub>y</sub> dynamic	77.3 Nm
M <sub>z</sub> dynamic	90.5 Nm

Trolley LW 3	
C <sub>0</sub>	2160 N
C	4000 N
F <sub>1</sub> static	4320 N
F <sub>1</sub> dynamic	3846 N
F <sub>2</sub> static	2160 N
F <sub>2</sub> dynamic	4000 N
M <sub>x</sub> static	109.5 Nm
M <sub>y</sub> static	194.4 Nm
M <sub>z</sub> static	97.2 Nm
M <sub>x</sub> dynamic	97.4 Nm
M <sub>y</sub> dynamic	173.0 Nm
M <sub>z</sub> dynamic	180.0 Nm

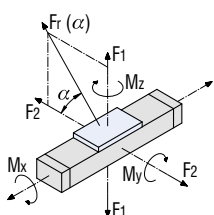

$$Fr(\alpha) = \frac{F_2}{\cos \alpha}$$

$$Fr(\alpha) = \frac{F_1}{\sin \alpha}$$

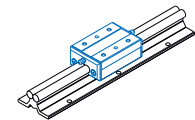

## Steel slide LS 1

- L 91 x W 60 x H 32 mm
- clamping surface ground
- weight: approx. 0.8 kg

Part no.: **223006**

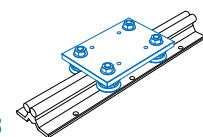

## Trolley LW 3

- L 125 x W 85 x H 7.7 mm
- Ground steel plate
- Weight: 0.93 kg

Part no.: **223008**



# Linear guide rail

# LFS-12-2

## Bending

■ Load config. 1

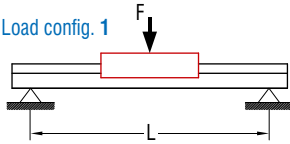

■ Load config. 2

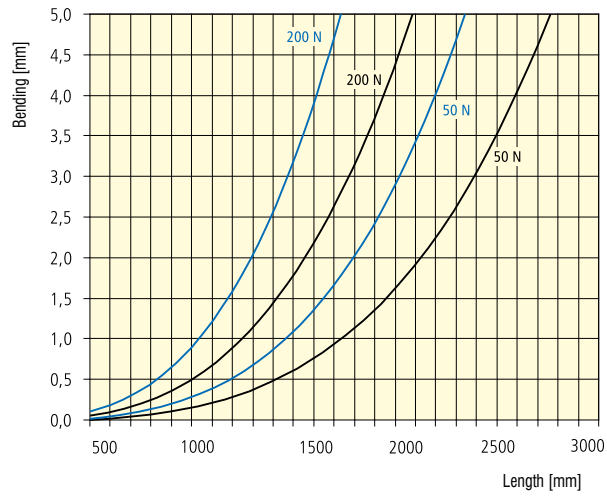
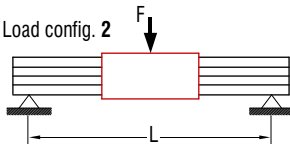

## Dimensioned drawings

LFS-12-2 with aluminium slides **WS 4/70** or **WS 4**

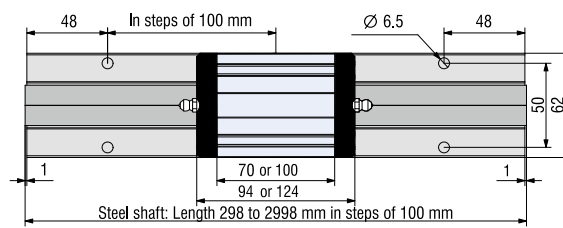
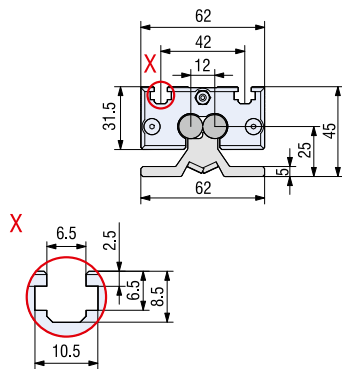

LFS-12-2 with trolley **LW3**

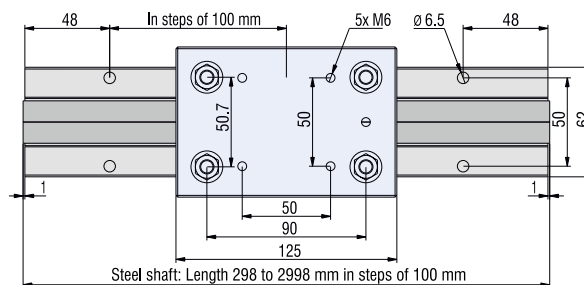
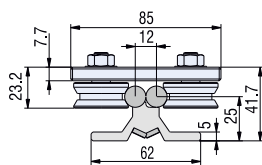

LFS-12-2 with steel slide **LS 1**

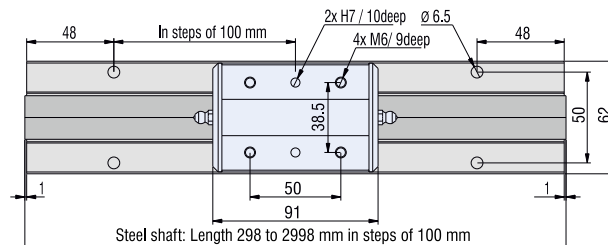
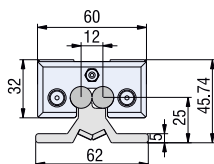

# Linear guide rail

# LFS-12-3



## Features

- W 90 x H 31 mm
- 2 precision steel shafts Ø 12 mm
- anti-twist
- aluminium shaft housing profile, naturally anodised
- increased shaft spacing allows higher torques to be absorbed
- securing from above or below with M6 drillings in 100 mm raster
- any guide length
- weight: approx. 3.9 kg/m

## Ordering key

**235 300 XXXX**

Length in mm (in 100 mm raster)

e.g. **0029** = Length 298

**0299** = Length 2998

Profile length = Length overall L - 2 mm

Special lengths over 3000 mm with rod linkage to order.

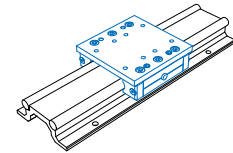

## Slides

- ground steel plate
- central lubrication system option
- adjustable for no play

L 100 x W 100 x H 32 mm (WS 7/70)  
(weight: approx. 0.8 kg)

Part no.: **223107 0070**

L 200 x W 100 x H 32 mm (WS 7)  
(weight: approx. 1.7 kg)

Part no.: **223107**

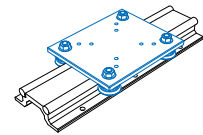

## Trolley LW 8

- L 150 x W 125 x H 7.5 mm
- ground steel plate
- 4 rollers Ø 31 mm, sealed for life
- adjustable for no play
- weight: 1.51 kg

Part no.: **223013**

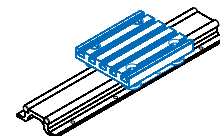

## Trolley LW 2

- L 150 x W 125 x H 34.5 mm
- aluminium T-slot plate
- 4 rollers Ø 31 mm, sealed for life
- adjustable for no play
- weight: 0.97 kg

Part no.: **223005**

## Load data

Shaft slides WS 7/70		Shaft slides WS 7		Trolley LW 2		Trolley LW 8	
C <sub>0</sub>	3303 N	C <sub>0</sub>	7303 N	C <sub>0</sub>	3114 N	C <sub>0</sub>	2160 N
C	1873 N	C	3179 N	C	1846 N	C	4000 N
F <sub>1</sub> static	2821 N	F <sub>1</sub> static	6237 N	F <sub>1</sub> static	2659 N	F <sub>1</sub> static	4320 N
F <sub>1</sub> dynamic	1599 N	F <sub>1</sub> dynamic	2715 N	F <sub>1</sub> dynamic	1576 N	F <sub>1</sub> dynamic	3846 N
F <sub>2</sub> static	3303 N	F <sub>2</sub> static	7303 N	F <sub>2</sub> static	3114 N	F <sub>2</sub> static	2160 N
F <sub>2</sub> dynamic	1873 N	F <sub>2</sub> dynamic	3179 N	F <sub>2</sub> dynamic	1846 N	F <sub>2</sub> dynamic	4000 N
M <sub>x</sub> static	82.0 Nm	M <sub>x</sub> static	181.2 Nm	M <sub>x</sub> static	216.0 Nm	M <sub>x</sub> static	189.2 Nm
M <sub>y</sub> static	105.3 Nm	M <sub>y</sub> static	232.8 Nm	M <sub>y</sub> static	100.5 Nm	M <sub>y</sub> static	248.4 Nm
M <sub>z</sub> static	123.3 Nm	M <sub>z</sub> static	272.5 Nm	M <sub>z</sub> static	108.0 Nm	M <sub>z</sub> static	124.2 Nm
M <sub>x</sub> dynamic	46.4 Nm	M <sub>x</sub> dynamic	78.8 Nm	M <sub>x</sub> dynamic	168.4 Nm	M <sub>x</sub> dynamic	168.4 Nm
M <sub>y</sub> dynamic	59.7 Nm	M <sub>y</sub> dynamic	101.3 Nm	M <sub>y</sub> dynamic	192.3 Nm	M <sub>y</sub> dynamic	221.1 Nm
M <sub>z</sub> dynamic	69.9 Nm	M <sub>z</sub> dynamic	118.6 Nm	M <sub>z</sub> dynamic	200.0 Nm	M <sub>z</sub> dynamic	230.0 Nm

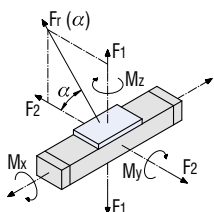

$$Fr(\alpha) = \frac{F_2}{\cos \alpha}$$

$$Fr(\alpha) = \frac{F_1}{\sin \alpha}$$

# Linear guide rail

# LFS-12-3

## Bending

■ Load config. 1

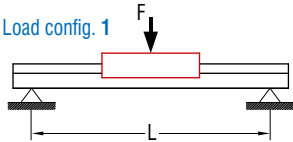

■ Load config. 2

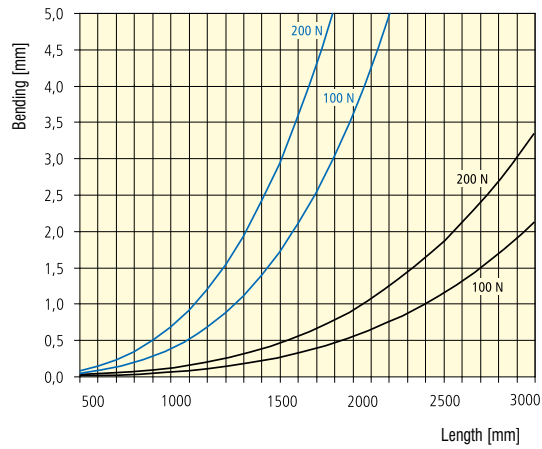
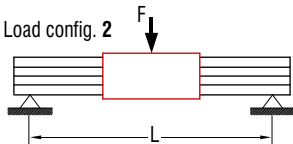

## Dimensioned drawings

LFS-12-3 with aluminium slides WS 7

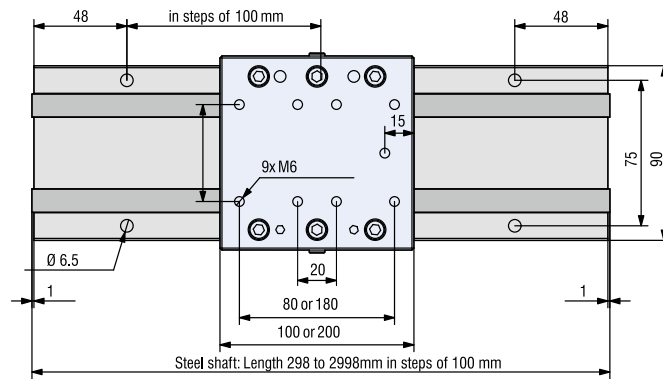
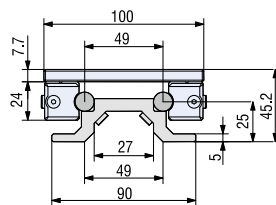

LFS-12-3 with trolley LW 8

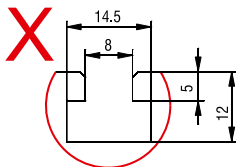
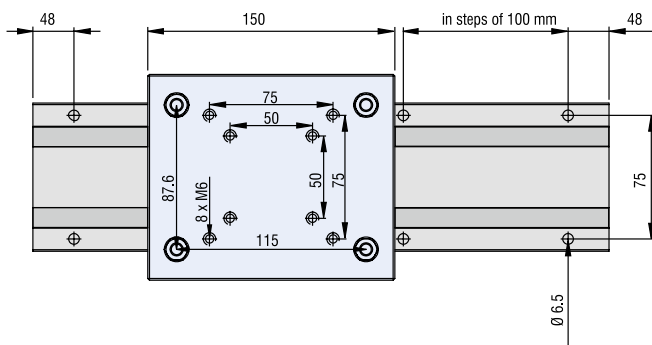
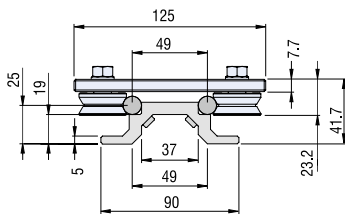

LFS-12-3 with trolley LW 2

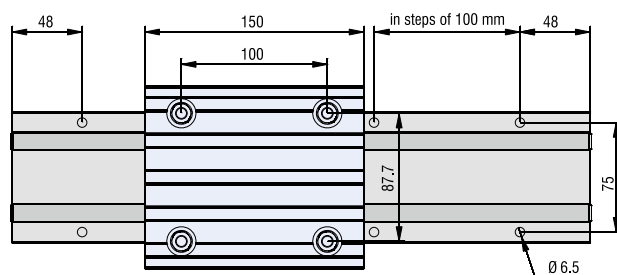
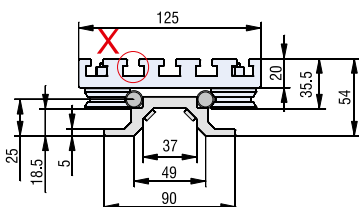

# Linear guide rail

# LFS-12-10



## Features

- W 36 x H 24.5 mm
- 2 precision steel shafts Ø 12 mm
- anti-twist
- aluminium shaft housing profile, naturally anodised
- fixing from below with M6 tapped rail in T-slot insert and from above M6 drillings in the Raster 50 mm
- conditionally self-supporting
- special lengths to order
- weight: approx. 2.9 kg/m

## Ordering key

**220 001 XXXX**

Length in mm (in 100 mm raster)  
e.g. **0300** = Length 296  
**3000** = Length 2996

Profile length = Length overall L - 1 mm

Special lengths over 3000 mm with rod linkage to order.

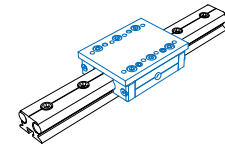

## Slides

- ground steel plate
- lubrication system option
- adjustable for no play

L 100 x W 75 x H 31.5 mm (WS 8/70)  
(weight: approx. 0.7 kg)  
Part no.: **223108 0070**

L 150 x W 75 x H 31.5 mm (WS 8)  
(weight: approx. 1,0 kg)  
Part no.: **223108**

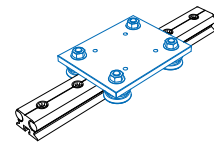

## Trolley LW 4

- L 125 x W 97 x H 7.7 mm
- ground steel plate
- 4 rollers Ø 31 mm, sealed for life
- adjustable for no play
- weight: 1.02 kg

Part no.: **223009**

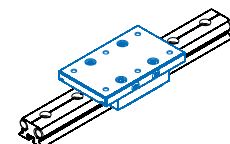

For steel shafts Ø 12 mm

## Dual track set 1

- L75 x W75 x H30.2 mm
- With 2 SMALL linear ball bearings

Part no.: **223001**

## Dual track set 2

- L125 x W75 x H30.2 mm
- With 2 LARGE linear ball bearings

Part no.: **223002**

## Load data

Slides WS 8/70		Slides WS 8		Trolley LW 4		Dual track set 1		Dual track set 2	
C <sub>0</sub>	3303 N	C <sub>0</sub>	4868 N	C <sub>0</sub>	2160 N	C <sub>0</sub>	645 N		1905 N
C	1873 N	C	2426 N	C	4000 N	C	600 N		1125 N
F <sub>1</sub> static	2821 N	F <sub>1</sub> static	4157 N	F <sub>1</sub> static	4320 N	F <sub>1</sub> static	652 N		1927 N
F <sub>1</sub> dynamic	1599 N	F <sub>1</sub> dynamic	2071 N	F <sub>1</sub> dynamic	3846 N	F <sub>1</sub> dynamic	607 N		1138 N
F <sub>2</sub> static	3303 N	F <sub>2</sub> static	4868 N	F <sub>2</sub> static	2160 N	F <sub>2</sub> static	645 N		1905 N
F <sub>2</sub> dynamic	1873 N	F <sub>2</sub> dynamic	2426 N	F <sub>2</sub> dynamic	4000 N	F <sub>2</sub> dynamic	600 N		1125 N
M <sub>x</sub> static	46.7 Nm	M <sub>x</sub> static	68.8 Nm	M <sub>x</sub> static	135.4 Nm	M <sub>x</sub> static	16.0 Nm		46.0 Nm
M <sub>y</sub> static	105.3 Nm	M <sub>y</sub> static	155.2 Nm	M <sub>y</sub> static	194.4 Nm	M <sub>y</sub> static	13.0 Nm		119 Nm
M <sub>z</sub> static	123.3 Nm	M <sub>z</sub> static	181.7 Nm	M <sub>z</sub> static	97.2 Nm	M <sub>z</sub> static	13.0 Nm		118 Nm
M <sub>x</sub> dynamic	26.4 Nm	M <sub>x</sub> dynamic	34.2 Nm	M <sub>x</sub> dynamic	120.5 Nm	M <sub>x</sub> dynamic	15.0 Nm		27.0 Nm
M <sub>y</sub> dynamic	59.7 Nm	M <sub>y</sub> dynamic	77.3 Nm	M <sub>y</sub> dynamic	173.0 Nm	M <sub>y</sub> dynamic	12.0 Nm		71.0 Nm
M <sub>z</sub> dynamic	69.9 Nm	M <sub>z</sub> dynamic	90.5 Nm	M <sub>z</sub> dynamic	180.0 Nm	M <sub>z</sub> dynamic	12.0 Nm		70.0 Nm

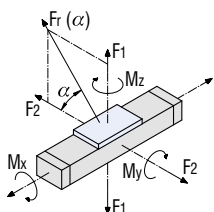

$$Fr(\alpha) = \frac{F_2}{\cos \alpha}$$

$$Fr(\alpha) = \frac{F_1}{\sin \alpha}$$

# Linear guide rail

# LFS-12-10

## Bending

■ Load config. 1

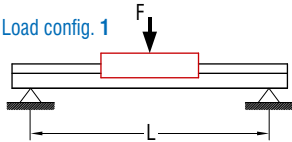

■ Load config. 2

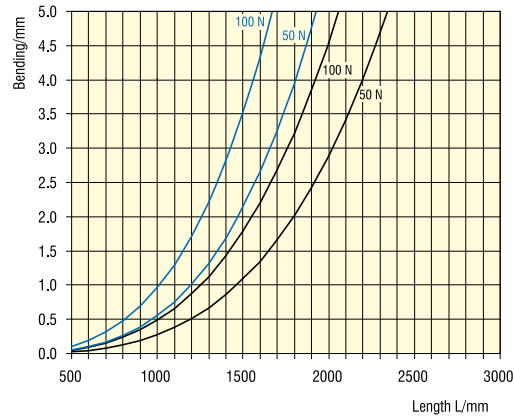
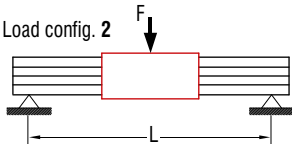

## Dimensioned drawings

LFS-12-10 with slides WS 8

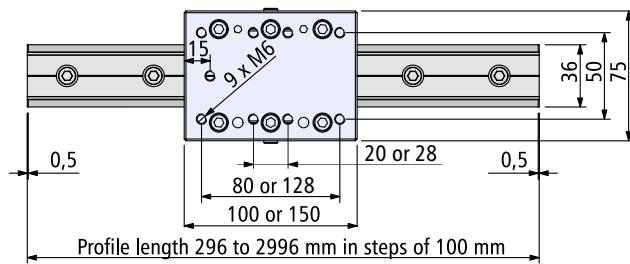
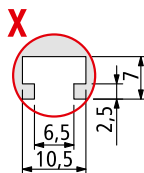
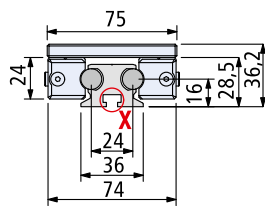

LFS-12-10 with trolley LW 4

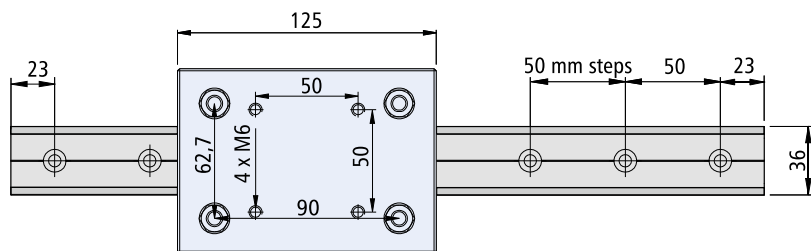
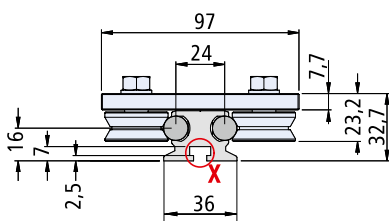

LFS-12-10 with dual track set

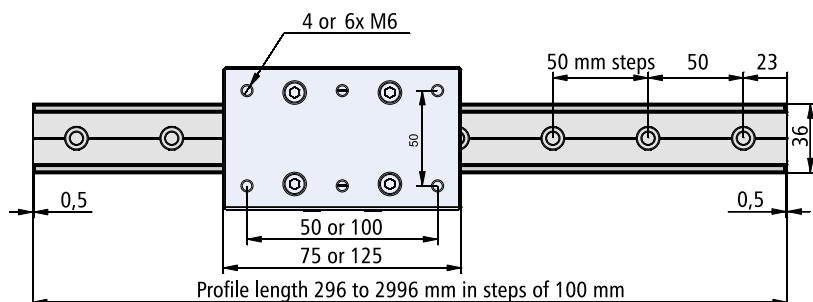
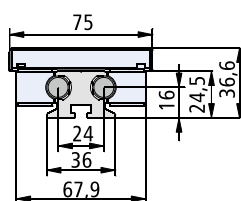

# Accessories

## Tapped rail

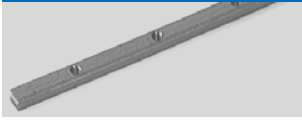

### M6 tapped rail

- 10 x 4 mm
- galvanised
- M6 Ra 50 mm
- VE 3 units at 1 m

Part no.: **209 011**

## Sliding nuts



### M6 sliding nut (Figure 1)

- L 25 x W 10 x H 3.5 mm
- galvanised
- VE 100 unit
- all except PT/RE 40, 65

Part no.: **209 001 0005**

### 2 x M6 sliding nuts (Figure 2)

- L 45 x W 10 x H 3.5
- galvanised
- VE 50 unit
- for all except PT/RE 40, 65

Part no.: **209 002 0004**

### 2 x M6 sliding nuts (Figure 2)

- L 45 x W 13 x H 6 mm
- galvanised
- 2 x M6 Ra 25 mm
- VE 25 unit
- for PT/RE 40, 65

Part no.: **209 005 0001**

### Angle sliding nut

#### 2 x M6 (Figure 3)

- galvanised
- VE 25 units
- for all except PT/RE 40, 65

Part no.: **209 021 0003**

### Special angle sliding nut

#### 3 x M6 (Figure 4)

- galvanised, VE 25 unit
- for all except PT/RE 40, 65

Part no.: **209 022 0003**

## Sliding nuts



### M5 sliding nuts

- galvanised • VE 20 unit
- for all except PT25, PT 50, PS 200, RE 40 and RE 65
- (securing only possible from above)

#### with spring

Part no.: **209005 0002**

(M5/Figure 1)

Part no.: **209005 0003**

(M6/Figure 2)

#### with large chamfer

Part no.: **209005 0004**

(M6/Figure 3)

#### in rhombus shape

Part no.: **209005 0005**

(M5/Figure 4)

Part no.: **209005 0006**

(M6/Figure 5)

## Linear ball bearing



for steel shafts  $\varnothing$  12 mm

### Linear ball bearing large

- L80 x W20 x H19 mm, VE 2 units

Part no.: **222 002 0001**

### Linear ball bearing medium

- L60 x W20.5 x H17.8 mm, VE2 units

Part no.: **222 000**

### Linear ball bearing small

- L40 x W20 x H19 mm, VE 2 units

Part no.: **222 001**

## Grease/grease gun

### Grease

Part no.: **299 031**

### Impact press for grease and oil

Part no.: **931 170**

## Guide shafts



### Guide shaft SF 12/SF 16

- precision steel shafts
- $\varnothing$  12 or 16 mm, length 3 m
- hardened and ground
- with M5 blind hole tapping (SF12) or M6 (SF16) in 100 mm raster or with drilled holes for M4 (SF 12) or M5 (SF 16) in 100 mm raster

Part no.: **220019 0299**

(SF12, 3m, with blind holes for M5)

Part no.: **220020 0299**

(SF12, 3m, with stepped holes for M4)

Part no.: **220023 0299**

(SF16, 3m, with stepped holes for M5)

Part no.: **220024 0299**

(SF16, 3m, with blind holes for M6)

## Rollers



### Roller $\varnothing$ 20 mm for SF 12

- with M4 tapped drilling
- VE 2 units

Part no.: **222 010**

## Rollers



### Roller $\varnothing$ 21 mm

- concentric
- VE 2 units

Part no.: **222 003**

- eccentric
- VE 2 units

Part no.: **222 004**

### Roller $\varnothing$ 31 mm

- concentric
- VE 2 units

Part no.: **222 006**

- eccentric
- VE 2 units

Part no.: **222 007**

Space for your notes

# Drive elements

## Overview

Ball screw spindles $\varnothing$ 12 - 25 mm	B-28
Plastic nuts	B-29
Ball screw nut with single-path return	B-30
Clamping blocks for nuts with single-path return	B-31
Ball screw nut with complete ball return	B-32
Flange bearings	B-33

### Information

Ball screw nuts supplied by isel Germany are high-quality, precise and wear-free (hardened and ground). Combined with ball screw spindles, ball screw nuts ensure that rotary motion is converted into linear motion at extremely low values of friction.

The ball screw nut is positioned and held in the clamping block using a stud screw. The ball screw nuts contain multiple circulating balls and an internal ball return mechanism.

Adjustment of the clamping block stud screw allows the ball screw spindle to move freely, without backlash.

Repeat accuracy is less than 0.01 mm on a length of 300 mm. The linear drive is lubricated via the grease nipple on the clamping block.

Ball screw spindles are roll manufactured using modern machines prior to hardening and polishing.

Our linear drives are technically advanced and have proven themselves over a period of more than 20 years of practical application.

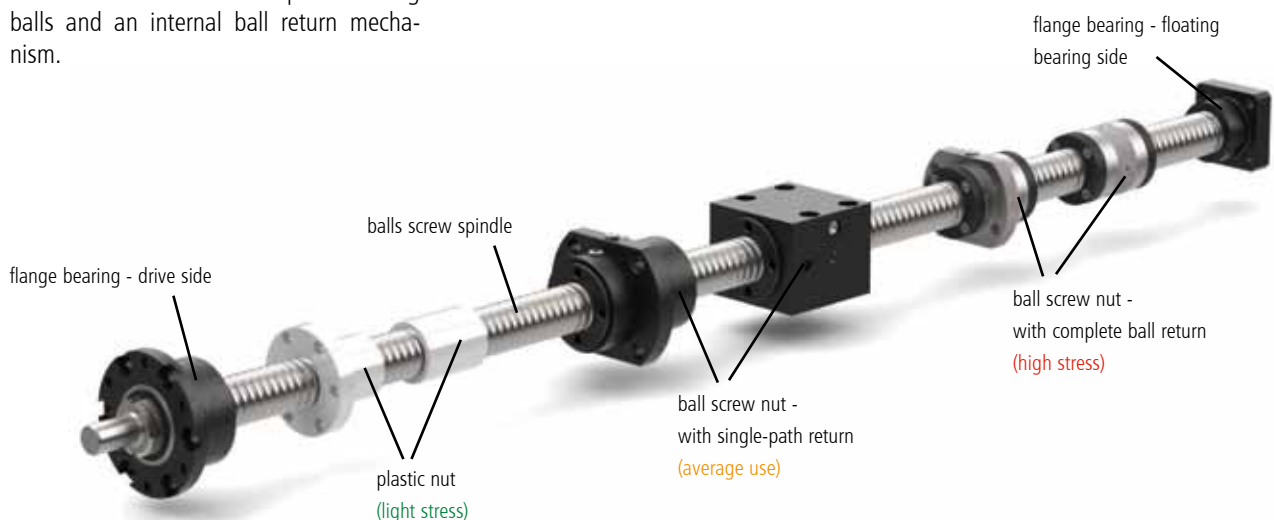



# Contract Manufacturing

With more than 1 million units soled, "isel" has created core competence in the area of ball screws. Our drives are technically mature and have proved themselves in many applications in practical use. The specialist skills of our highly qualified employees are a significant contributing factor on our path to creating technically perfect and economically successful solutions. isel Germany AG offers products to meet every special customer requirement. Thanks to our very modern manufacturing plants, we are able to carry out all work processes (rolling, hardening and polishing) efficiently and according to the customer's specifications. They precisely meet the special requirements that you give to us. Please get in contact with us or give us a call to discuss your area of application or individual case. You will find us an attentive and skilled partner. Our in-house design department checks all technical requirements and works in close collaboration with the production engineers to ensure your order can be quickly and flexibly integrated into the production process.

Visit us on our website and look at our current product video:



The company isel Germany AG has been manufacturing ball screw spindles on modern CNC controlled production machines also using robotics for over 25 years.

Included amongst our long-standing clients are companies from the areas of

- machine and equipment construction
- electronics industry
- wood-working
- medical technology
- semiconductor industry
- training and other related areas



## Ball screw spindles

Ø 12, 16, 20, 25 mm



## Features

- rolled, hardened and polished
- material CF 53, inductively hardened (HRC 60±2)
- length up to 3,052 mm available (Special length on request!)
- end machining to isel standard or according to customers specifications

## Available length Ø 12 mm

Without end machining in a grid of 100 mm

- 252 up to 3,052 mm

## Two-sided end machining

in a grid of 100 mm

- 252 mm up to 3,052 mm

## Available length Ø 16 mm

Without end machining in a grid of 100 mm

- 352 up to 3,052 mm

## Two-sided end machining

in a grid of 100 mm

- 368 mm up to 3,068 mm

## Available length Ø 20 mm

Without end machining in a grid of 100 mm

- 252 up to 3,052 mm

## Two-sided end machining

in a grid of 100 mm

- 252 up to 3,052 mm

## Available length Ø 25 mm

Without end machining in a grid of 100 mm

- 500 up to 3,000 mm

## Two-sided end machining

in a grid of 100 mm

- 295 up to 2,995 mm

## Ordering key

2 1 1 X X X X X X X		Lengths
		e.g. <b>045</b> = 452 mm
		<b>086</b> = 868 mm
		<b>305</b> = 3,052 mm
		(rounded to the final digit)
Diameter	Spindle pitch	End machining
2 = 12 mm	2 = 2,5 mm (only for Ø 12, 16mm)	0 = not machined
3 = 16 mm	3 = 4 mm (only for Ø 16 mm)	1 = one-sided
4 = 25 mm	4 = 5 mm	2 = both sided (only for Ø 12, 25 mm)
5 = 20 mm	5 = 10 mm (not at Ø 12 mm)	5 = both sided (only for Ø 16, 20 mm)
	6 = 20 mm (not at Ø 12 mm)	suitable for all feeds
		(Aluminium profile length +78 mm)

See „available length“ for permissible combinations!

## Dimensioned drawing

	Spindle pitch	L [max.]	L1	L2	L3	L4	L5	M	D1	D2	D3	D4
Ø 12	2.5 / 5	3,052	10	19	34.5	19	-	M8x 1	6.35 h7	8 h6	-	7 h6
Ø 16	2.5 / 4 / 5 / 10 / 20	3,052	18	31	52	28	-	M10 x 0.75	8 h7	10 h6	-	12 h6
Ø 20	5 / 10 / 20	3,052	20	32	55	27.5	-	M12x 1	10 h7	12 h6	-	12/14 h6
Ø 25	5 / 10 / 20	3,052	25	37	69	26	16	M17x 1	15 h7	17 h6	15 j6	19 h11

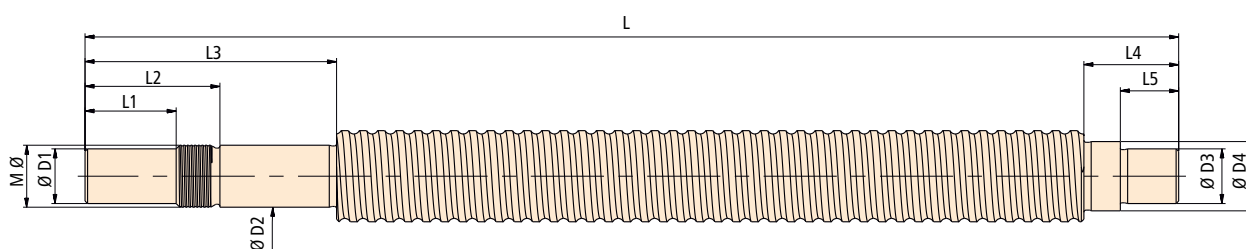

# Plastic nuts round- or flange version for isel standard spindles

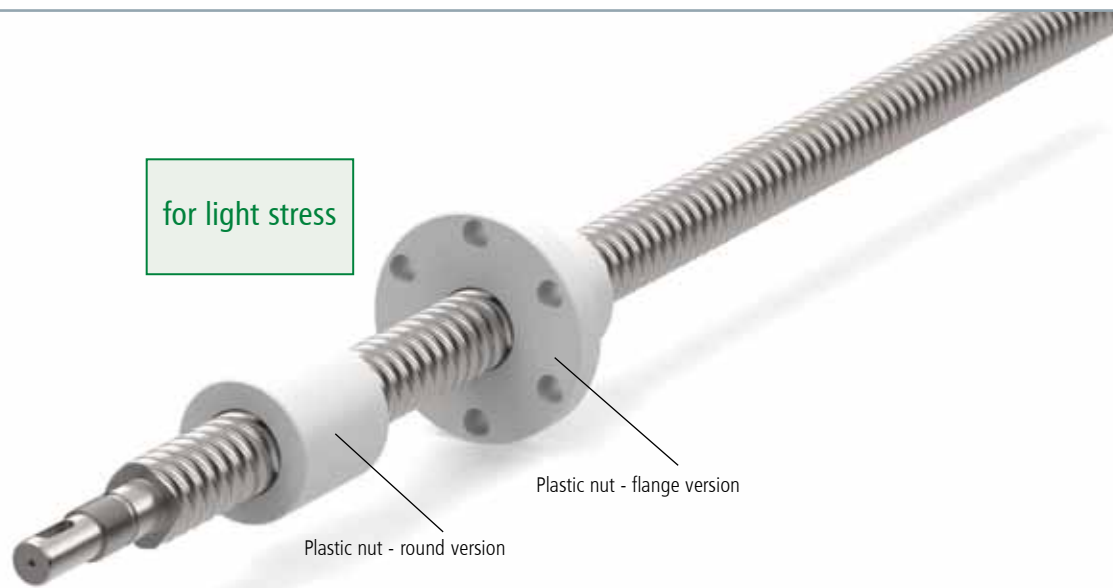

## Technical data

### Round nut

Item-No.	thread d1 x P	b1	d2	F axial (at V <sub>max.</sub> ) [N]	V <sub>max.</sub> [mm/s] [feed]
213612 0025	12 x 2.5	25	24	123	33
213612 0050	12 x 5	25	24	123	66
213616 0050	16 x 5	30	28	179	50
213616 0100	16 x 10	30	28	179	100
213616 0200	16 x 20	30	28	179	199
213620 0050	20 x 5	35	33	238	40
213620 0100	20 x 10	35	33	235	80
213620 0200	20 x 20	35	33	235	159
213625 0050	25 x 5	40	32	381	32
213625 0100	25 x 10	40	32	381	64
213625 0200	25 x 20	40	32	386	127

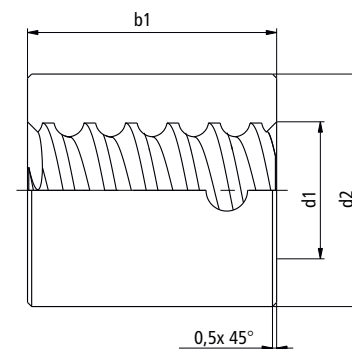

### Flange nut

Item	thread d1 x P	d2	d3	d4	d5	b1	b2	F axial (at V <sub>max.</sub> ) [N]	V <sub>max.</sub> [mm/s] [feed]
213812 0025	12 x 2.5	24	42	34	5	25	8	123	33
213812 0050	12 x 5	24	42	34	5	25	8	123	66
213816 0050	16 x 5	28	48	38	6	30	10	179	50
213816 0100	16 x 10	28	48	38	6	30	10	179	100
213816 0200	16 x 20	28	48	38	6	30	10	179	199
213820 0050	20 x 5	33	55	45	7	35	10	238	40
213820 0100	20 x 10	33	55	45	7	35	10	235	80
213820 0200	20 x 20	33	55	45	7	35	10	235	159
213825 0050	25 x 5	32	55	45	7	40	10	381	32
213825 0100	25 x 10	32	55	45	7	40	10	381	64
213825 0200	25 x 20	32	55	45	7	40	10	386	127

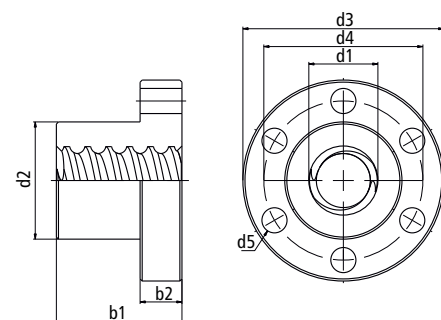

# Ball screw nut with single-path ball return

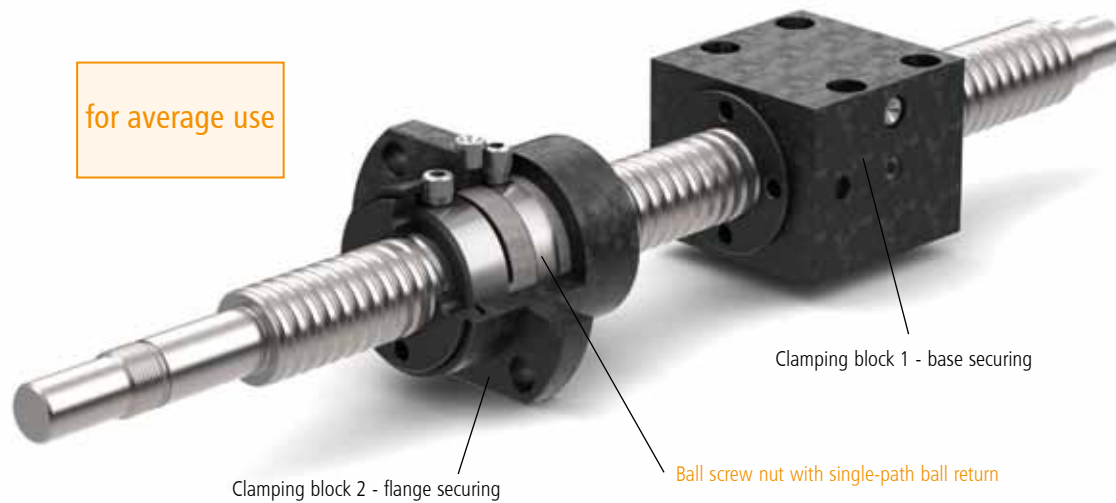

## Ordering data

Ø	Item-No.	spindle pitch	D	L	dynamic load [N]	static load [N]
12	213412 0003	2.5	24	37.5	3,000	1,900
	213412 0005	5	24	37.5	2,000	1,300
16	213503	2.5	28	50	3,500	5,500
	213514	4	28	50	4,600	7,200
	213505	5	28	50	4,600	7,200
	213510	10	28	50	4,200	6,500
	213520	20	28	50	2,500	1,900
20	213420 0005	5	33	50	9,000	5,000
	213420 0010	10	33	50	8,000	4,500
	213420 0020	20	33	50	3,500	2,200
25	213700 0005	5	38	50	5,100	12,600
	213700 0010	10	38	50	5,100	12,600
	213700 0020	20	38	70	3,570	8,800

## Features ball screw nuts

- material 16MnCr5, sharpened
- version as round nuts
- pitches: 2.5 / 5 / 10 / 20 mm
- with integrated end-cap ball return
- the version with pitch 20 mm is supplied with scrapers

## Dust Seal

- for ball screw nuts Ø 12, 16, 20, 25 mm (QTY 2 pieces)

Ø 12 mm Item-No.: [213500 0003](#)

Ø 16 mm Item-No.: [213500 0001](#)

Ø 20 mm Item-No.: [213500 0002](#)

Ø 25 mm Item-No.: [213700 9000](#)

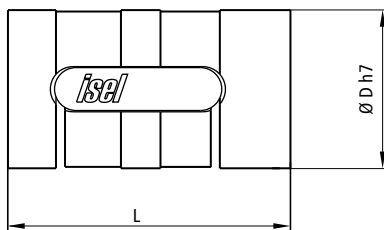

# ... and suitable clamping blocks

## Features clamping blocks

- material steel, gunmetal finish
  - versions for recirculating ball spindles  
 $\varnothing$  12, 16, 20, 25 mm
  - clamping blocks for base and flange securing
- Nut pitches  
 2.5/5 mm ( $\varnothing$  12 mm)  
 2.5/4/5/10 and 20 mm ( $\varnothing$  16 mm)  
 5/10 and 20 mm ( $\varnothing$  20 mm)  
 5/10 and 20 mm ( $\varnothing$  25 mm)

## Ordering data and dimensioned drawings of the clamping blocks

### Base securing

	Item-No.	M	L	B	H	H1	L1	L2	L3	Clamping nut
$\varnothing$ 12	213400	24	37.5	44	29	14.5	7	20	31	-
$\varnothing$ 16	213500	28	54	47	33	16.5	14.5	25	35	-
$\varnothing$ 20	213600	33	61.5	53	40	20	10	30	40	1x
$\varnothing$ 25 - pitch 5/10	213700 9001	38	60	60	49.5	25	10	30	46	1x
$\varnothing$ 25 - pitch 20	213700 9002	38	80	60	50	25	10	50	46	1x

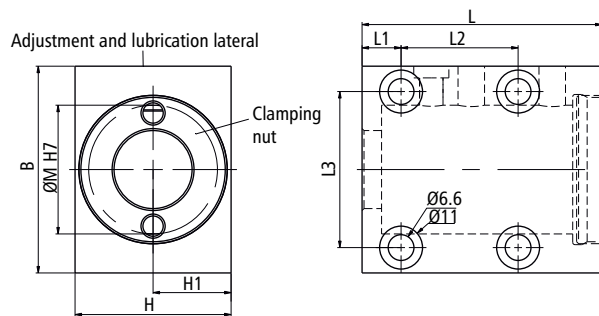

### Flange securing

	Item-No.	M	L	B	H	d	T	D1	D2	D3	L1	L2	Clamping nut
$\varnothing$ 12	213401	24	37.5	53	42	4.5	45	35	37 g6	35	3	24.5	-
$\varnothing$ 16	213501	28	50	62	48	6.6	51	39	40 g6	39	11.6	28.4	-
$\varnothing$ 20	213601	33	60.5	67	53	6.6	56	44	45 g6	44	16	34.5	1x
$\varnothing$ 25 - pitch 5/10	213700 9003	38	60	80	62	9	65	49	50 f9	50 f9	32.25	17.75	1x
$\varnothing$ 25 - pitch 20	213700 9004	38	80	80	62	9	65	49	50 f9	50 f9	52.25	17.75	1x

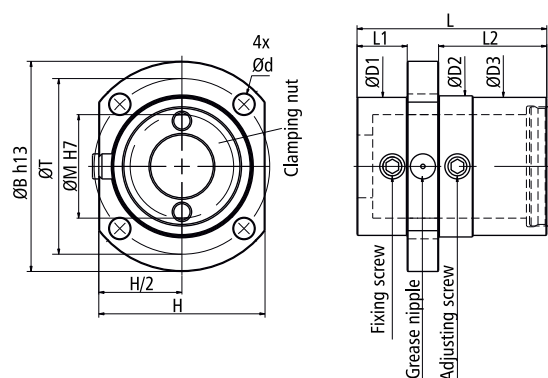

# Ball screw nut with complete ball return

for high loads

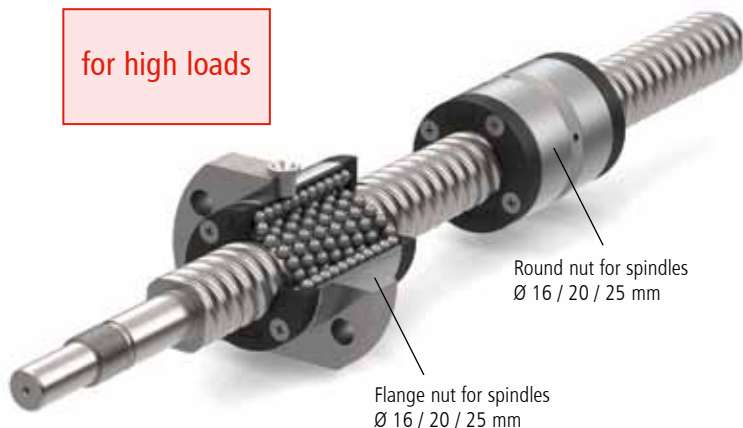

## Features

- material 16MnCr5, sharpened
- version as round nut or flange nut
- pitch: 20 mm
- with integrated end-cap ball return
- integrated dust seal function in the deflector

## Dimensioned drawings

Round nut

Ø	Item-No.	pitch	d2	d1	Ø D <sub>h7</sub>	L	L <sub>1</sub>	M	L <sub>2</sub>	dynamic load factor	static load factor
16	211336 0020	20	16	10	30	45,5	33,5	M8 x 0,75	22,5	13.000 N	29.000 N
20	211356 0020	20	20	14	35	46,5	34,5	M8 x 0,75	25,5	15.000 N	35.000 N
25	211346 0020	20	25	21	40	50	35	M10 x 0,75	28,3	16.000 N	40.000 N

Flange nut

Ø	Item-No.	pitch	d2	d1	D1 g <sub>6</sub>	LB	L1	L3	L8 h <sub>13</sub>	D4	D6 h <sub>13</sub>	D5	dynamic load factor	static load factor
16	211236 0020	20	16	10	30	45,5	10	6	40	38	48	6x Ø5,5	13.000 N	29.000 N
20	211256 0020	20	20	14	35	46,5	10	11	44	47	58	4x Ø 6,6	15.000 N	35.000 N
25	211246 0020	20	25	21	40	50	10	12,5	48	51	62	4x Ø6,6	16.000 N	40.000 N

Round nut

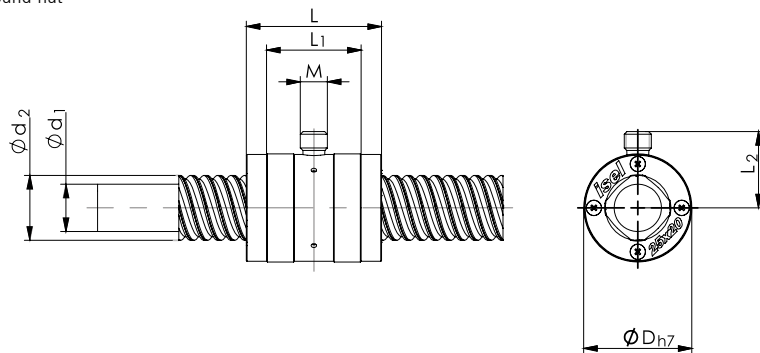

Flange nut

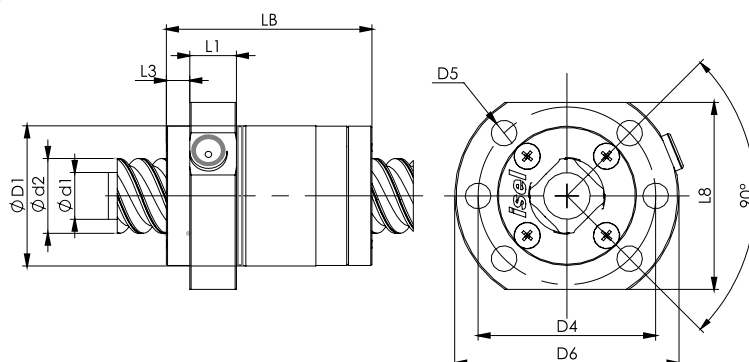

# Flange bearings



flange bearing - drive side



flange bearing - floating bearing side

## Features

- bearing, spindle drive side (fixed bearing side) and the spindle floating bearing side
- flange bearing, drive side: bushing with two pressed angular contact ball bearings in an O-configuration
- flange bearing, floating bearing side (counter-bearing): bushing with pressed needle bearing

## Ordering data and dimensioned drawings

Drive side and locking nut

	Version	Item-No.	B	L	L1	D1	D2	T1	T2	G1	G2	d	Thread
Ø 12	angular	216504 0030	40	19.5	8	35	8	38.2	-	45°	90°	4x Ø 4.5	-
Ø 16	angular	216504 0001	45	23	6	35	10	45	-	45°	90°	4x Ø 12 x 4U / Ø 7	-
Ø 16	round	216504 0003	62	23	6	35	10	45	54	45°	90°	4x Ø 12 x 4U / Ø 7	4x M6
Ø 20	round	216504 0031	64	23	8	39.5	12	50	54	45°	90°	4x Ø 12 x 4U / Ø 7	4x M6
Ø 25	round	216504 0006	72	34	8	53	17	62	62	30°	60°	6x Ø 12 x 4U / Ø 7	6x M6

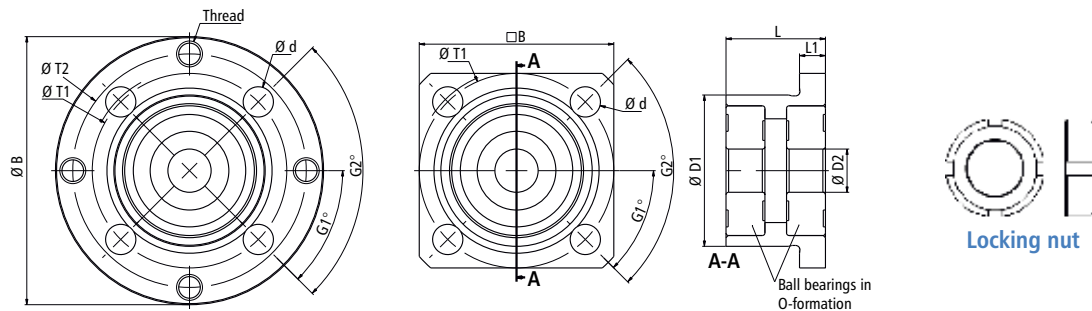

Floating bearing side

	Item-No.	B	L	L1	L2	L3	L4	D1	D2	T	d
Ø 12	216504 0032	35	20	8	6	6.5	0.5	28	7	38.2	Ø7.5 x 4U Ø4.5
Ø 16	216504 0002	45	29	12	4.5	9.5	0.5	35	12	45	Ø12 x 4U Ø7
Ø 20	216504 0033	50	29.5	12	4.5	5	1.5	35	12	50	Ø12 x 4U Ø7
Ø 25	216504 0005	45	29	12	8	10	0	35	15	45	Ø12 x 4U Ø7

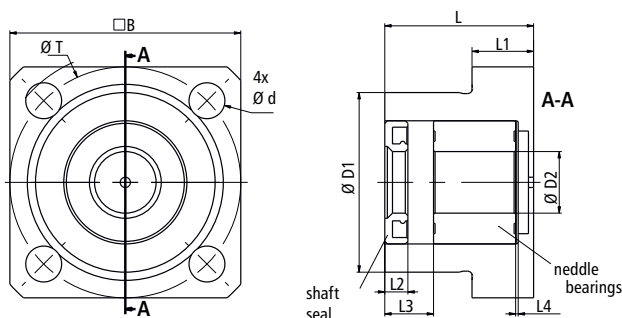

## LES functional overview

B-44

## LES 4

with spindle drive

B-46

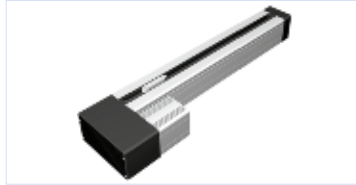

## LES 6

with spindle drive

B-48



## LES 5

with spindle drive

B-50



## Calculations

B-52

## Combination examples

B-54

## Motor modules

B-56

## Clutch housing

B-57

## Motor leads

B-58

Installation kit with angular transmission

B-62

## Slots/crossbench plates

B-64

## T-slot plates

B-67

## Angles brackets

B-68



## Accessories

B-71



# Linear units

## Overview

LEZ functional overview		B-74
LEZ 1 with toothed belt drive		B-76
LEZ 2 with toothed belt drive		B-80
LEZ 3 with toothed belt drive		B-82
Accessories		B-86
Example in use		B-87



CAD data can be found on [www.isel.com](http://www.isel.com) and



# Functional overview

at example LES 5

Plastic cap  
electromagnetically shielded

Clamping surface  
milled flat

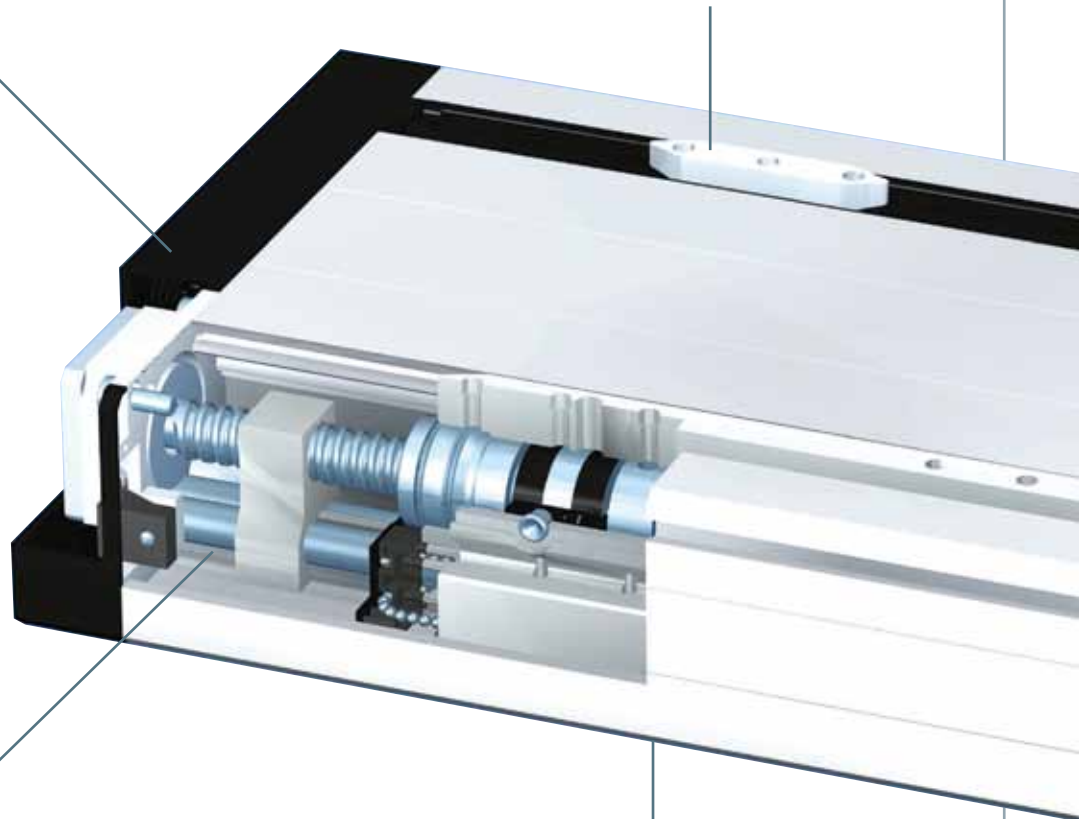

Shaft housing outline  
precision milled

Profile underside  
milled flat



- end position buffering both sides with soft PVC parabolic springs
- counter-bearing with 2 needle sleeves

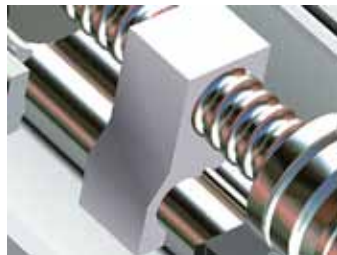

- spindle support from a profile length of 1500 mm without limiting the process range

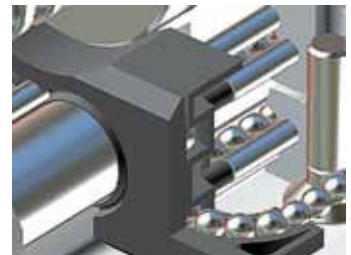

- recirculating ball in patented aluminium linear slides
- glass fibre reinforced loop components with scrapers

# Functional overview

at example LES 5

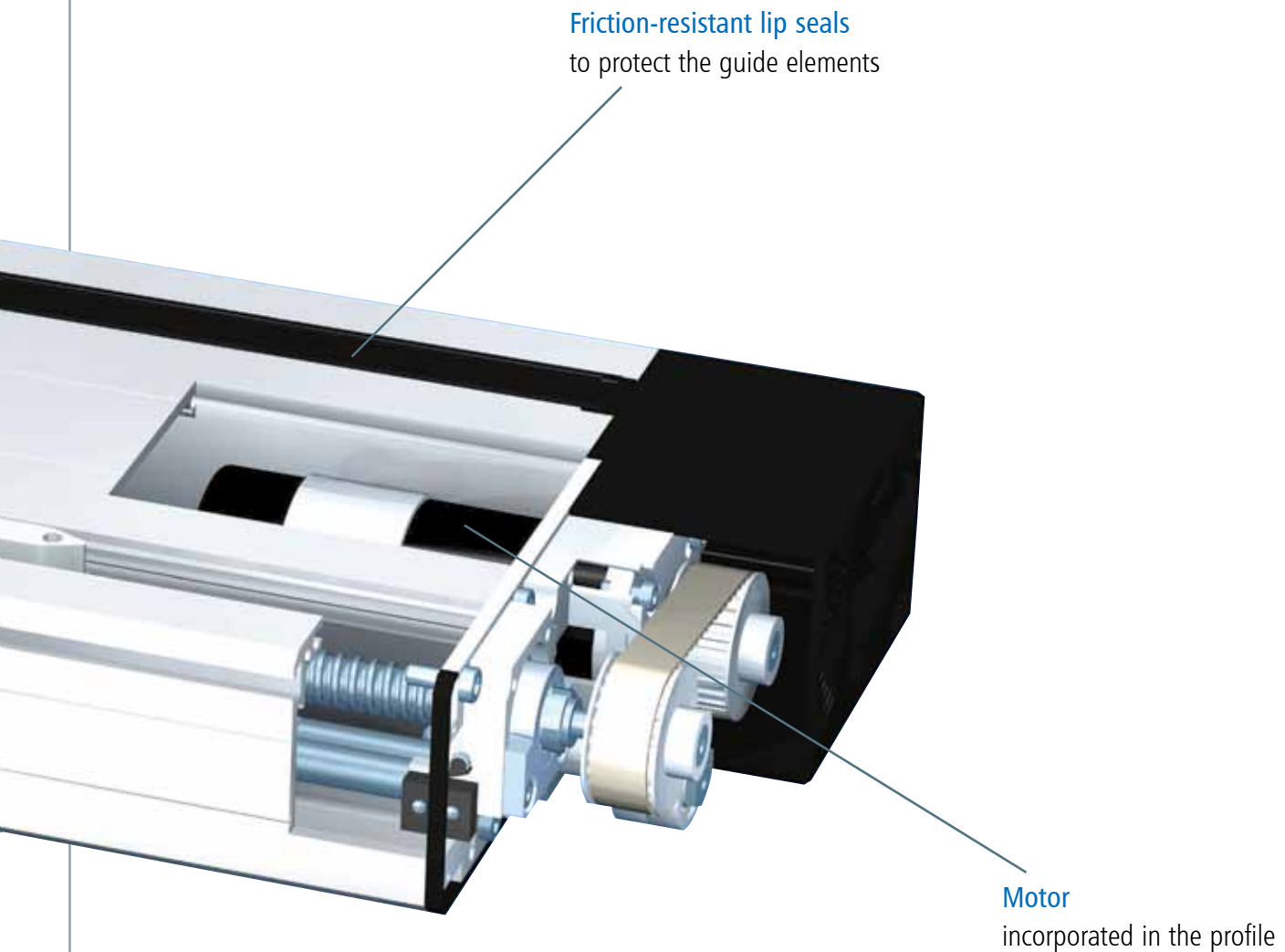

- preset play-free recirculating ball nut with scrapers
- central lubrication system for recirculating ball nut and circulations

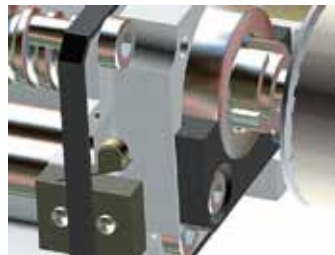

- integrated overrun limit switch
- spindle bearing with angular contact bearings
- axially free from play by means of self-locking special nuts



- belt return and connecting electronics covered completely by protective cap

# Linear units with spindle drive

# LES 4

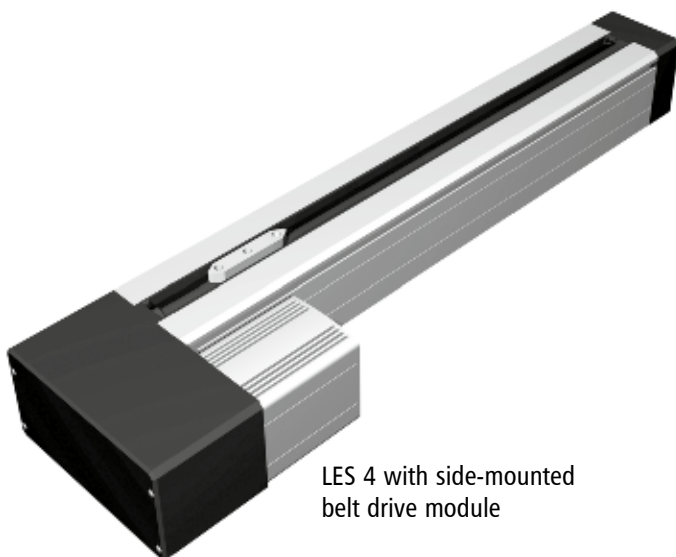

LES 4 with side-mounted belt drive module

## Features

- aluminium shaft housing profile W75 × H75 mm, naturally anodised
- clamping area and profile underside milled flat
- with 2 precision steel shafts Ø 12 h6, material Cf53, hardness 60 ± 2 HRC
- aluminium shaft slides WS 5/70, 2 x WS 5/70 (70 mm long), adjustable for no play, central lubrication system
- recirculating ball drive 2.5/4/5/10 and 20 mm pitches
- profile sealing with friction-resistant lip seals
- cast aluminium end plates
- with 2 limit or reference switches, repeat accuracy ± 0.02 mm
- sealed angular contact bearings in drive - steel flange

## Ordering key

2 3 4 X X X 0 X X X

### Drive

- 0 = Preparation Direct drive modules
- 1 = Preparation Belt drive module

### Shaft slides

- 0 = 1 Shaft slides 70 mm
- 1 = 1 Shaft slides 200 mm
- 2 = 2 Shaft slides 70 mm

### Profile length (L1)

e.g. 029 = 290 mm (min.)  
299 = 2990 mm (max.)

(rounded to the last digit)

Standard profile lengths available in 100 mm raster

### Recirculating ball drive

- 0 = without
- 1 = Pitch 2.5 mm
- 2 = Pitch 4.0 mm
- 3 = Pitch 5.0 mm
- 4 = Pitch 10 mm
- 5 = Pitch 20 mm
- 6 = Pitch 20 mm (with complete ball return)

## Options:

- black anodized aluminium profile
- electromagnetic brakes in the motor module or in drive spindle extension
- steel slide LS2 (Part no. 223007)
- external limit switch attachment set (see accessories)

## Available on request:

- length measuring system
- bellows gaiter cover
- assembly left of the motor module

## Drive modules

see pages B-46 et seq. of the catalogue



## Technical specification

### Aluminium profile

Aluminium profile LES 4	
Moment of inertia I <sub>x</sub>	107.711 cm <sup>4</sup>
Moment of inertia I <sub>y</sub>	125.843 cm <sup>4</sup>
*Centre of gravity <small>see dimensioned drawing</small>	33.23 mm
Cross-sectional area	18.81 cm <sup>2</sup>
Material	AlMgSi0, 5F22
Anodising	E6/EV1
Weight with steel shafts	6.2 kg/m
Weight with steel shafts and spindles	7.6 kg/m

## No load running torques

No load torques (Ncm)					
Speed (rpm)	Spindle pitch				
	2.5	4	5	10	20
500	15	15	16	17	18
1500	19	19	19	20	21
3000	23	24	24	25	26

# Linear units with spindle drive

## LES 4

### Bending

Load config. 1

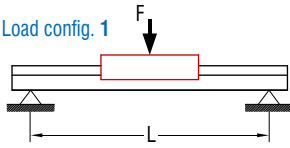

Load config. 2

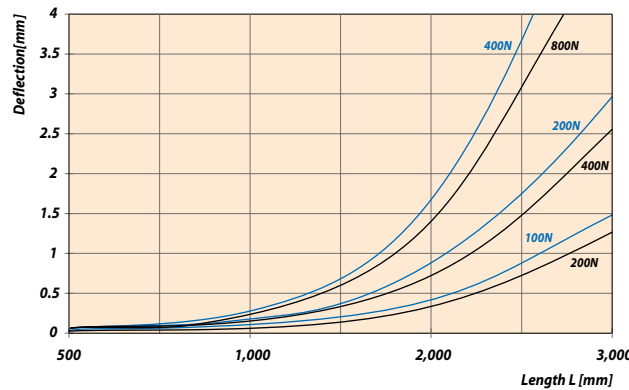
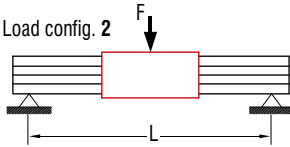

### Load factors

$$F_r(\alpha) = \frac{F_2}{\cos \alpha}$$

$$F_r(\alpha) = \frac{F_1}{\sin \alpha}$$

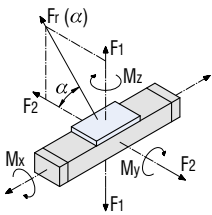

LES 4 with one WS 5/70	
$C_0$	2,576.65 N
C	1,461.14 N
$F_1$ stat.	2,200.67 N
$F_1$ dyn.	1,247.93 N
$F_2$ stat.	2,576.65 N
$F_2$ dyn.	1,461.14 N
$M_x$ stat.	36.45 Nm
$M_y$ stat.	82.16 Nm
$M_z$ stat.	96.20 Nm
$M_x$ dyn.	20.67 Nm
$M_y$ dyn.	46.59 Nm
$M_z$ dyn.	54.55 Nm

LES 4 with two WS 5/70	
$C_0$	4,954.5 N
C	2,809.5 N
$F_1$ stat.	4,231.5 N
$F_1$ dyn.	2,398.5 N
$F_2$ stat.	4,954.5 N
$F_2$ dyn.	2,809.5 N
$M_x$ stat.	44.7 Nm
$M_y$ stat.	126.945 Nm
$M_z$ stat.	148.635 Nm
$M_x$ dyn.	25.2 Nm
$M_y$ dyn.	71.955 Nm
$M_z$ dyn.	84.285 Nm

### permissible spindle speeds

LES 4 / 5 / 6	Spindle pitch p [mm]	max. permissible feed speed v permissible [mm/s]				
		2.5	4	5	10	20
490	4000	167	267	333	667	1333
990	3000	125	200	250	500	1000
1390	1500	63	100	125	250	500
1490 *	3000	125	200	250	500	1000
1990 *	1650	69	110	138	275	550
2490 *	1050	44	70	88	175	350
2990 *	750	31	50	63	125	250

\* with spindle support

### dimensioned drawing

process travel

at 1 x WS 5/70 = L1 -150 mm  
at 2 x WS 5/70 = L1 -280 mm

motor module dimensions see pages B-47  
external limit switches see pages B-61

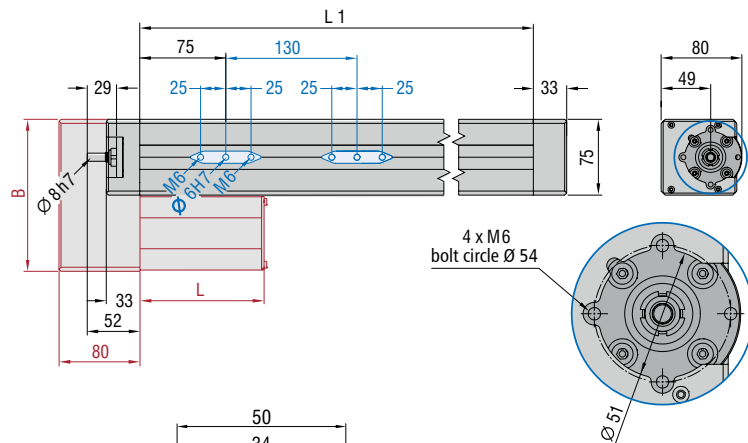

### dimensioned drawing

Aluminium profile

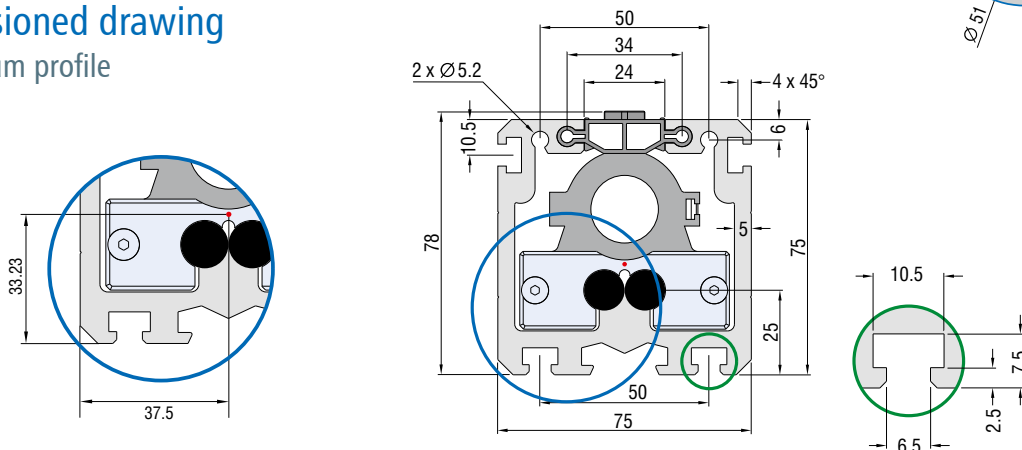

calculations on the „theoretical critical speed“ and the „drive size“ can be found at [www.isel.com/en/products/mechanics/linear-units/linear-units-les4](http://www.isel.com/en/products/mechanics/linear-units/linear-units-les4)

# Linear units with spindle drive

# LES 6



LES 6 with side belt drive module

## Features

- aluminium shaft housing profile W150 × H75 mm, naturally anodised
- clamping area and profile underside milled flat
- with 4 precision steel shafts Ø 12 h6, material Cf53, hardness 60 ± 2 HRC
- aluminium shaft slides WS 5/70, 2 x WS 5/70 (70 mm long), adjustable for no play, central lubrication system
- recirculating ball drive 2.5/4/5/10 and 20 mm pitches
- profile sealing with friction-resistant lip seals
- cast aluminium end plates
- with 2 limit or reference switches, repeat accuracy ± 0.02 mm
- sealed angular contact bearings in drive - steel flange

## Ordering key

2 3 4 X X X 0 X X X

### Drive

- 6 = Preparation Direct drive modules
- 7 = Preparation Belt drive module

### Shaft slides

- 0 = 2 Shaft slides 70 mm
- 1 = 2 Shaft slides 200 mm
- 2 = 4 Shaft slides 70 mm

### Profile length (L1)

- e.g. 029 = 290 mm (min.)
- 299 = 2990 mm (max.)

(rounded to the last digit)

Standard profile lengths available in 100 mm raster

### Recirculating ball drive

- 0 = without
- 1 = Pitch 2.5 mm
- 2 = Pitch 4.0 mm
- 3 = Pitch 5.0 mm
- 4 = Pitch 10 mm
- 5 = Pitch 20 mm
- 6 = Pitch 20 mm (with complete ball return)

### Options:

- black anodized aluminium profile
- electromagnetic brake
- steel slides LS2 (Part no. 223007)
- limit switch attachment kit (see accessories)

### To order:

- length measuring system
- bellows gaiter cover
- assembly left of the motor module

## Drive modules

see pages B-46 et seq. of the catalogue



## Technical specification

### Aluminium profile

Aluminium profile LES 6	
Moment of inertia I <sub>x</sub>	707.100 cm <sup>4</sup>
Moment of inertia I <sub>y</sub>	212.200 cm <sup>4</sup>
*Centre of gravity <small>see dimensioned drawing</small>	32.78 mm
Cross-sectional area	30.07 cm <sup>2</sup>
Material	AlMgSi0, 5F22
Anodising	E6/EV1
Weight with steel shafts	11.4 kg/m
Weight with steel shafts and spindles	12.8 kg/m

## No load running torques

No load torques (Ncm)					
Speed (rpm)	Spindle pitch				
	2.5	4	5	10	20
500	17	17	18	20	21
1500	20	20	22	24	25
3000	24	25	26	29	30

# Linear units with spindle drive

## LES 6

### Bending

■ Load config. 1

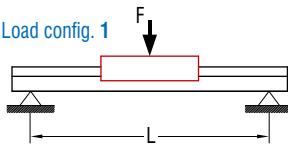

■ Load config. 2

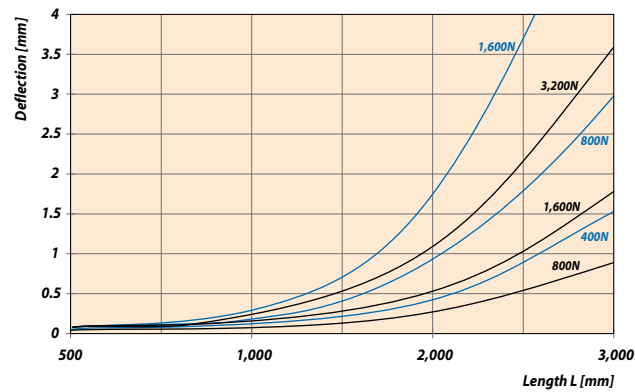
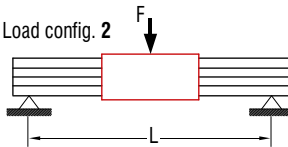

### Load factors

$$Fr(\alpha) = \frac{F_2}{\cos \alpha}$$

$$Fr(\alpha) = \frac{F_1}{\sin \alpha}$$

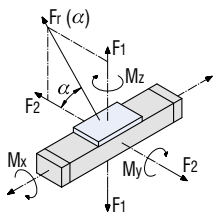

LES 6 with two WS 5/70	
C <sub>0</sub>	5,153.30 N
C	2,319.41 N
F <sub>1 stat.</sub>	4,401.33 N
F <sub>1 dyn.</sub>	1,980.96 N
F <sub>2 stat.</sub>	5,153.30 N
F <sub>2 dyn.</sub>	2,319.14 N
M <sub>x stat.</sub>	211.54 Nm
M <sub>y stat.</sub>	164.31 Nm
M <sub>z stat.</sub>	192.39 Nm
M <sub>x dyn.</sub>	95.21 Nm
M <sub>y dyn.</sub>	73.95 Nm
M <sub>z dyn.</sub>	86.59 Nm

LES 6 with four WS 5/70	
C <sub>0</sub>	6,606 N
C	3,746 N
F <sub>1 stat.</sub>	5,642 N
F <sub>1 dyn.</sub>	3,198 N
F <sub>2 stat.</sub>	6,606 N
F <sub>2 dyn.</sub>	3,746 N
M <sub>x stat.</sub>	211.575 Nm
M <sub>y stat.</sub>	366.73 Nm
M <sub>z stat.</sub>	429.39 Nm
M <sub>x dyn.</sub>	119.925 Nm
M <sub>y dyn.</sub>	207.87 Nm
M <sub>z dyn.</sub>	243.49 Nm

### permissible spindle speeds

LES 4 / 5 / 6	Spindle pitch [mm]	2.5	4	5	10	20
		max. permissible feed speed v permissible [mm/s]				
Profil length L [mm]	max. permissible feed speed [rpm]					
490	4000	167	267	333	667	1333
990	3000	125	200	250	500	1000
1390	1500	63	100	125	250	500
1490 *	3000	125	200	250	500	1000
1990 *	1650	69	110	138	275	550
2490 *	1050	44	70	88	175	350
2990 *	750	31	50	63	125	250

\* with spindle support

### dimensioned drawing

process travel  
at 2xWS 5/70 = L1 -150 mm  
at 4xWS 5/70 = L1 -280 mm

motor module dimensions see pages B-47  
external limit switches see pages B-61

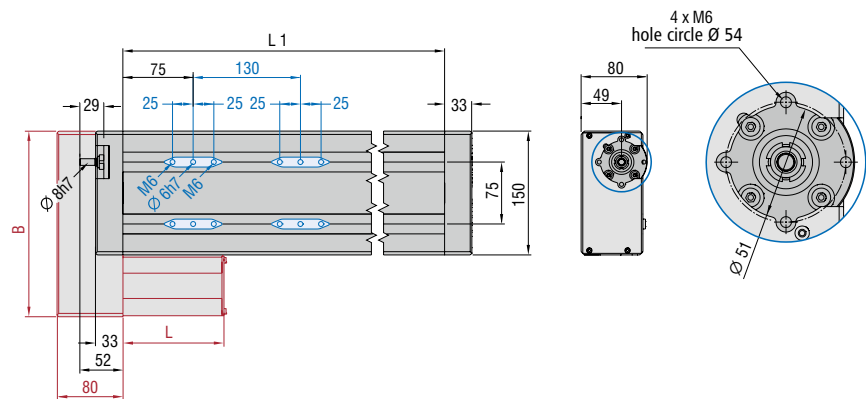

### dimensioned drawing Aluminium profile

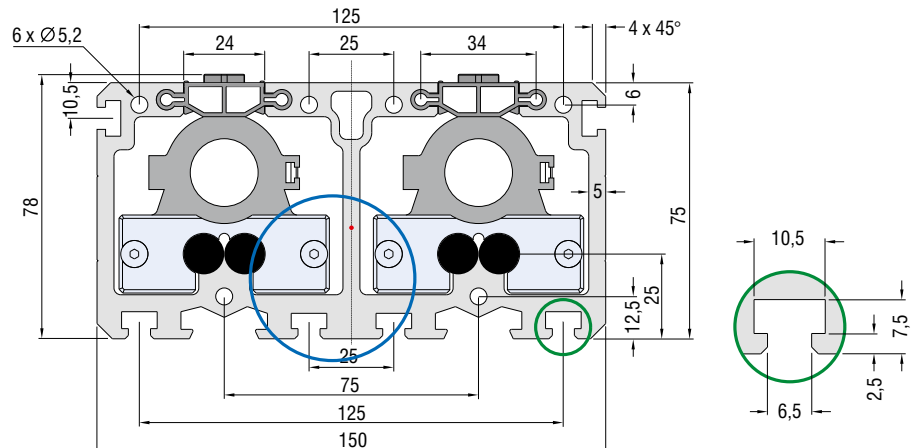
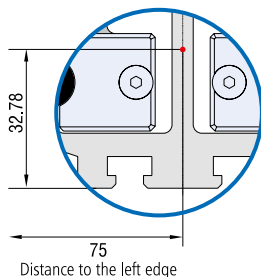

calculations on the „theoretical critical speed“ and the „drive size“ can be found at [www.isel.com/en/products/mechanics/linear-units/linear-units-les6](http://www.isel.com/en/products/mechanics/linear-units/linear-units-les6)

# Linear units with spindle drive

## LES 5



LES 5 with integrated belt drive module

### Features

- aluminium shaft housing profile W225 × H75 mm, naturally anodised
- clamping area and profile underside milled flat
- with 4 precision steel shafts Ø 12 h6, material Cf53, Hardness 60 ± 2 HRC
- aluminium shaft slides WS 5/70, 2 x WS 5/70 (70 mm long), adjustable for no play, central lubrication system
- recirculating ball drive 2.5/4/5/10 and 20 mm pitches
- profile sealing with friction-resistant lip seals
- cast aluminium end plates
- with 2 limit or reference switches, repeat accuracy ± 0.02 mm
- sealed angular contact bearings in drive - steel flange

### Ordering key

2 3 4 X X X 0 X X X

**Drive**

- 3 = Preparation Direct drive modules
- 4 = Preparation Belt drive module

**Shaft slides**

- 0 = 2 Shaft slides 70 mm
- 1 = 2 Shaft slides 200 mm
- 2 = 4 Shaft slides 70 mm

**Profile length (L1)**

e.g. 029 = 290 mm (min.)  
299 = 2990 mm (max.)  
(rounded to the last digit)  
Standard profile lengths available in 100 mm raster

**Recirculating ball drive**

- 0 = without
- 1 = Pitch 2.5 mm
- 2 = Pitch 4.0 mm
- 3 = Pitch 5.0 mm
- 4 = Pitch 10 mm
- 5 = Pitch 20 mm
- 6 = Pitch 20 mm (with complete ball return)

**Options:**

- black anodized aluminium profile
- electromagnetic brake
- steel slides LS2 (Part no. 223007)
- limit switch attachment kit (see accessories)

**Available on request:**

- length measuring system
- bellows gaiter cover

### Drive modules

see pages B-46 et seq. of the catalogue



### Technical specification

#### Aluminium profile

Aluminium profile LES 5	
Moment of inertia I <sub>x</sub>	2,361.654 cm <sup>4</sup>
Moment of inertia I <sub>y</sub>	298.925 cm <sup>4</sup>
*Centre of gravity <small>see dimensioned drawing</small>	33.39 mm
Cross-sectional area	42.49 cm <sup>2</sup>
Material	AlMgSi0, 5F22
Anodising	E6/EV1
Weight with steel shafts	13.8 kg/m
Weight with steel shafts and spindles	15.2 kg/m

### No load running torques

No load torques (Ncm)					
Speed (rpm)	Spindle pitch				
	2.5	4	5	10	20
500	15	15	16	17	18
1500	19	19	19	20	21
3000	23	24	24	25	26



# Linear units with spindle drive

## LES 5

### Bending

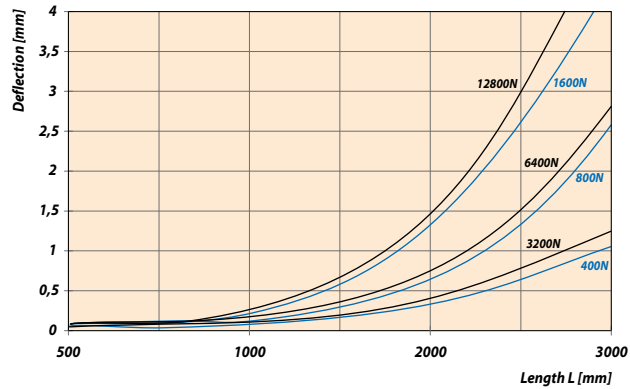
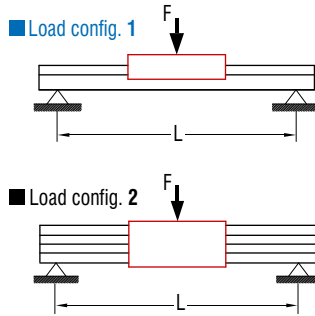

### Load factors

$$F_r(\alpha) = \frac{F_2}{\cos \alpha}$$

$$F_r(\alpha) = \frac{F_1}{\sin \alpha}$$

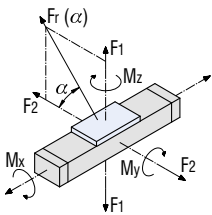

LES 5 with two WS 5/70		LES 5 with four WS 5/70	
$C_0$	5,153.30 N	$C_0$	6,606 N
$C$	2,319.41 N	$C$	3,746 N
$F_1$ stat.	4,401.33 N	$F_1$ stat.	5,642 N
$F_1$ dyn.	1,980.96 N	$F_1$ dyn.	3,198 N
$F_2$ stat.	5,153.30 N	$F_2$ stat.	6,606 N
$F_2$ dyn.	2,319.14 N	$F_2$ dyn.	3,746 N
$M_x$ stat.	376.59 Nm	$M_x$ stat.	423.15 Nm
$M_y$ stat.	164.31 Nm	$M_y$ stat.	366.73 Nm
$M_z$ stat.	192.39 Nm	$M_z$ stat.	429.39 Nm
$M_x$ dyn.	169.49 Nm	$M_x$ dyn.	239.85 Nm
$M_y$ dyn.	73.95 Nm	$M_y$ dyn.	207.87 Nm
$M_z$ dyn.	86.59 Nm	$M_z$ dyn.	243.49 Nm

### Permissible spindle speeds

LES 4 / 5 / 6	Spindle pitch p [mm]	max. permissible spindle speed n [rpm]					max. permissible feed speed v permissible [mm/s]				
		2.5	4	5	10	20	2.5	4	5	10	20
490	4000	167	267	333	667	1333					
990	3000	125	200	250	500	1000					
1390	1500	63	100	125	250	500					
1490 *	3000	125	200	250	500	500					
1990 *	1650	69	110	138	275	550					
2490 *	1050	44	70	88	175	350					
2990 *	750	31	50	63	125	250					

\* with spindle support

### Dimensioned drawing

Process travel  
 at 2xWS 5/70 = L1 -150 mm  
 at 4xWS 5/70 = L1 -280 mm

motor module dimensions see pages B-47  
 external limit switches see pages B-61

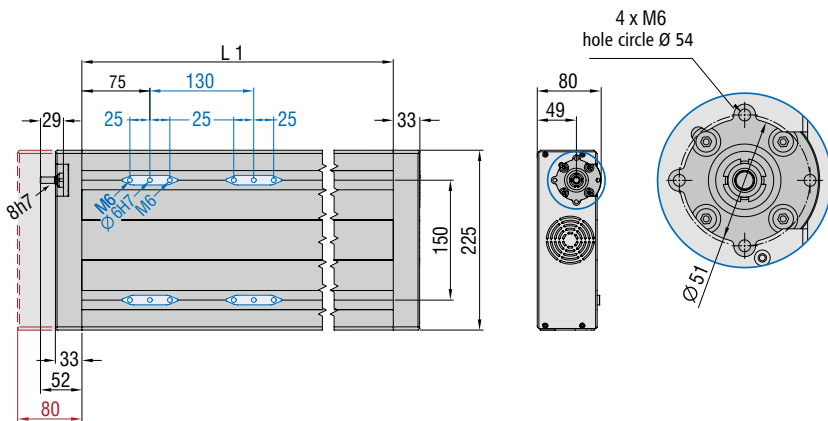

### Dimensioned drawing

Aluminium profile

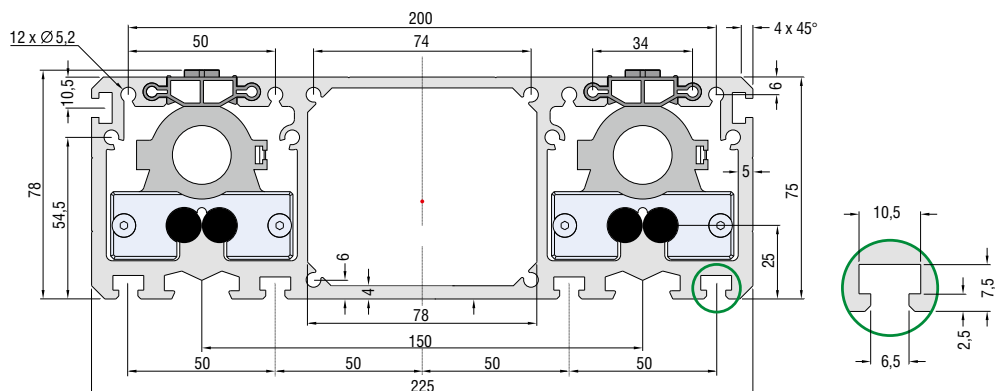

calculations on the „theoretical critical speed“ and the „drive size“ can be found at [www.isel.com/en/products/mechanics/linear-units/linear-units-les5](http://www.isel.com/en/products/mechanics/linear-units/linear-units-les5)

# Combination examples LES ... with cable drag chain 9

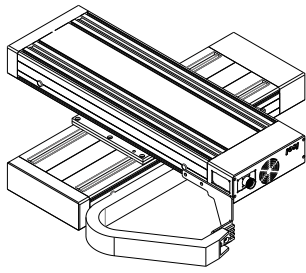

## Crossbench

2 x LES 5  
 PS 4 with VP 2  
 Fixing cable drag chain 9  
 Slide on slide assembly

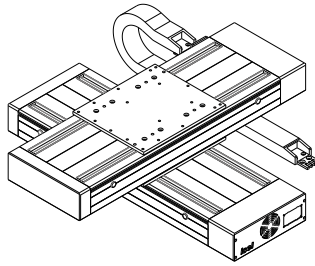

## Crossbench

2 x LES 5  
 PS 4 with VP 2  
 Fixing cable drag chain 9  
 Profile on slide assembly

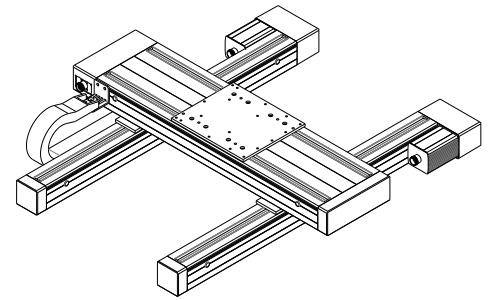

## 2-axis H-design

2 x LES 4, LES 5, 2 x PS 2, PS 4,  
 Fixing cable drag chain 9  
 Gantry mode

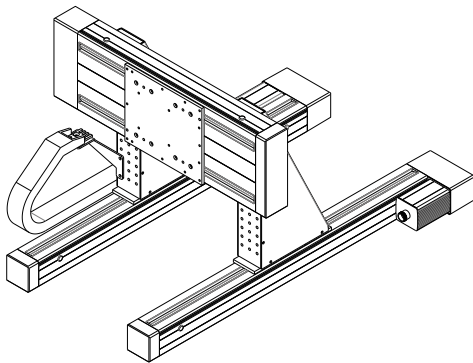

## 2-axis flatbed configuration

2 x LES 4, LES 5, 2 x PS 2  
 2 x WV 2, PS 4, Fixing cable drag chain 9  
 Gantry mode

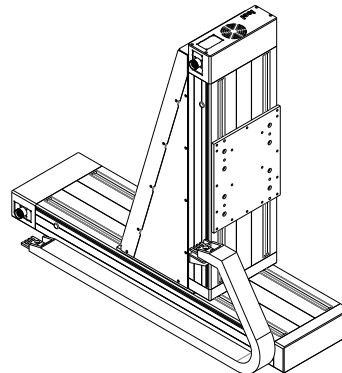

## 2-axis lifting configuration

2 x LES 5, 2 x PS 4, WV 6,  
 Fixing cable drag chain 9

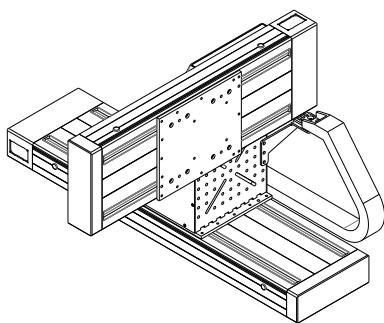

## 2-axis boom configuration

2 x LES 5  
 2 x PS 4  
 WV 3  
 Fixing cable drag chain 9

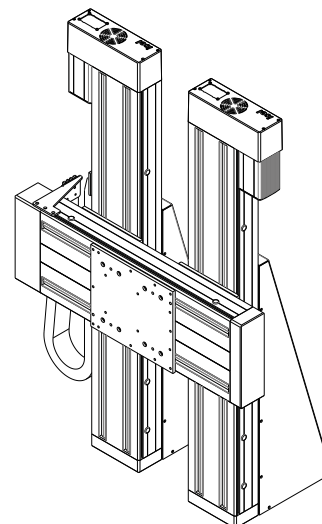

## 2-axis H-design

LES 5, 2 x LES 6, 2 x WV 7,  
 2 x PS 12, PS 4,  
 Fixing cable drag chain 9,  
 Gantry mode

# Combination examples LES ... with cable drag chain 9

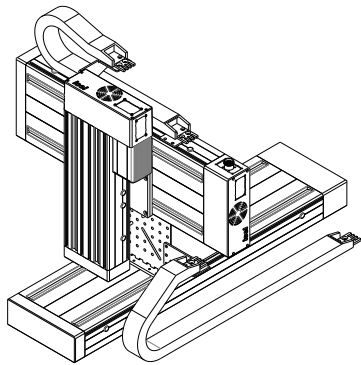

## 3-axis boom configuration

2 x LES 5, LES 6, WV 3, PS 4, PS 7, Fixing cable drag chain 9

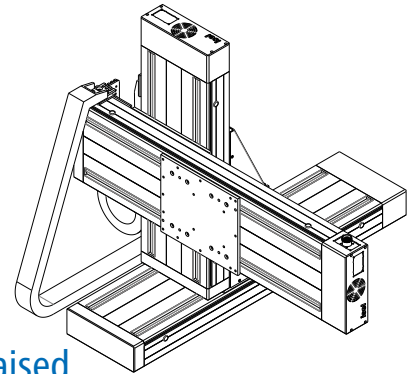

## 3-axis raised configuration

3 x LES 5, WV 3, 2 x PS 4, VP 2, Fixing cable drag chain 9

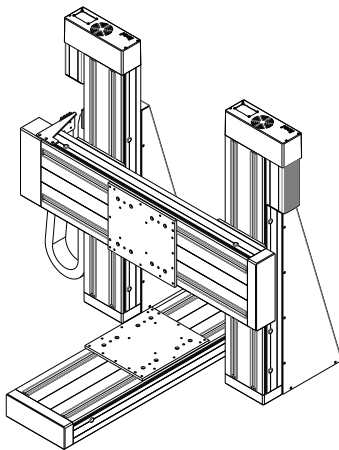

## 3-axis portal configuration

2 x LES 5, 2 x LES 6, 2 x WV 7, 2 x PS 4, 2 x PS 12, Gantry mode, Fixing cable drag chain 9

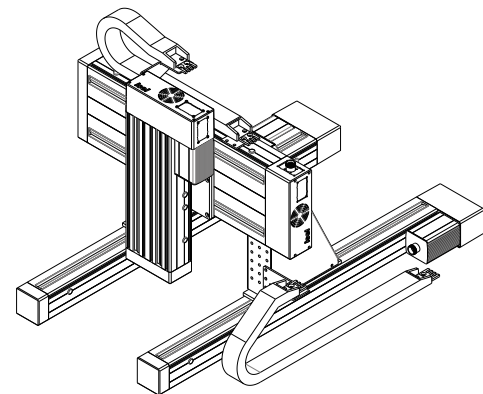

## 3-axis flatbed configuration

2 x LES 4, LES 5, LES 6, 2 x PS 2, 2 x WV 2, PS 4, PS 7, Fixing cable drag chain 9, Gantry mode

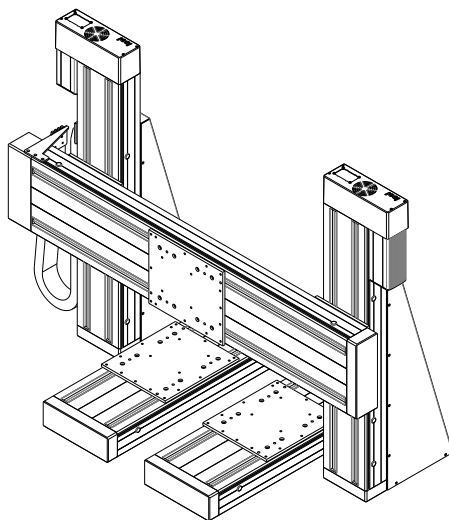

## 4-axis portal configuration

3 x LES 5, 2 x LES 6, 2 x WV 7, 3 x PS 4, 2 x PS 12, Fixing cable drag chain 9

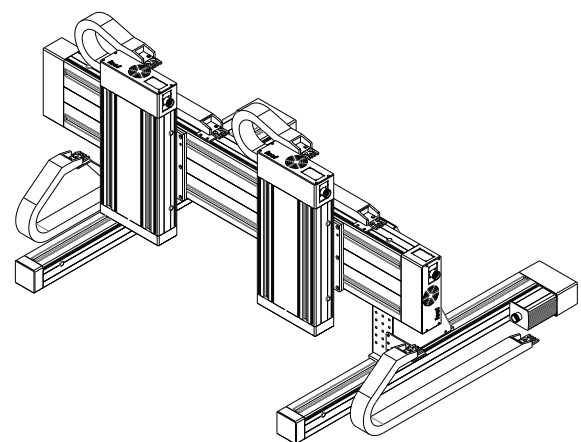

## 5-axis flatbed configuration

2 x LES 5 (Z-axis), LES 5 (2 spindle drives), 2 x LES 4, 2 x PS 2, 2 x WV 2, 2 x PS 4 with VP 2, Fixing cable drag chain 9

# Motor modules

## Ordering overview

LES 4/5/6 direct drives	Part no.	Part no.   with brake	Single axis controller	Multiple axis controller
Stepper motor MS 135	396055 0060	-	IT 116 Flash	iMC-P / iMC-S8
Stepper motor MS 200 HT-2	396058 0060	396058 0260	IT 116 Flash	iMC-P / iMC-S8
EC servomotor EC 60S	396415 0060	396415 0260	MC 1-20	iCU-EC / iPU-EC
EC servomotor EC 60SD 200W	396420 0060	396420 0260	MC 1-20	iCU-EC / iPU-EC
EC servomotor EC 60L 48V	396423 0060	396423 0260	MC 1-20	iCU-EC / iPU-EC
EC servomotor EC 60L 310V	396423 0070	396423 0270	MC 1-40	iCU-EC / iPU-EC
EC servomotor EC 86S	396444 0070	-	MC 1-40	Switching cabinet
EC servomotor EC 86L	396466 0070	-	MC 1-40	Switching cabinet
EC servomotor EC 86XL	396488 0070	-	MC 1-40	Switching cabinet
Stepper motor MS 300 HT-2	396082 0060	396082 0260	iMC-S8	iMC-S8
Stepper motor MS 600 HT	396085 0060	-	iMC-S8	iMC-S8
Stepper motor MS 900 HT	396088 0060	-	iMC-S8	iMC-S8
LES 5 integrated	Part no.	Part no.   with brake	Single axis controller	Multiple axis controller
Stepper motor MS 200 HT-2	396058 1060	396058 1260	IT 116 Flash	iMC-P / iMC-S8
EC servomotor EC 60S	396415 1060	396415 1260	MC 1-20	iCU-EC / iPU-EC
EC servomotor EC 60SD 200W	396420 1060	396420 1260	MC 1-20	iCU-EC / iPU-EC
EC servomotor EC 60L 48V	396423 1060	-	MC 1-20	iCU-EC / iPU-EC
EC servomotor EC 60L 310V	396423 1070	396423 1270	MC 1-40	Switching cabinet
LES 4/LES 6 side mounting	Part no.	Part no.   with brake	Single axis controller	Multiple axis controller
Stepper motor MS 200 HT-2	396058 2060	396058 2260	IT 116 Flash	iMC-P
EC servomotor EC 60S	396415 2060	396415 2260	MC 1-20	iCU-EC
EC servomotor EC 60SD 200W	396420 2060	396420 2260	MC 1-20	iCU-EC
EC servomotor EC 60L 48V	396423 2060	-	MC 1-20	iCU-EC
EC servomotor EC 60L 310V	396423 2070	396423 2270	MC 1-40	iCU-EC

# Motor modules

## Dimensioned drawing

### Motor module 1

Part no.	Motor module	Length L
396055 0060	MS 135 without brake	105 mm
396058 0360	MS 200 HT-2 with brake	155 mm
396058 0060	MS 200 HT-2 without brake	155 mm

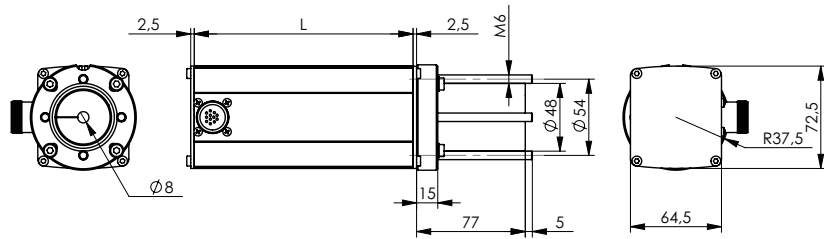

## Dimensioned drawing

### EC 60

Part no.	Motor module	Length L
396415 0260	EC 60S with brake	99 mm
396415 0060	EC 60S without brake	99 mm
396423 0060	EC 60L 48V	120 mm
396423 0070	EC 60L 310V	120 mm

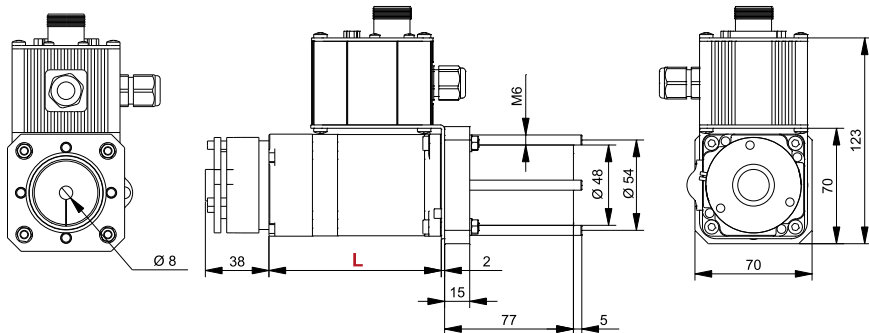

## Dimensioned drawing

### Motor module 2

Part no.	Motor module	Length L
396466 0070	EC 86L	151 mm
396444 0070	EC 86S	126 mm
396085 0060	MS 600HT	96 mm
396088 0060	MS 900 HT	126 mm

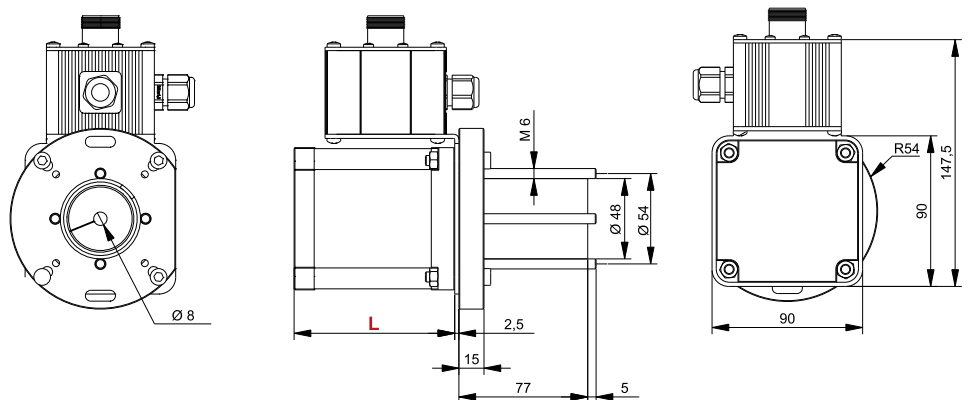

## Dimensioned drawing

### Motor module / side mounting

Part no.	LES4/LES6 side mounting	Length L	width B LES4	width B LES6
396058 2060	MS 200 HT	107 mm	150 mm	225 mm
396058 2260	MS 200 HT with brake	157 mm	150 mm	225 mm
396415 2060	EC 60S	277 mm	160 mm	235 mm
396415 2260	EC 60S with brake	277 mm	160 mm	235 mm
396420 2060	EC 60SD 200W	277 mm	160 mm	235 mm
396420 2260	EC 60SD 200W with brake	277 mm	160 mm	235 mm
396423 2060	EC 60L 48V	277 mm	160 mm	235 mm
396423 2070	EC 60L 310V	277 mm	160 mm	235 mm
396423 2270	EC 60L 310V with brake	277 mm	160 mm	235 mm

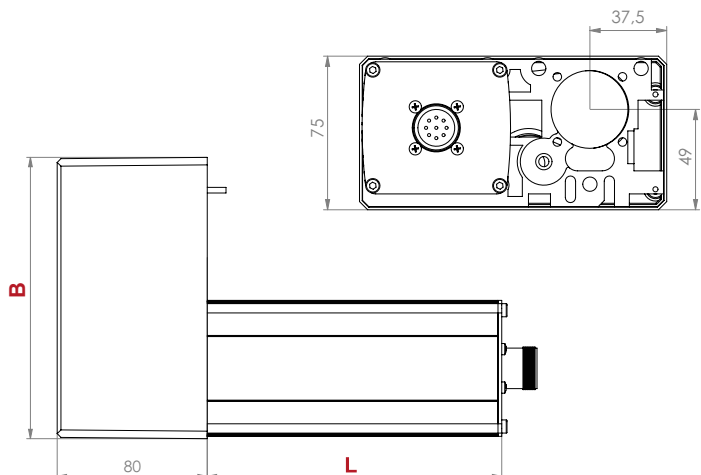

# Clutch housing

## Drive element accessories

### Connection options

Direct drive preparation

Connecting options <i>Direct drive</i>	LES 4	LES 6	LES 5	Angular gear fixing 0°	Angular gear fixing 90°
MS 200 HT-2 EC 60	Connection via coupling casing 1 <i>short sleeve</i> with adequate shaft coupling			Coupling casing 1 <i>long sleeve</i>	
MS 600 HT MS 900 HT EC 86	Connection via coupling casing 2 <i>short sleeve</i> with adequate shaft coupling			Coupling casing 2 <i>long sleeve</i>	
Angular gear fixing 0°	split coupling casing <i>short sleeve</i> with adequate shaft coupling			Connection via transmission shaft set	
Angular gear fixing 90°	split coupling casing <i>short sleeve</i> with adequate shaft coupling				

### Ordering overview

Clutch housing

Clutch housing 1

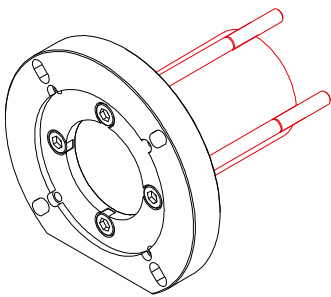

short sleeve  
Part no.: 218 100 0001

long sleeve  
Part no.: 218 100 0002

Clutch housing 2

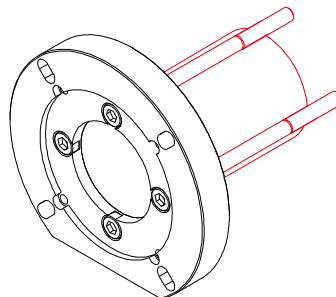

short sleeve  
Part no.: 218 100 1001

long sleeve  
Part no.: 218 100 1002

Split clutch housing

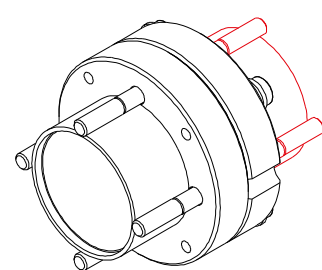

short sleeve  
Part no.: 218 100 2001

long sleeve  
Part no.: 218 100 2002

### Clutches



coupling	Item no.:	d <sub>1</sub>	d <sub>2</sub>
20/30	218 001 5060	5,0	6,0
	218 001 9999	from 4 to 7 mm	
30/40	218 002 6380	6,35	8,0
	218 002 8080	8,0	8,0
	218 002 9999	from 6 to 13 mm	
40/60	218 003 9580	9,52	8,0
	218 003 9999	from 8 to 18 mm	

# Clutch housing

## Drive element accessories

### Dimensioned drawing

#### Coupling casing 1

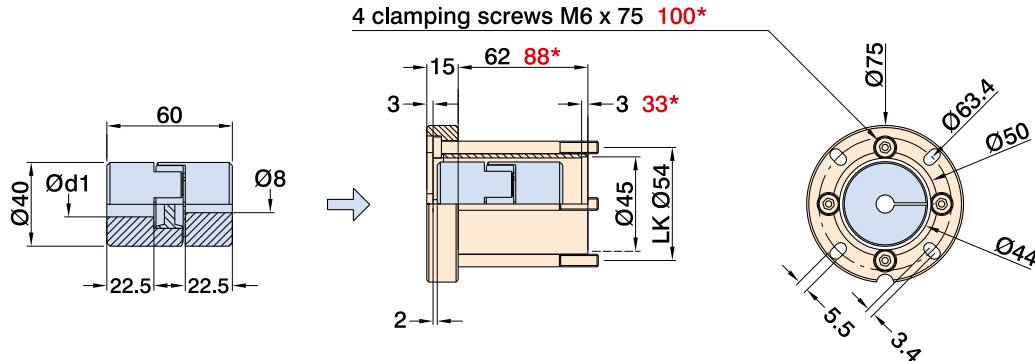

*\*) Measures refer to the dimensions with long sleeves*  
*d1 = engine shaft diameter 6.35/8/9 mm*  
*Suitable shaft coupling WK 40/60 on page 2-68 (not included in scope of delivery)*

### Dimensioned drawing

#### Coupling casing 2

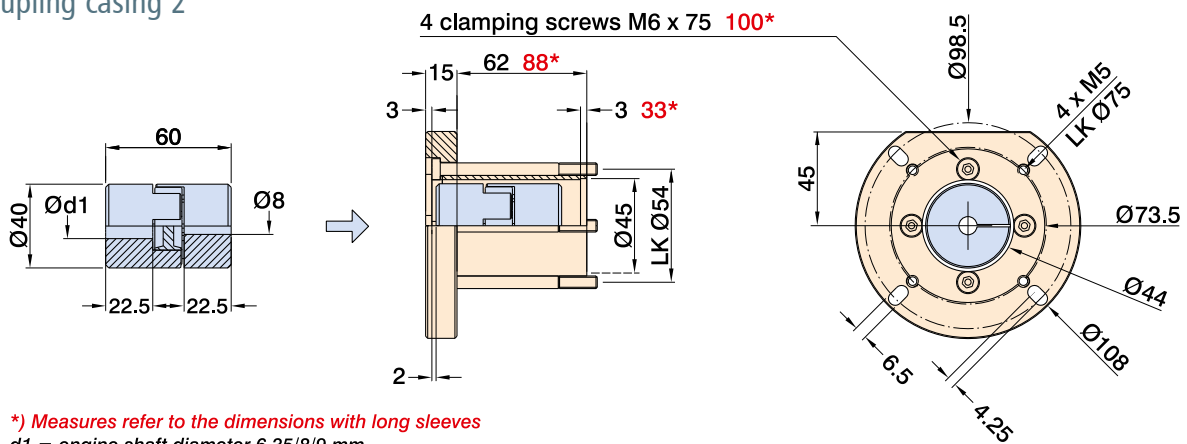

*\*) Measures refer to the dimensions with long sleeves*  
*d1 = engine shaft diameter 6.35/8/9 mm*  
*Suitable shaft coupling WK 40/60 on page 2-68 (not included in scope of delivery)*

### Dimensioned drawing

#### Split coupling casing

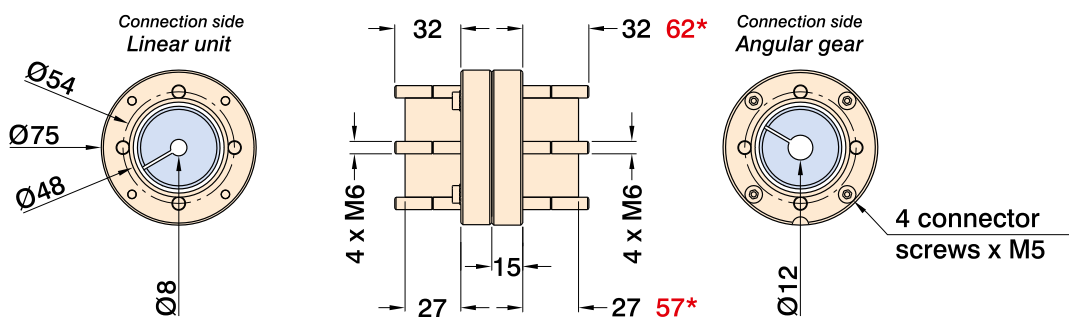

*\*) Measures refer to the dimensions with long sleeves*  
*Suitable shaft coupling WK 40/60 on page 2-68 (not included in scope of delivery)*

# Motor pin assignments

## Pin assignment for stepper motors

Motor connection

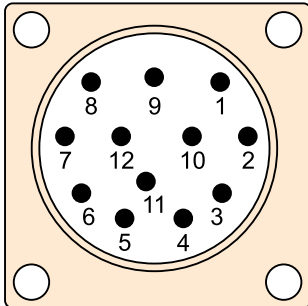

View of pin insert at the insertion side

M23 12-pin Pin	
1	Motor phase 1A
2	Motor phase 1B
3	Motor phase 2A
4	Motor phase 2B
5	+24V switch
6	+24V brake
7	GND switch
8	GND brake
9	Limit switch 1
10	Limit switch 2
11	---
12	---
Housing - cable shield	

Motor connection

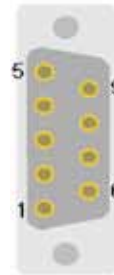

View of pin insert on the socket side

Sub-D 9-pin Pin	
1	Motor phase 1A
2	Motor phase 1B
3	Motor phase 2A
4	Motor phase 2B
5	+24V switch
6	+24V brake
7	Limit switch 2
8	GND brake
9	Limit switch 1
Housing - cable shield	

## Pin assignment for brushless EC servo motors (BLDC) 48V

Motor connection

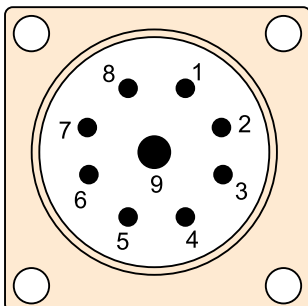

View of pin insert on the socket side

M23 9-pol. (8+1) pin	
1	Motor phase U
2	Motor phase V
3	Motor phase W
4	---
5	+24V brake
6	GND brake
7	---
8	---
9	Earthing lead
Housing - cable shield	

Encoder connection



View of pin insert on the socket side

Sub-D 15-pin Pin	
1	Hall signal A
2	+5V encoder/Hall
3	Encoder track/Z
4	Encoder track/B
5	Encoder track/A
6	+24V switch
7	Limit switch 1
8	GND switch
9	Hall signal B
10	GND encoder
11	Encoder track Z
12	Encoder track B
13	Encoder track A
14	Hall signal C
15	Limit switch 2
Housing - cable shield	

## Pin assignment for brushless EC servomotors (BLDC) 310V

Motor connection

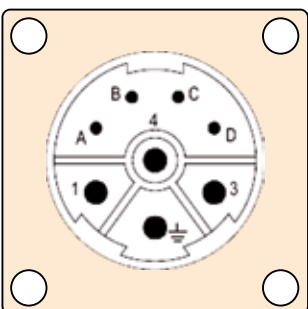

View of pin insert at the insertion side

M23 8-pol. (4+3+1) pin	
1	Motor phase U
PE	Earthing lead
3	Motor phase W
4	Motor phase V
A	+24V brake
B	GND brake
C	Temp +
D	Temp -
Housing - cable shield	

Encoder connection

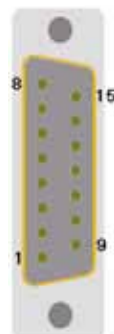

View of pin insert at the insertion side

Sub-D 15-pin Pin	
1	Hall signal A
2	+5V encoder/Hall
3	Encoder track/Z
4	Encoder track/B
5	Encoder track/A
6	+24V switch
7	Limit switch 2
8	GND switch
9	Hall signal B
10	GND encoder
11	Encoder track Z
12	Encoder track B
13	Encoder track A
14	Hall signal C
15	Limit switch 2
Housing - cable shield	



# Motor leads

## Overview of motor leads for stepper, DC servo and EC motors\*

Part number	Description
392750 0500	5-metre stepper motor lead M23 12-pin plug - socket 1:1
392755 0500	5-metre stepper motor lead D-sub 9-pin plug - M23 12-pin socket
392781 0500	5-metre stepper motor lead D-sub 9-pin plug - socket 1:1
392759 0500	5-metre DC/EC servo motor lead M23 9-pin (8 + PE) plug - socket 1:1
392760 0500	5-metre DC/EC servo motor lead M23 9-pin (8+PE) socket - wire end ferrules
392740 0500	5-metre encoder lead D-sub 15-pin plug - socket 1:1
392325 0500	5-metre encoder lead M23 17-pin socket - D-sub 15-pin plug
392305 0500	3-metre EC/AC servo motor lead M23 310V (4+3+PE) socket - wire end ferrules
392307 0500	5-metre EC servo motor lead M23 (4+3+PE) plug - socket 1:1

All listed motor and encoder leads are fit for use with tow chains.

\* Different lengths available on request!

# Installation kit with angular transmission

# Drive element accessories

## Installation alternatives

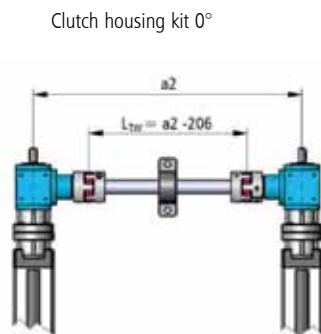
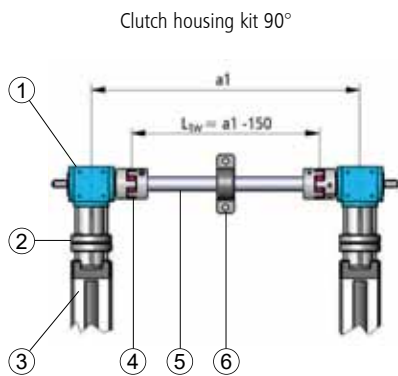

- ① Angular gear
- ② Split coupling casing with shaft coupling WK 40/60
- ③ LES 4, LES 6 or LES 5 (preparation for direct drive)
- ④ Coupling for transmission shaft Ø 25
- ⑤ Transmission shaft Ø 25
- ⑥ Pedestal bearing - recommendable from : transmission shaft length of 1,500 mm up

## Dimensioned drawing

### Angular transmission

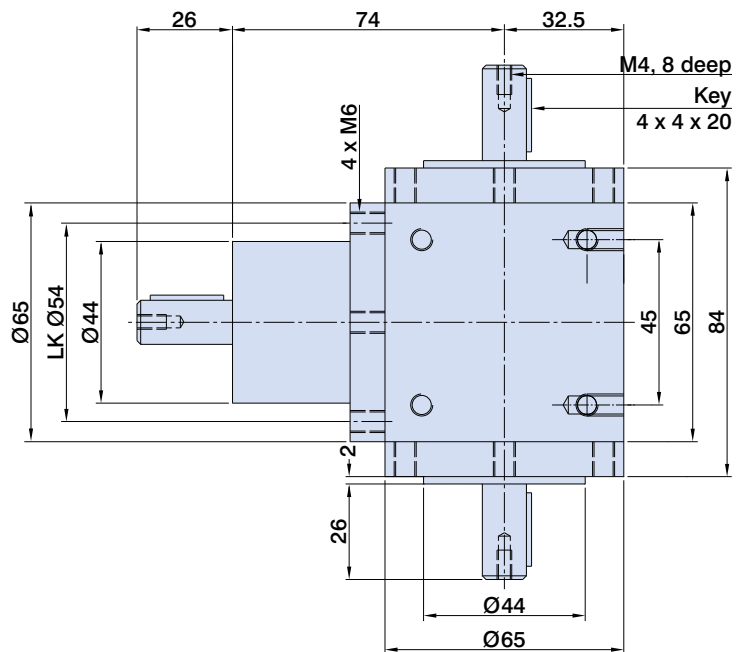
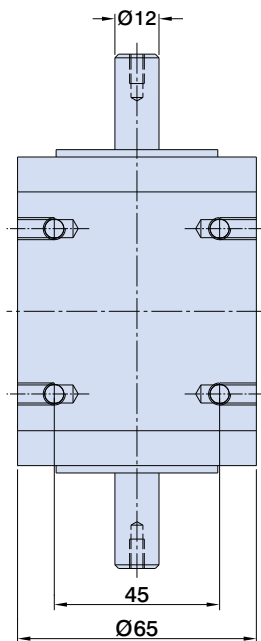

## Ordering overview

### Installation kit with angular transmission

for H-design on LES 4/LES 6/LES 5,  
0° mounting  
Scope of delivery: 2 x(1), 2 x(2), 2 x(4)  
Part no.: **216150 0001**

for H-design on LES 4/LES 6/LES 5,  
90° mounting  
Scope of delivery: 2 x(1), 2 x(2), 2 x(4)  
Part no.: **216150 0002**

### Transmission shaft

Hollow shaft Ø 25 mm × 4 mm, blank  
1000 mm  
Part no.: **219001 0125**

Hollow shaft Ø 25 mm × 4 mm, blank  
2000 mm  
Part no.: **219001 0225**

### Coupling/stationary bearing

Coupling for transmission shaft  
12 to 25 mm adaptor, VE 2 units  
Part no.: **218050 0002**

Stationary bearing for transmission shaft  
VE 1 unit  
Part no.: **896202 5562**

For matching direct drive modules LES 4/5/6 see table on page **B-46**

# Installation kit with angular transmission

## Drive element accessories

### Dimensioned drawing and technical specification

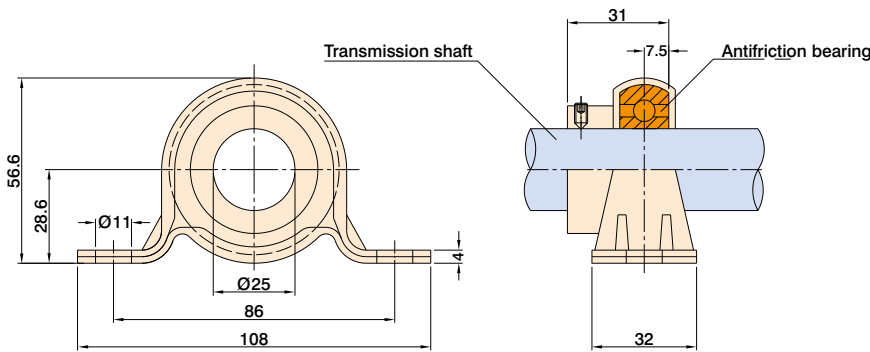

**Pedestal bearing** - to avoid vibrations/to support the transmission shaft (recommendable from a transmission shaft length of 1,500 mm up)

<b>Transmissible torque</b>	18 Nm
<b>Weight of coupling</b>	0,205 kg
<b>Weight of shaft</b>	0,540 kg/m
<b>Moment of inertia of both couplings</b>	1,340 10 <sup>-4</sup> kgm <sup>2</sup>
<b>Moment of inertia of shaft</b>	8,171 10 <sup>-6</sup> kgm <sup>2</sup> /100 mm

### Dimensioned drawing - coupling

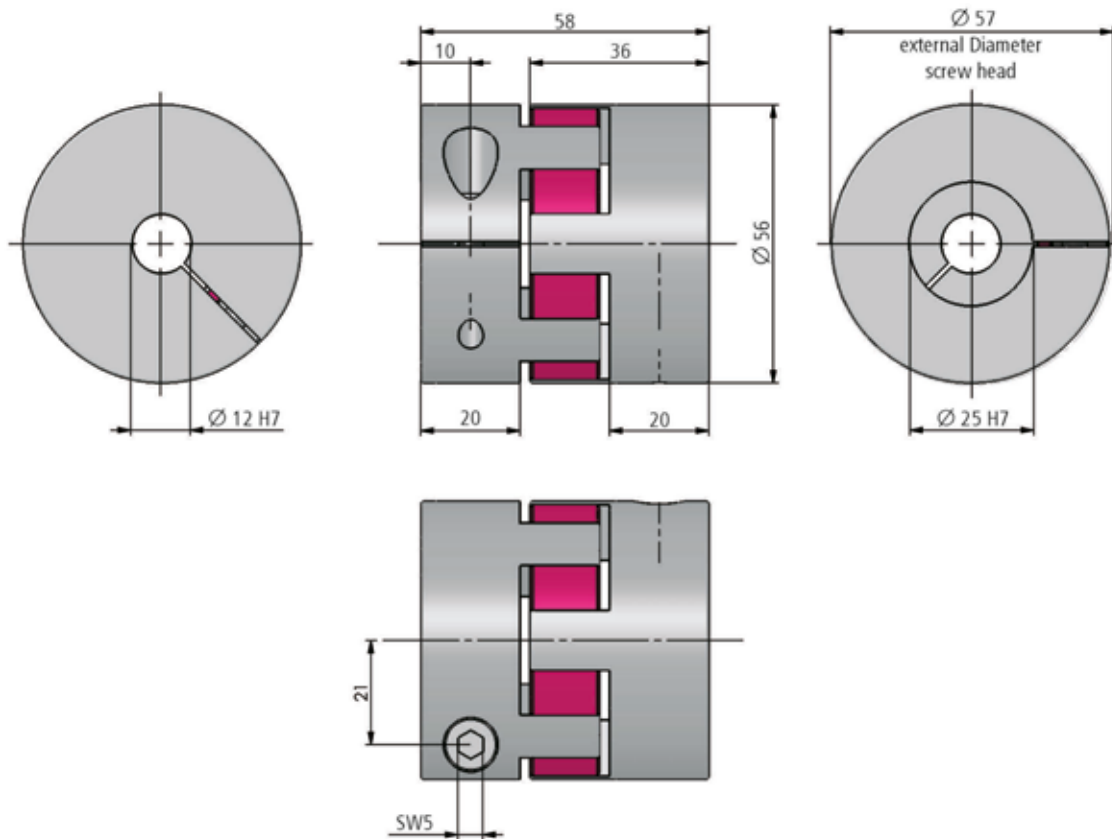

Part no. **218050 0002**

# Slide/crossbench plates

# Connectors

## Hole diagram, slide plate PS 1

L 125 x W 70 x H 7.7 mm

Mounting on:  
LES 4 with 1 x WS 5/70

Part no.: **277001**

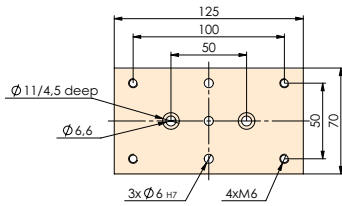

## Hole diagram, slide plate PS 2

L 255 x W 70 x H 7.7 mm

Mounting on:  
LES 4 with 2 x WS 5/70

Fixing option for:  
Angle bracket WV 2 / WV 5

Part no.: **277002**

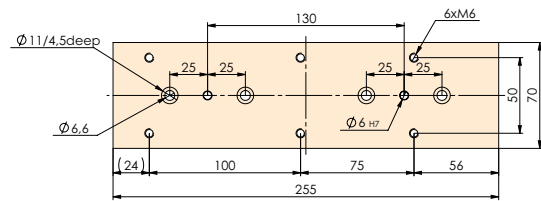

## Hole diagram, slide plate PS 3

L 220 x W 125 x H 7.5 mm

Mounting on:  
LES 5 with 2 x WS 5/70

Part no.: **277003**

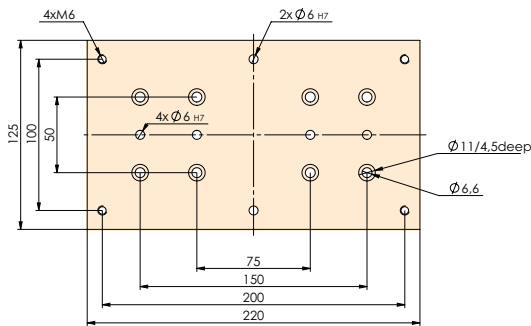

## Hole diagram, slide plate PS 4

L 225 x W 220 x H 7.5 mm

Mounting on: LES 5 with 4 x WS 5/70  
Mounting on crossbench: LES 5 with LES 5 (in conjunction with VP 2)  
Fixing option for: Angle bracket WV 3 / WV 6

Part no.: **277004**

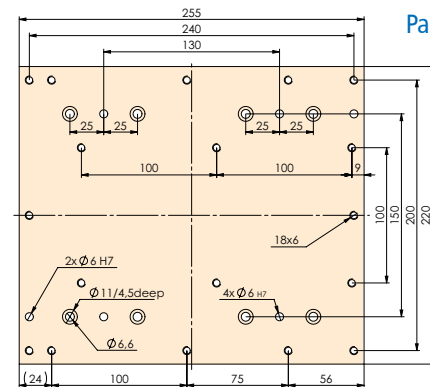

## Hole diagram, slide plate PS 6

L 220 x W 125 x H 7.5 mm

Mounting on: LES 4 with 2 x WS 5/70  
Mounting on crossbench: LES 4 with LES 5 (in conjunction with PS 3).  
Fixing option for: LES 4/LES 5

Part no.: **277011**

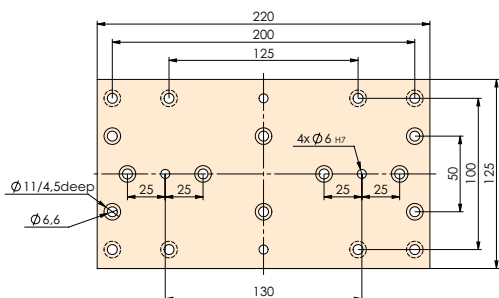

## Hole diagram, slide plate PS 7

L 255 x W 220 x H 7.5 mm

Mounting on: LES 6 with 4 x WS 5/70  
Mounting on crossbench: LES 6 with LES 5 (in conjunction with PS 4)

Part no.: **277016**

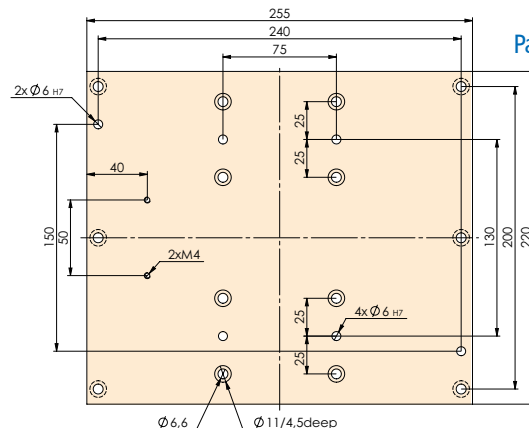

## Slide/crossbench plates

## Connectors

## Hole diagram, slide plate PS 8

L 125 × W 145 × H 7.5 mm

Mounting on:

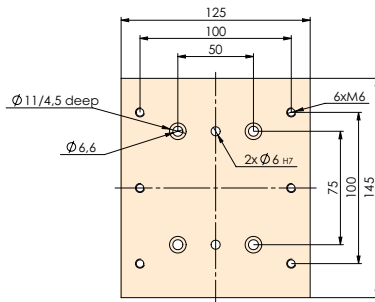
LES 6 with 2 × WS 5/70 **Part no.: 277017**

## Hole diagram, slide plate PS 9

L 250 × W 145 × H 7.5 mm

Mounting on: LES 6 with 4 × WS 5/70

Fixing option for: Angle bracket WV 7

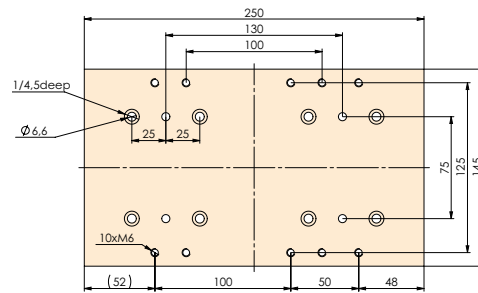
**Part no.: 277018**

## Hole diagram, slide plate PS 10

L 210 × W 215 × H 7.5 mm

Mounting on: LES 6 with 4 × WS 5/70

Mounting on crossbench: LES 6 with LES 6 (in conjunction with PS 11)

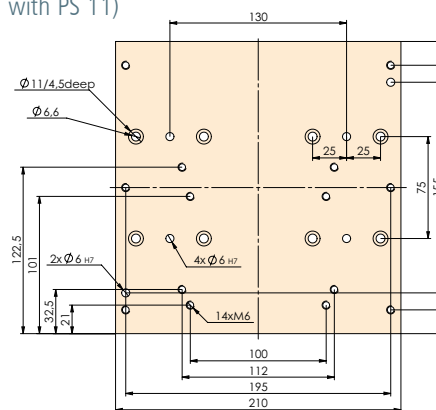
**Part no.: 277019**

## Hole diagram, slide plate PS 11

L 210 × W 215 × H 7.5 mm

Mounting on: LES 6 with 4 × WS 5/70

Mounting on crossbench: LES6 with LES4 (in conjunction with PS10) Fixing option for: LES 6

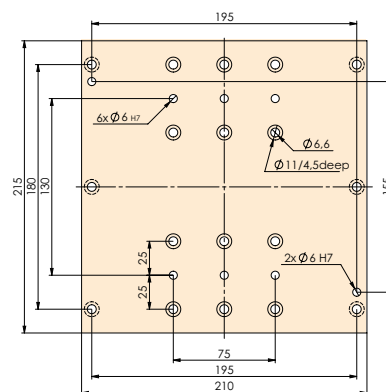
**Part no.: 277020**

## Hole diagram, slide plate PS 12

L 220 × W 180 × H 7.5 mm

Mounting on: LES 6 with 4 × WS 5/70

Fixing option for: LES 5

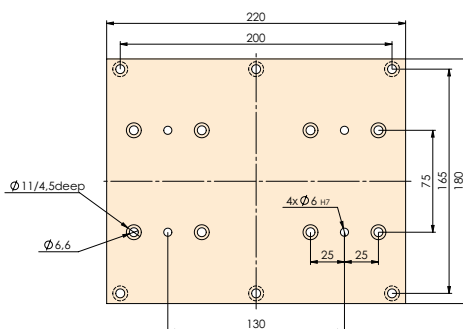
**Part no.: 277021**

## Hole diagram, connection plate VP 2

L 255 × W 220 × H 7.5 mm

Mounting on: LES 5 with 4 × WS 5/70

Fixing option for: LES 5

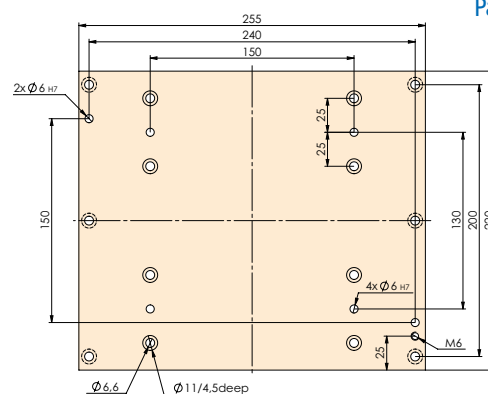
**Part no.: 277006**

# Slide/crossbench plates

# Connectors

## Hole diagram, slide plate set for crossbench LES 4

L 100 x W 100 x H 8 mm

Mounting on: LES 4  
Fixing option for: LES 4

Part no.: **277008**

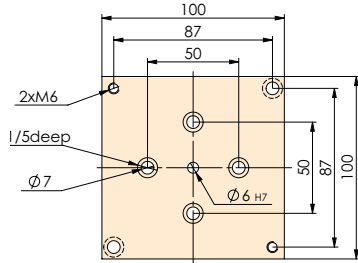

## Connecting cross 2 x LES 4

Part no.: **277007**

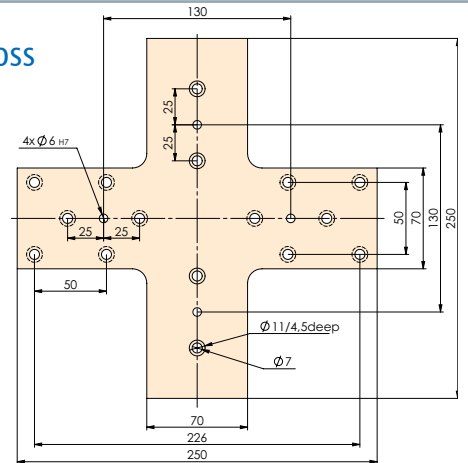

## Crossbench connection plates 1



## Crossbench connection plates 1

2 × L 255 × W 220 × H 8 mm

one set from PS 4 and VP 2,  
for right-angled connection  
two linear guides LES 5

Part no.: **277010**

## Crossbench connection plates 2



## Crossbench connection plates 2

2 × L 220 × W 125 × H 8 mm

one set from PS 3 and PS 6,  
for right-angled connection  
one linear guide LES 5 with one  
linear guide LES 4

Part no.: **277012**

## Additional combination examples



Crossbench LES 5 and LES 6  
PS 4 and PS 7



Crossbench 2 × LES 6  
PS 10 and PS 11



Crossbench LES 4 and LES 6  
PS 11 and PS 10

# T-slot slide plates

# Connectors

## Hole pattern T-slot plate PT 25 × 250 for LES 4

L 100 x W 75 x H 20 mm

Mounting on: LES 4 with 1 x WS 5/70

Part no.: **277030 0001**

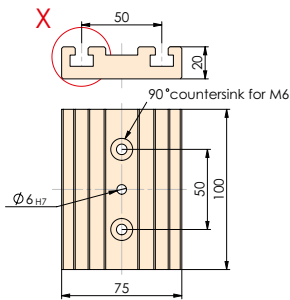

L 200 x W 75 x H 20 mm

Mounting on: LES 4 with 2 x WS 5/70

Part no.: **277030 0002**

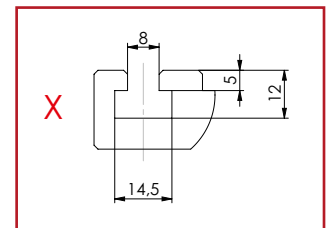
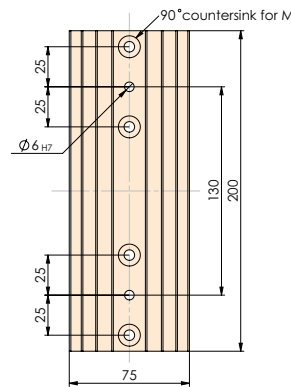

## Hole pattern T-slot plate PT 25 × 250 for LES 6

L 100 x W 125 x H 20 mm

Mounting on: LES 6 with 2 x WS 5/70

Part no.: **277030 0003**

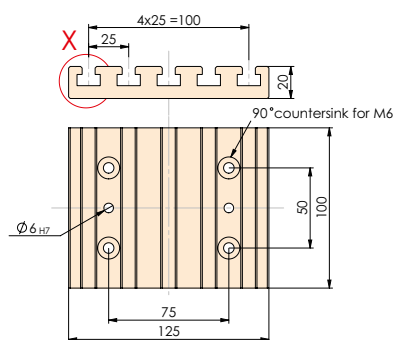

L 200 x W 125 x H 20 mm

Mounting on: LES 6 with 4 x WS 5/70

Part no.: **277030 0004**

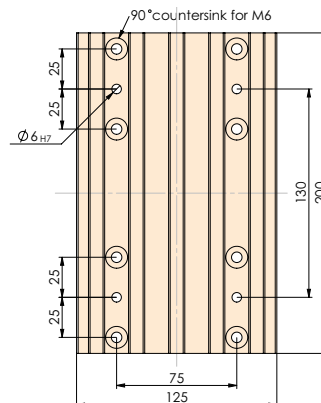

## Hole pattern T-slot plate PT 25 × 250 for LES 5

L 100 x W 250 x H 20 mm

Mounting on: LES 5 with 2 x WS 5/70

Part no.: **277030 0005**

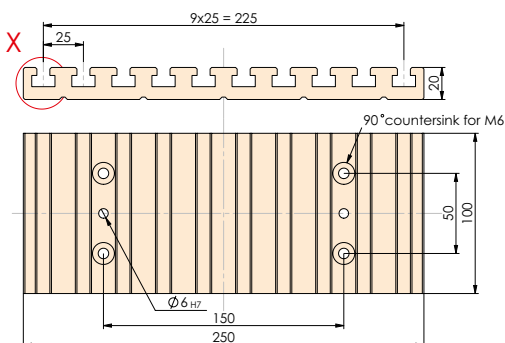

L 200 x W 250 x H 20 mm

Mounting on: LES 5 with 4 x WS 5/70

Part no.: **277030 0006**

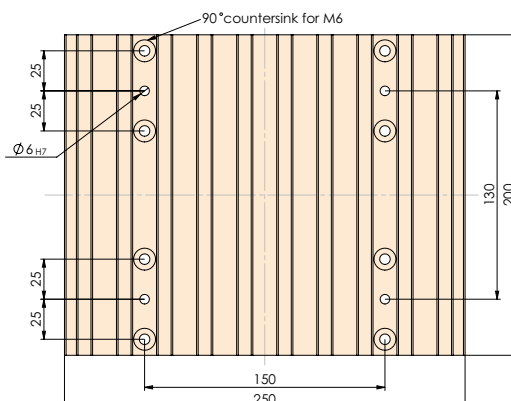

# Angle brackets

# Connectors

## Angle bracket with clamping surfaces milled flat

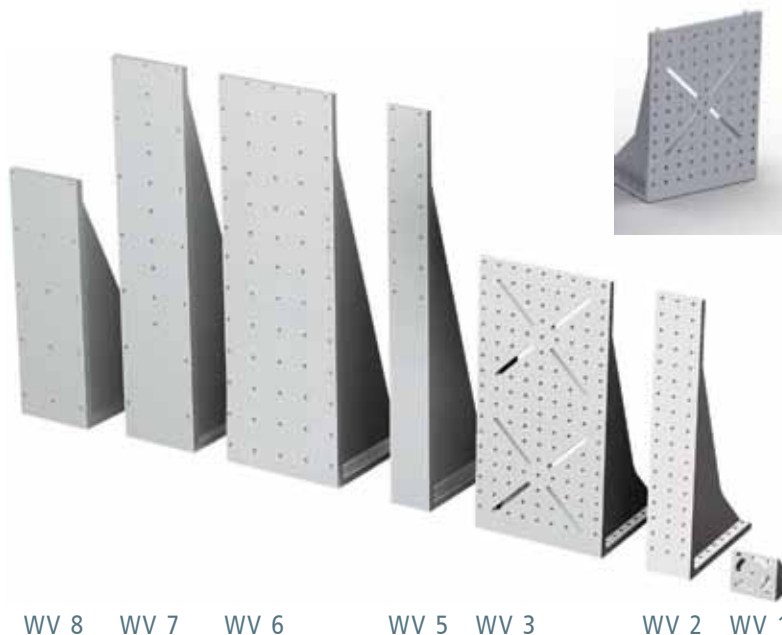

## matching cover plates

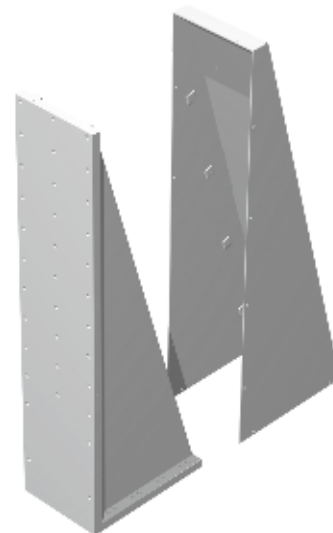

### Angle bracket WV 1

- blank
  - aluminium casting (0.2 kg)
  - L71 x W75 x H71
- Part no.: **209110 0010**

### Angle bracket WV 6

- blank
  - aluminium welded (13.3 kg)
  - L220 x W220 x H670
- Part no.: **209110 0060**

### Angle bracket WV 2

- blank
  - aluminium casting (2.6 kg)
  - L221 x W75 x H446
- Part no.: **209110 0022**

### Angle bracket WV 7

- blank
  - aluminium welded (10.8 kg)
  - L220 x W145 x H670
- Part no.: **209110 0070**

### Angle bracket WV 3

- blank
  - aluminium casting (5.8 kg)
  - L221 x W221 x H446
- Part no.: **209110 0032**

### Angle bracket WV 8

- blank
  - aluminium welded (7.4 kg)
  - L222 x W145 x H446
- Part no.: **209110 0080**

### Angle bracket WV 5

- blank
  - aluminium welded (5.26 kg)
  - L220 x W75 x H670
- Part no.: **209 110 0050**

### Angle bracket WV 19

- blank
  - aluminium welded (2.5 kg)
  - L150 x W221 x H300
- Part no.: **209110 0190**

### Cover plate for WV 2

- naturally anodised
  - aluminium sheet (0.8 kg)
- Part no.: **209110 0021**

### Cover plate for WV 3

- naturally anodised
  - aluminium sheet (1.15 kg)
- Part no.: **209110 0031**

### Cover plate for WV 5

- naturally anodised
  - aluminium sheet (1.20 kg)
- Part no.: **209 110 0051**

### Cover plate for WV 6

- naturally anodised
  - aluminium sheet (1.8 kg)
- Part no.: **209110 0061**

### Cover plate for WV 7

- naturally anodised
  - aluminium sheet (1.5 kg)
- Part no.: **209110 0071**

### Cover plate for WV 8

- naturally anodised
  - aluminium sheet (1 kg)
- Part no.: **209110 0081**



# Angle brackets

# Connectors

## Hole diagram

Angle bracket WV 1

L 71 x W 75 x H 71 mm

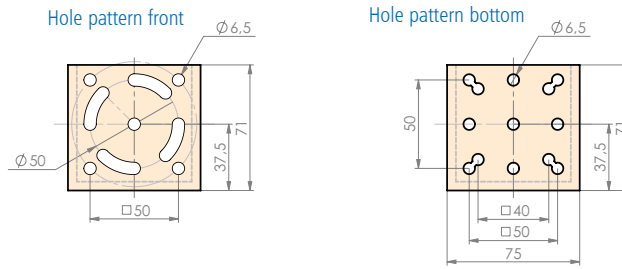

## Hole diagram

Angle bracket WV 2

L 221 x W 75 x H 446 mm

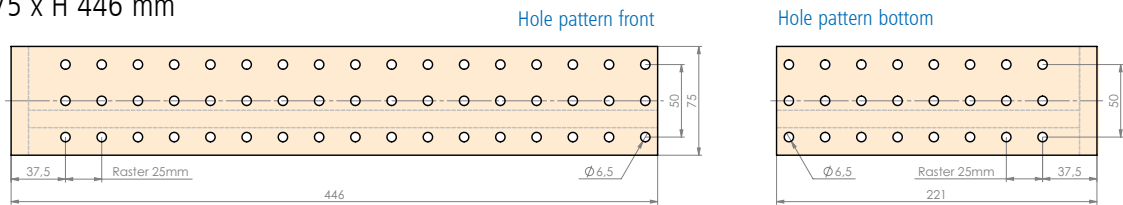

## Hole diagram

Angle bracket WV 3

L 221 x W 221 x H 446 mm

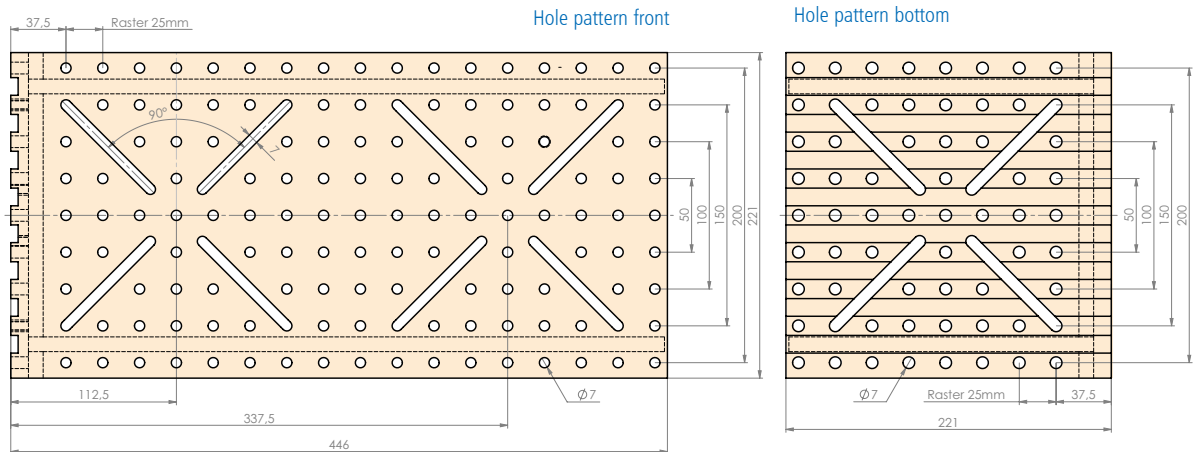

## Hole diagram

Angle bracket WV 5

L 220 x W 75 x H 670 mm

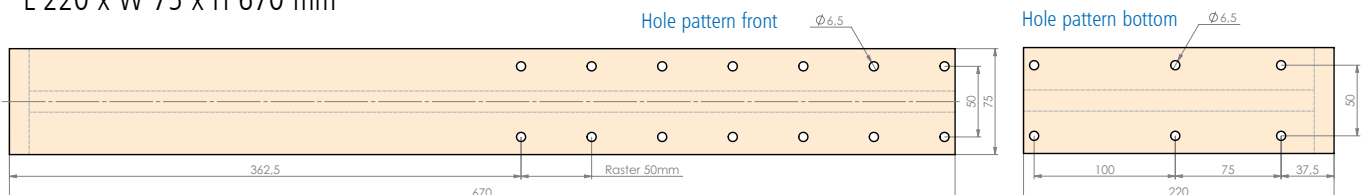

# Angle brackets

# Connectors

## Hole diagram

Angle bracket WV 6

L 220 x W 220 x H 670 mm

Hole pattern front

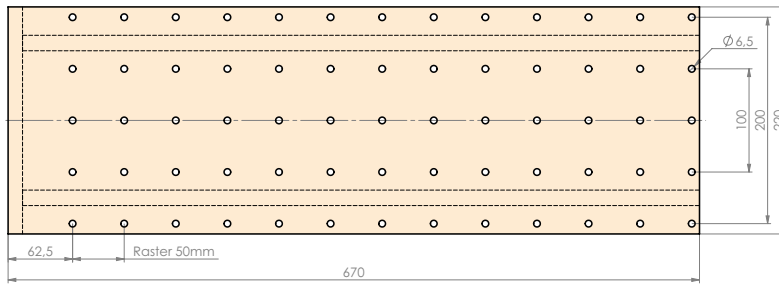

Hole pattern bottom

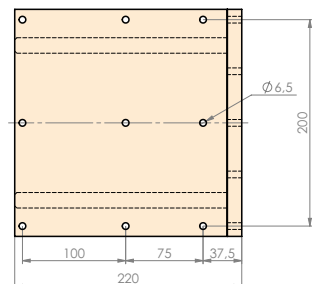

## Hole diagram

Angle bracket WV 7

L 220 x W 145 x H 670 mm

Hole pattern front

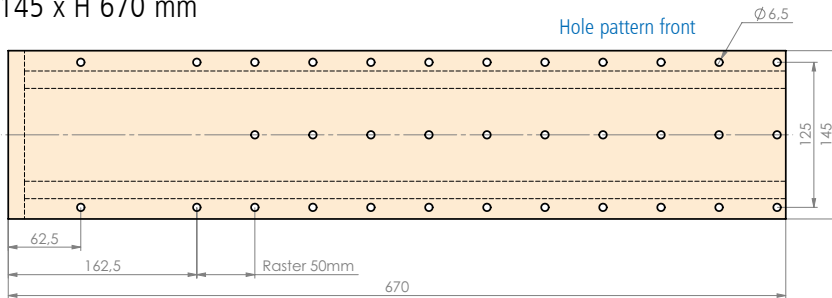

Hole pattern bottom

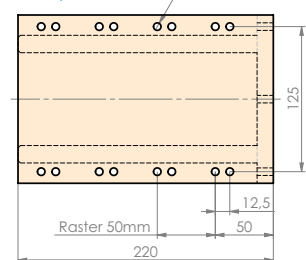

## Hole diagram

Angle bracket WV 8

L 222 x W 145 x H 446 mm

Hole pattern front

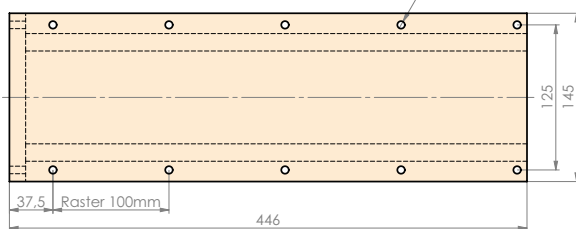

Hole pattern bottom

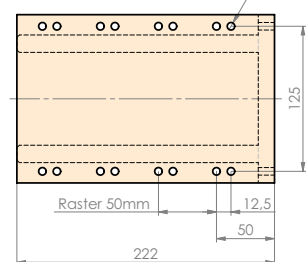

## Hole diagram

Angle bracket WV 19

L 150 x W 221 x H 300 mm

Hole pattern front

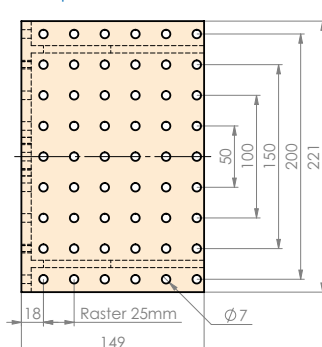

Hole pattern bottom

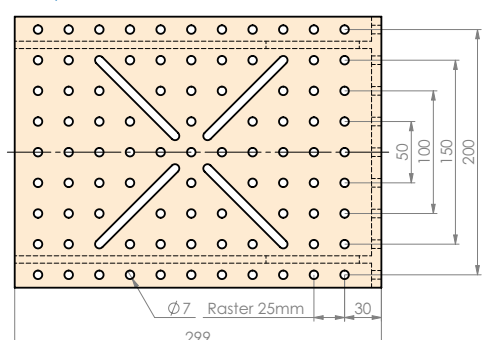

# Accessories

## Energy guidance chain



### Energy guide chain 3

- VE 1 unit at 1 m
- Part no.: **219204 1000**

### Connectors for energy chain 3

- with strain relief
- VE 1 kit
- Part no.: **219205 0002**

## Dimensioned drawing

Energy guidance chain

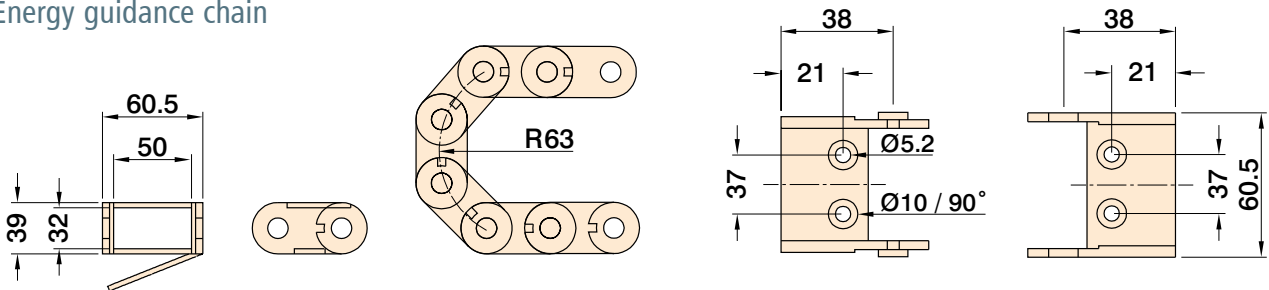

## Attachment kits

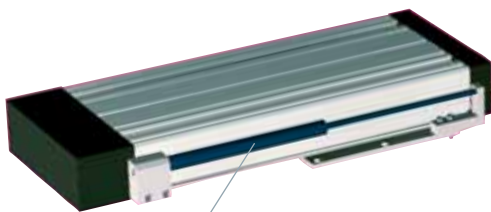

Gas pressure spring

### Gas strut attachment kit

- hub 220 mm
- nominal length 490 mm
- Part no.: **216450 0001**

### Gas strut attachment kit

- stroke 300 mm
- nominal length 690 mm
- Part no.: **216451 0001**



External limit switch

### Limit switch attachment kit for LES 4

- for external limit switches
- Part no.: **216460 0001**

### Limit switch attachment kit LES 5

- for external limit switches
- Part no.: **216460 0002**

### Limit switch attachment kit LES 6

- for external limit switches
- Part no.: **216460 0003**

### Mounting set for sealing air

- for LES4 - LES6
- Part no.: **216460 0006**

### Mounting plate, mounting-friendly screwing from above

- for LES4 Part no.: **623025 6837**
- for LES5 Part no.: **623025 6833**
- for LES6 Part no.: **675015 0362**

# Functional overview

## Linear unit with toothed belt drive

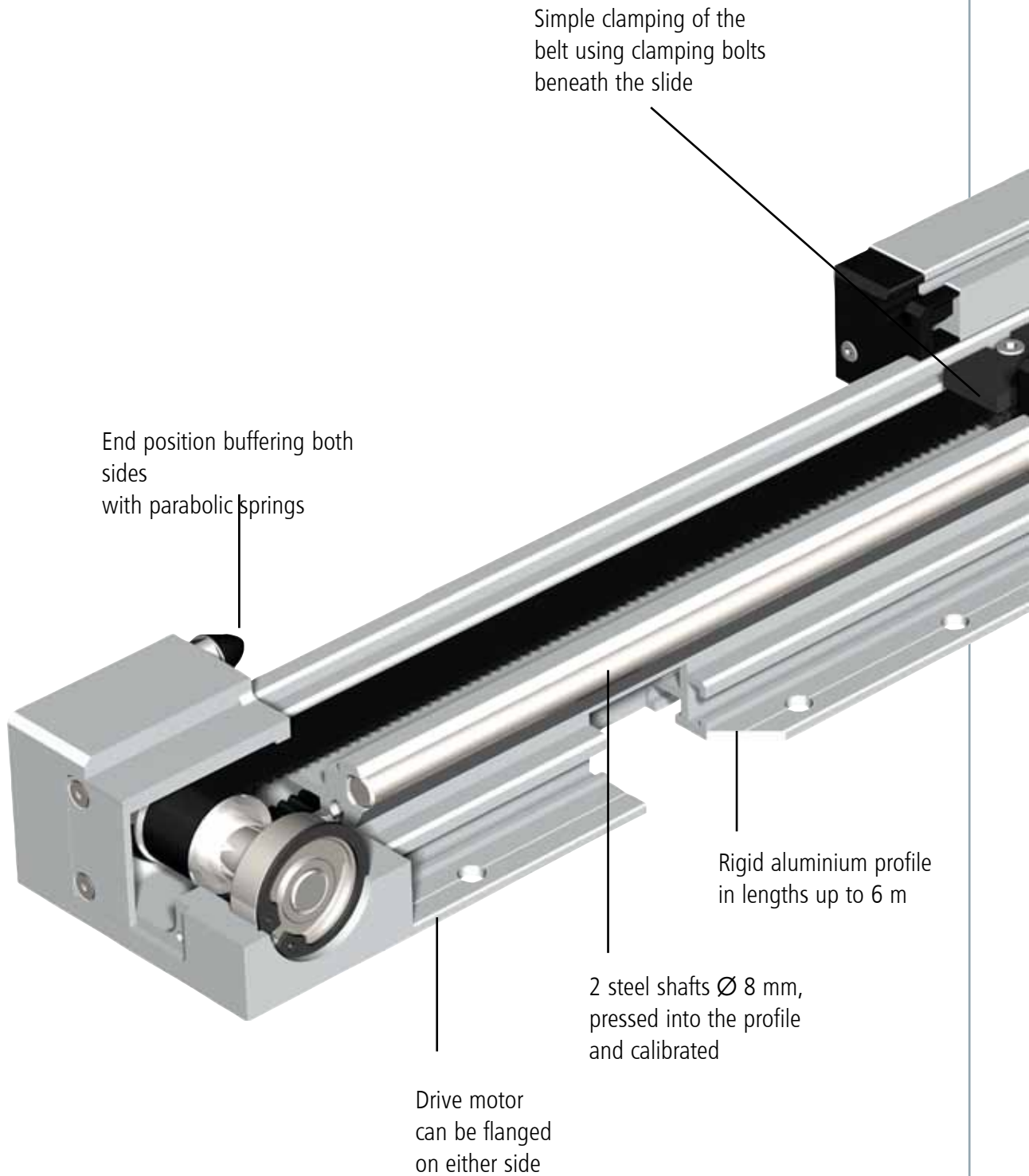

# Functional overview

## Linear unit with toothed belt drive

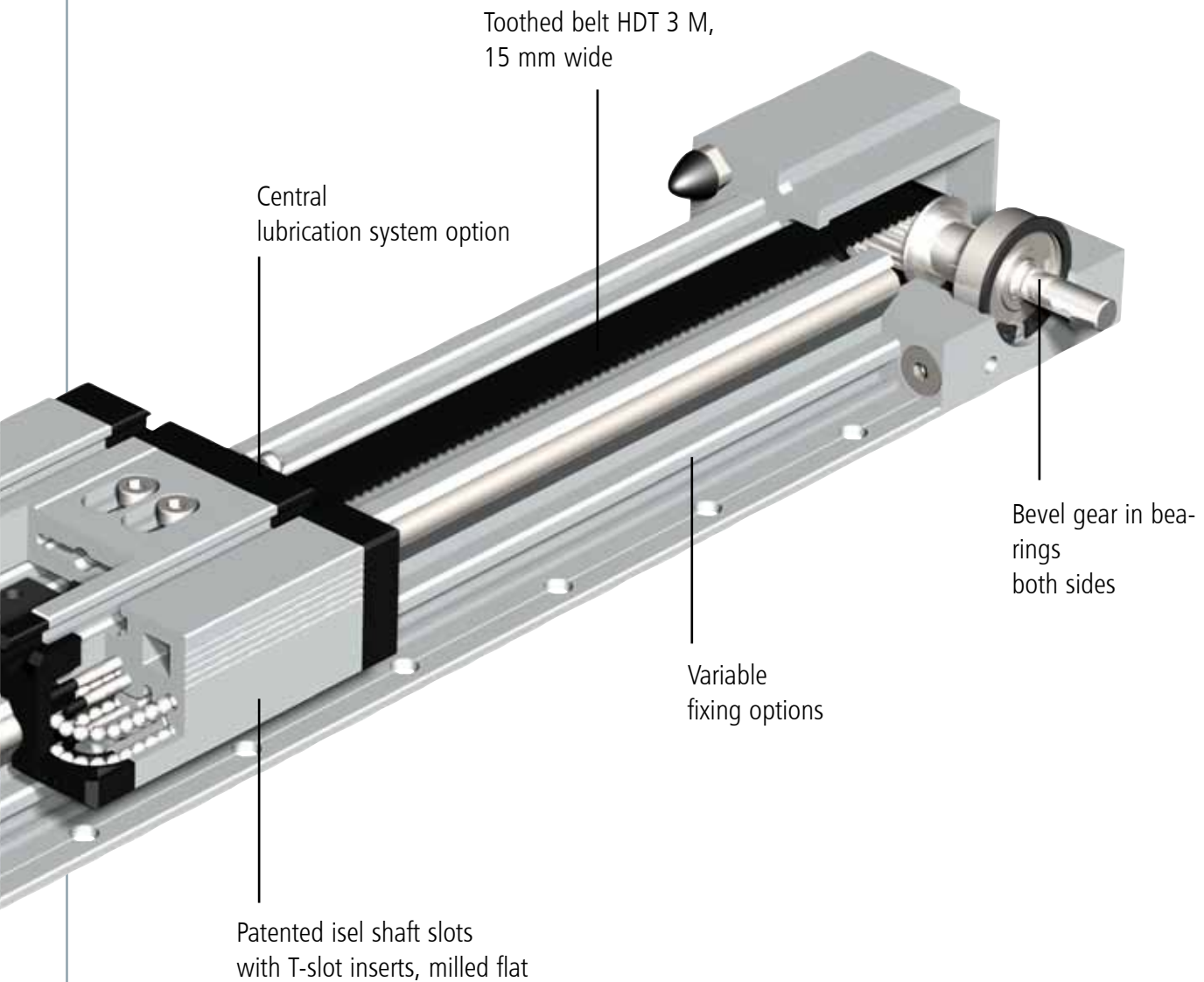

# Linear units with toothed belt drive

## LEZ 1

Guides  
and shaft slides  
also available stainless.



with shaft slide



with trolley

### Features

- aluminium profile, miniature linear guide LFS-8-2
- no-play feed with toothed belt drive
  - toothed belt with 3 mm interval, width 9 mm
- feed per turn: 60 mm
- repeatability less than or equal to  $\pm 0.2$  mm
- max. feed. 1.5 m/s

Accessories can be found on pages B-70.

#### Options:

- special 100 mm raster lengths to order, max. 6000 mm
- securing with integrated M6 tapped rail, raster 50 mm

### Ordering key

232 005 XXXX

#### Drives/Slides

##### Trolley

- 8 = without motor, with shaft slide
- 9 = without motor, with trolley

#### Profile lengths LFS-8-2 (mm)

- 298, 398, 498, 598, 675, 698, 798, 998, 1498, 1798, 1998, 2498, 2998  
 (e. g. 398 mm = 040  
 675 mm = 068)  
 Option: up to 6000 mm

### Technical specification

Belt type.....HTD 3M, width 9 mm  
 Slide weight.....0.430 kg  
 Weight without drive module.....1000 mm = 3 kg  
 specific weight of the toothed belt.....0.0225 kg/m  
 Trolley weight.....1.03 kg  
 specific guide weight.....0.200 kg/100 mm  
 Effective  $\varnothing$  of the synchronous disks.....19.10 mm  
 Moment of inertia of the synchronous discs..... $5.585 \times 10^{-7}$  kgm<sup>2</sup>  
 Feed per turn.....60 mm

Drive module with stepper motor MS-048 HT



Drive module with stepper motor MS-135 HT



### Load diagram

Permitted accelerated weights relative to the belt strength.\*

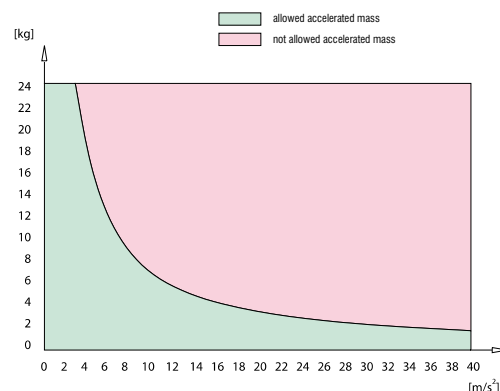

\* with vertical construction, the acceleration due to gravity ( $g = 9.81$  m/s<sup>2</sup>) must be taken into account

Bending data is on page B-9.

# Linear units

with toothed belt drive

## LEZ 1

### Dimensioned drawings

without motor, with shaft slides

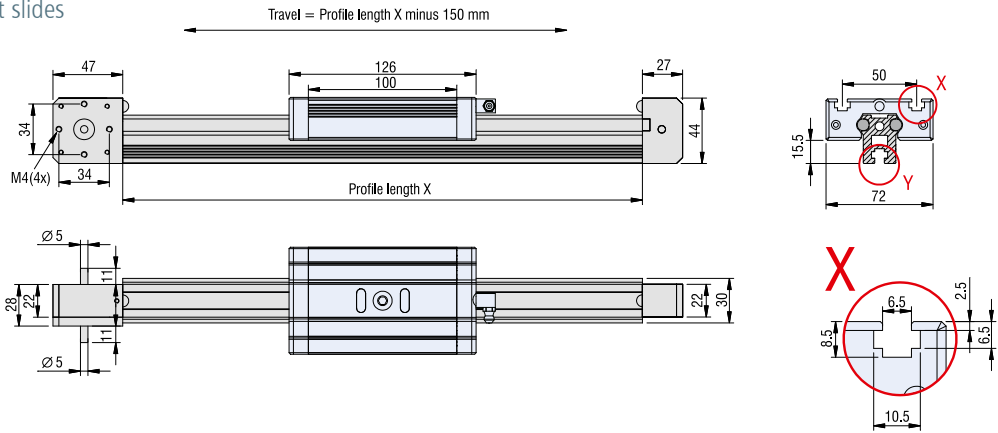

without motor, with trolley

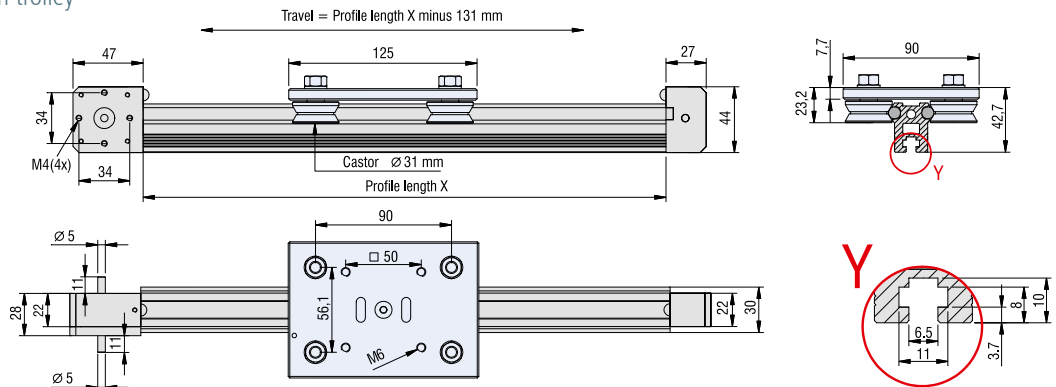

### Motor modules (Motor pin assignments are on Page B-50.)

Drive module with stepper motor MS-048 HT (direct drive)  
Feed: 60 mm / turn

Part no.: **396048 3015**

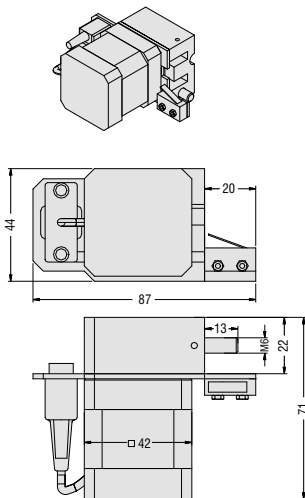

Total length with motor module:  
profile length + 94 mm

Drive module with stepper motor MS-048 HT (reduction 2:1)  
Feed: 30 mm / turn

Part no.: **396049 3015**

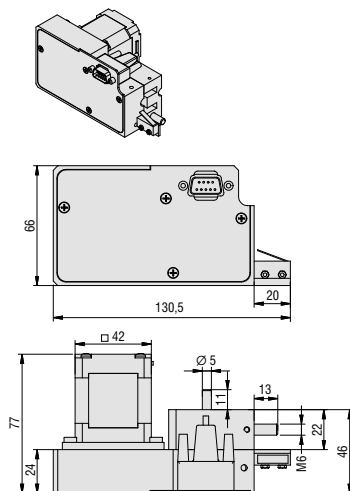

Total length with motor module:  
profile length + 138 mm

Drive module with stepper motor MS-135 HT (reduction 2:1)  
Feed: 30 mm / turn

Part no.: **396056 3015**

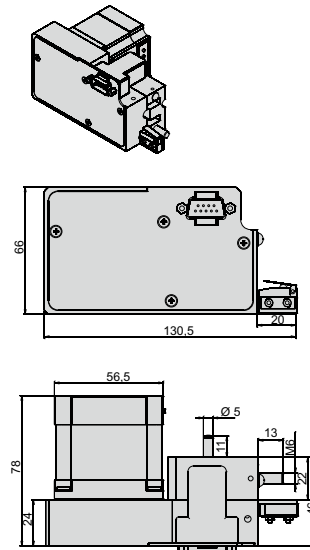

Drive module with servo motor EC-42 (reduction 2:1)  
Feed: 30 mm / turn

Part no.: **396407 3060**

Total length with motor module:  
profile length + 163,5 mm

# Linear units with toothed belt drive

## LEZ 2

Guides  
and shaft slides  
also available in a stain-  
less version



with shaft slide



with trolley

### Features

- aluminium profile with miniature linear guide LFS-8-5
- no-play feed with toothed belt drive - toothed belt with 5 mm interval, width 25 mm
- max. feed. 5 m/s
- shaft slides WS 3, L 176 × W 130 mm
- feed per turn: 70 mm
- repeat accuracy less than or equal to ± 0.2 mm
- available in lengths up to 6,000 mm

Accessories can be found on pages **B-70**

### Options:

- special 100 mm raster lengths available to order, max. 6000 mm
- also as direct drive with
  - stepper motor
  - Servomotor
- overrun limit switch with lead (only integrated in conjunction with drive module)

### Ordering key

232 002 XXXX

Profile lengths (mm)

696, 996, 1496, 1996,  
2496, 2996

(e. g. 696 mm = 070  
1496 mm = 150)

Option: up to 6000 mm

### Drives/Slides, Trolley

8 = without motor, with shaft slides

9 = without motor, with trolley

### Technical specification

Belt type.....	HTD 5M, width 25 mm
Slide weight.....	0,940 kg
Weight without drive module.....	1000 mm ≅ 7.9 kg
specific weight of the toothed belt.....	0.09 kg/m
Roller carriage weight.....	2.03 kg
specific guide weight.....	0.472 kg/100 mm
Effective diameter of the synchronous disks.....	Ø 22.28 mm
Moment of inertia of the synchronous disks.....	5.58·10 <sup>-6</sup> kgm <sup>2</sup>
Feed per turn.....	70 mm

### Linear guide rail LFS-8-5

Moment of inertia I <sub>x</sub> .....	137,48 cm <sup>4</sup>
Moment of inertia I <sub>y</sub> .....	27,98 cm <sup>4</sup>
Resistance torque W <sub>x</sub> .....	23,91 cm <sup>3</sup>
Resistance torque W <sub>y</sub> .....	13,09 cm <sup>3</sup>

### Load diagram

Permitted accelerated weights relative to the belt strength.\*

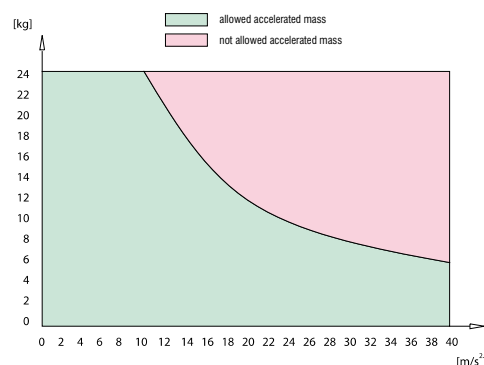

\* with vertical construction, the acceleration due to gravity (g = 9.81 m/s<sup>2</sup>) must be taken into account

Drive module  
with servo motor  
EC 60 L





# Linear units

with toothed belt drive

## LEZ 2

### Dimensioned drawings

without motor, with shaft slides

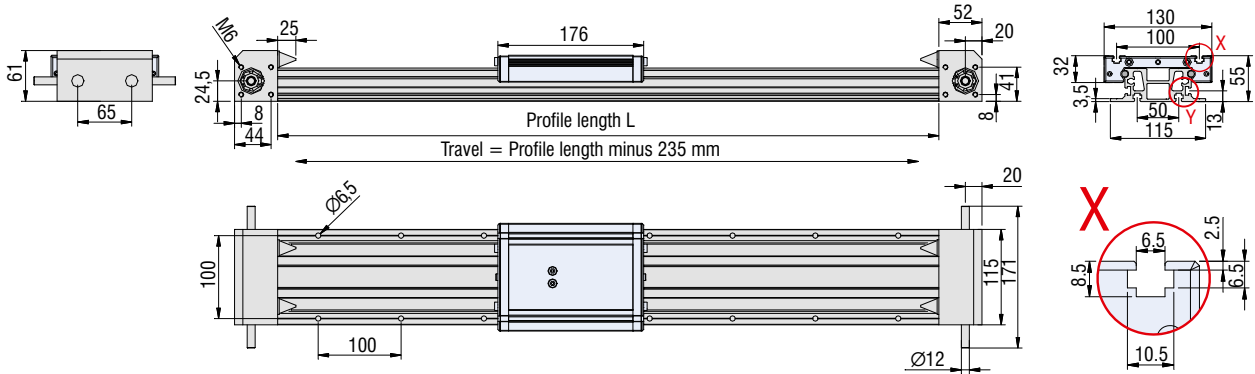

without motor, with trolley

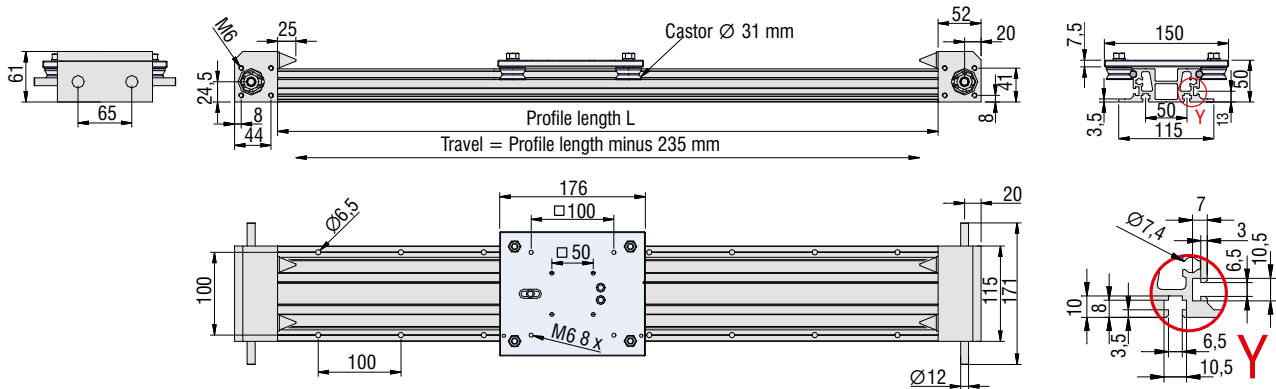

### Motor modules (Motor pin assignments are on Page B-50)

Drive module with stepper motor  
MS-600 HT (reduction 2:1)  
Feed: 35 mm / turn

Part no.: **396086 3060**

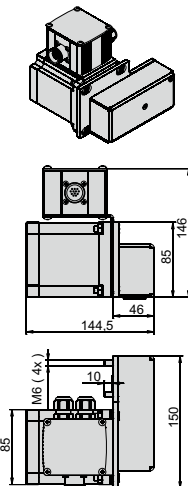

Drive module with EC servomotors  
(Reduction 2:1)  
Feed: 35 mm / turn

Part number	Motor module	Length L
396 415 3260	EC 60S with brake	151.5 mm
396 415 3060	EC 60S without brake	198.5 mm
396 423 3060	EC 60L	186.5 mm
396 444 3070	EC 86S	177.5 mm
396 466 3070	EC 86L	202.5 mm

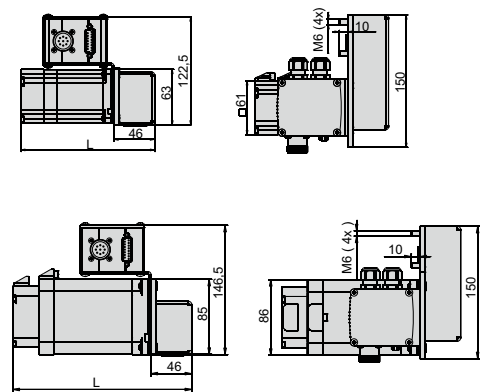
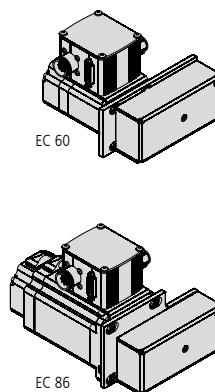

# Linear units

## with toothed belt drive

# LEZ 3

Guides and shaft slides also available stainless.



with shaft slide



with trolley

### Features

- aluminium profile, miniature linear guide LFS-8-4
- no-play feed with toothed belt drive, toothed belt with 5 mm interval, width 25 mm
- max. feed. 5 m/s
- shaft slides WS3, L176 × W130 mm
- Feed per turn: 70 mm or 150 mm
- repeat accuracy less than or equal to ± 0.2 mm
- limit or reference switch accuracy < 0.1 mm
- available in lengths up to 6,000 mm
- motor modules can be flange-mounted on left or right side

Accessories can be found on page B-70.

### Options:

- special 100 mm raster lengths available to order, max. 6000 mm

### Ordering key

23200X XXXX

#### Profile lengths (mm)

698, 998, 1498, 1998, 2498, 2998

(e. g. 698 mm = 070

1498 mm = 150)

#### Feed

6 = 150 mm / turn

7 = 70 mm / turn

#### Slides, trolley

0 = with shaft slides

1 = with trolley

### Technical specification

Belt type.....	HTD 5M, width 25 mm
Slide weight.....	0.940 kg
Weight without drive module.....	1000 mm <sup>1</sup> = 10.5 kg
specific weight of the toothed belt.....	0.09 kg/m
Roller carriage weight.....	2.03 kg
specific guide weight.....	0.648 kg/100 mm
Feed per turn.....	70 mm or 150 mm
Effective diameter of the synchronous disks	
Feed 70 mm/turn.....	22.28 mm
Feed 150 mm/turn.....	47.75 mm
Moment of inertia of the synchronous disks	
Feed 70 mm/turn.....	5.58E-6 kgm <sup>2</sup>
Feed 150 mm/turn.....	1,796.10 <sup>-4</sup> kgm <sup>2</sup>

### Load diagram

Permitted accelerated weights relative to the belt strength.\*

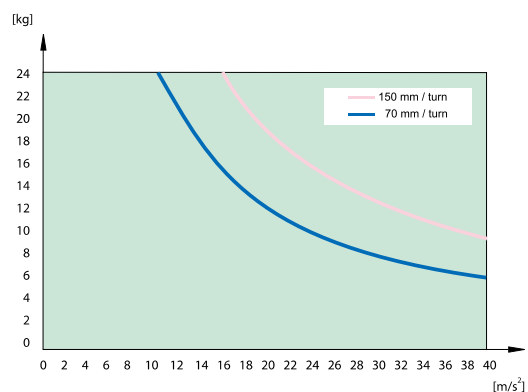

\* with vertical construction, the acceleration due to gravity (g=9.81 m/s<sup>2</sup>) must be considered

Bending data can be found on page B-9.

# Linear units

with toothed belt drive

## LEZ 3

### Dimensioned drawings

with shaft slides

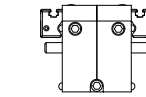
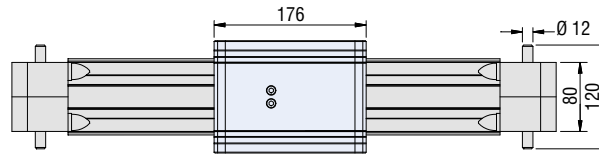
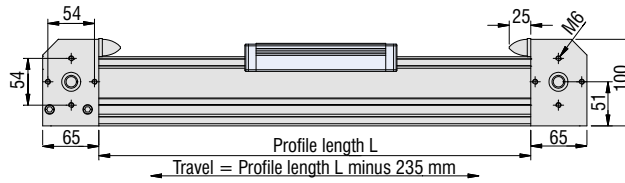
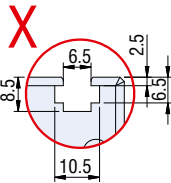
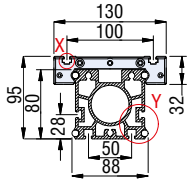

Feed: 70 mm/turn

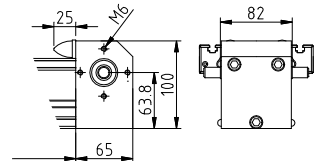

with trolley

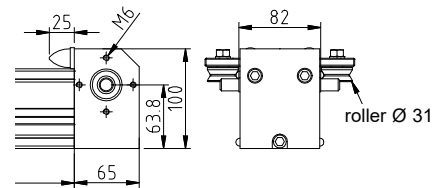
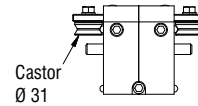
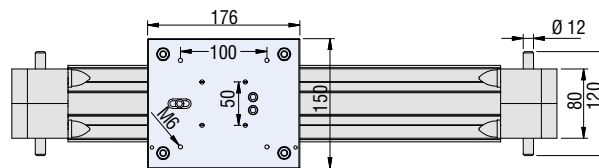
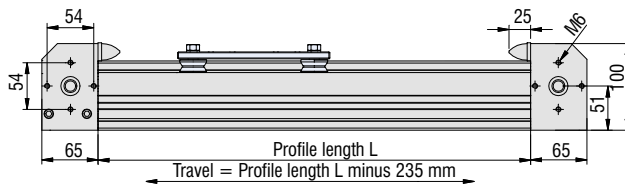
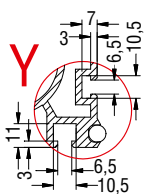
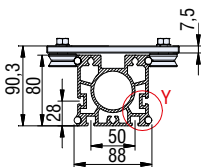

### Motor modules

(Motor pin assignments are on Page B-50)

Drive module with stepper motor  
(direct drive)

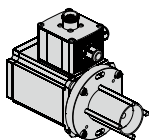

Part number	Motor module	
396 085 0060	MS 600 HT	right
396 085 0061	MS 600 HT	left
396 088 0060	MS 900 HT	right
396 088 0061	MS 900 HT	left

Drive module with EC servomotor  
EC 60 and EC 86 (direct drive)

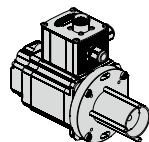

Part number	Motor module
396 423 006012	EC 60L
396 444 0070	EC 86S
396 466 0070	EC 86L

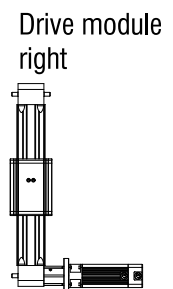
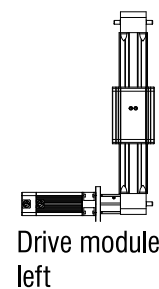

# Accessories

## LEZ 1



### Angle bracket

- for LEZ 1

Part-no.: **209110 0010**

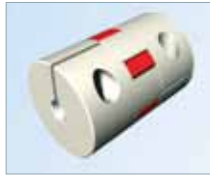

### 20/30 coupling

- for LEZ 1
- 1 VE = 1 coupling

Part-no.: **218001 5081**

### Shaft slides 1/70

- L 96 x W 72 x H 28.5 mm
- clamping surface plane milled, T-slide thread M6
- central greasing option, adjustable for no play
- weight: 0.35 kg
- option: stainless steel version

Part-no.: **223100 0070**  
stainless steel: **223101 0070**

### Transmission shaft

Length 1 m  
Part-no.: **227008 1000**

## LEZ 2

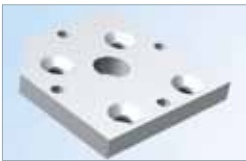

### Motor mounting plate

- for LEZ 2
- including fixing material
- for direct drive

Part-no.: **232199 0004**



### Coupling for transmission shaft

- for LEZ 2
- 1 VE = 2 pieces couplings

Part-no.: **218050 0002**

### Transmission shaft $\varnothing$ 25 mm

Length 1 m  
Part-no.: **219001 0125**  
Length 2 m  
Part-no.: **219001 0225**

### Vertical bearing for transmission shaft

VE 1 piece  
Part.-no.: **896202 5562**

## LEZ 3



### Coupling for transmission shaft

- for LEZ 3
- 1 VE = 2 pieces couplings

Part-no.: **218050 0002**

### Transmissions shaft $\varnothing$ 25 mm

Length 1 m  
Part-no.: **219001 0125**  
Length 2 m  
Part-no.: **219001 0225**

### Vertical bearing for transmission shaft

VE 1 piece  
Part.-no.: **896202 5562**

## Examples in use

### LEZ 1

- 2-axis flatbed configuration

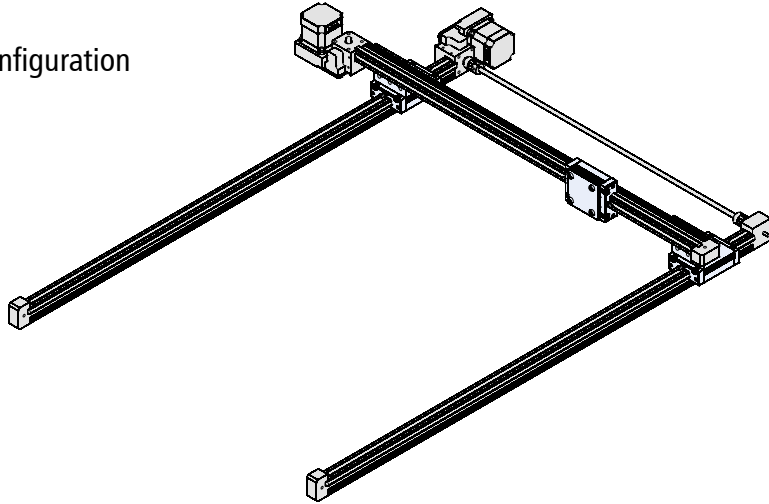

### Crossbench LEZ 1

- 2 x LEZ 1

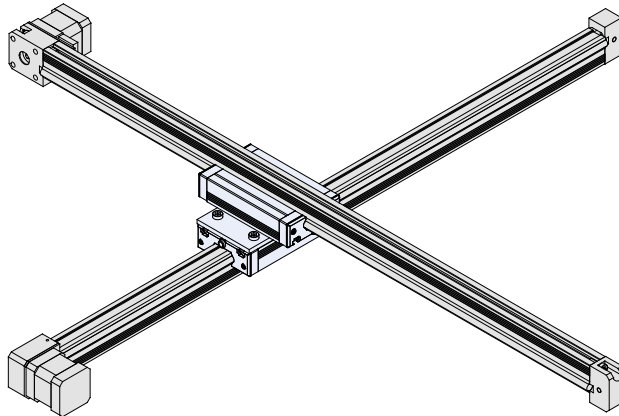

### 2-axis H-design

- 2 x LEZ 3
- 1 x LEZ 2
- Transmission shaft

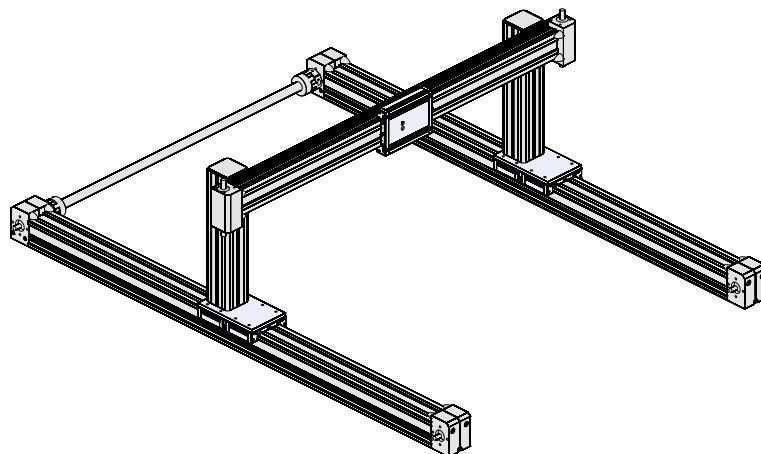

# Rotational units

# Overview

**RDH-M** Indexing table / Rotary unit

**B-74**



**RDH-S** Indexing table / Rotary unit

**B-76**



**RDH-XS** Indexing table / Rotary unit

**B-78**



# Rotational units

# Overview

ZD 30 Rotary unit

B-80

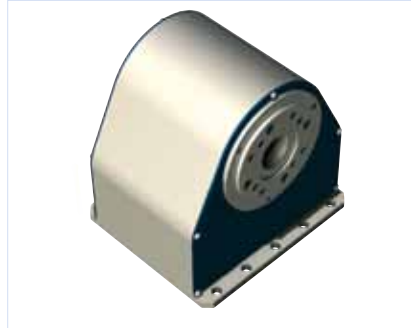

MD 1 Miniature rotary unit

B-82



Pin assignments

B-84

Transported loads  
Machining forces  
Feed

B-85



CAD data on our website [www.isel.com](http://www.isel.com) and on



## Indexing table / Rotary unit

## RDH-M



RDH-M as Indexing table  
(solid shaft design)

RDH-M as Rotary unit  
(hollow shaft design)



## Features

- with precision transmission
  - High load capacity, rigid drive bearing
  - Absence of play and high torsional rigidity
- reduction 1:51 or 1:101
- stepper or servomotor
- protection class IP 65
- stainless design
- transfer accuracy < 1 minute of arc
- repeatability <  $\pm 6$  seconds of arc
- available in solid or hollow shaft design
- no maintenance

For pin assignment see page **B-84**

For transport loads see page **B-85**

## Ordering key

2 6 6 2 X X 0 X 0 0

## Flanged shaft

- 0 = solid shaft
- 1 = hollow shaft

## Transmission reduction

- 0 = 101
- 1 = 51

## Motors

- 0 = stepper motor MS 200 HAT with encoder (400 imp., 3-channel, RS422)
- 3 = brushless EC servomotor EC 60S
- 4 = brushed DC servomotor DC 100
- 5 = Stepper motor without encoder

## Accessories



## Chuck assembly

3-jaw chuck  $\varnothing$  125  
Part no.: **269063 2125**  
\* including flange



## Aluminium T-slot plate

$\varnothing$  240 mm/PT 25  
Part no.: **269050 0240**  
  
 $\varnothing$  365 mm/PT 25  
Part no.: **269050 0365**



## Tailstock unit RE M

Part no.: **269100 2100**  
(1000 mm)  
Part no.: **269100 2150**  
(1500 mm)  
Part no.: **269100 2200**  
(2000 mm)



# Indexing table / Rotary unit

# RDH-M

## Technical specification

	stepper motor MS 200 HT *		EC servomotor EC 60S (brushless)		DC servo motor DC 100 (brushed)	
Reduction ratio	1:51	1:101	1:51	1:101	1:51	1:101
Nominal output speed [1/min]	4	2	22	11	22	11
	at 1500 Hz (225 1/min)		at 1100 1/min			
Max. output speed [1/min]	24	12	59	30	59	30
	at 8000 Hz		--			
Nominal torque [Nm]	24	46	9	17	7	14
	at 1500 Hz		--			
Max. torque (short term) [Nm]	--	--	42	80	39	73
Rated holding torque (static load) [Nm]	55	108	26	51	15	30
Max. transmission load [Nm]	98	157	98	157	98	157
	Limit for repeatable peak torque					
Dynamic load factor C [N]	21800					
Static load factor C <sub>0</sub> [N]	35800					
Weight [kg]	13.7					

\* Values for half-step operation

## Dimensioned drawings

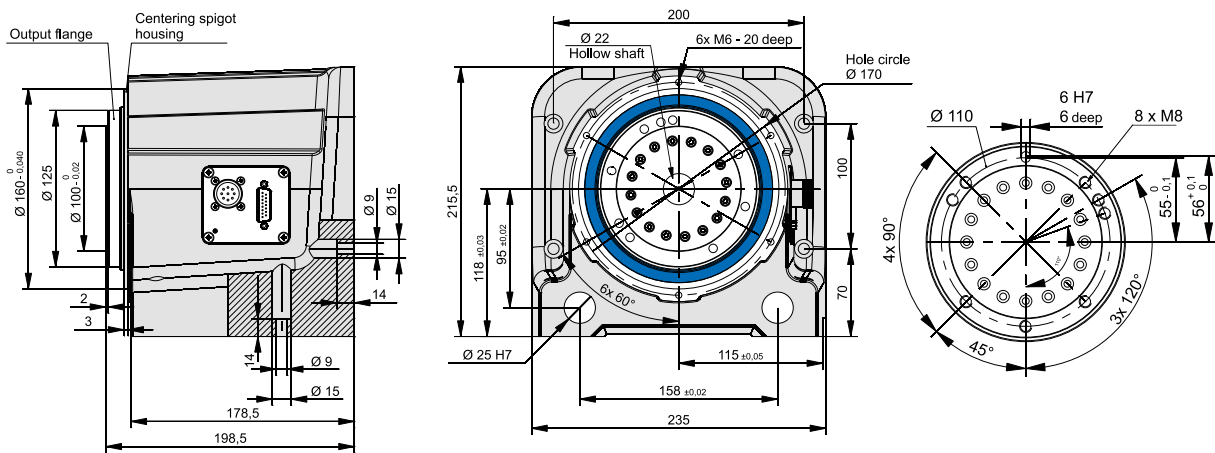

Versions	Part no.	L	A
Tailstock unit RE-M 1000 mm	269100 2100	1110	624.5
Tailstock unit RE-M 1500 mm	269100 2150	1610	1124.5
Tailstock unit RE-M 2000 mm	269100 2200	2110	1624.5

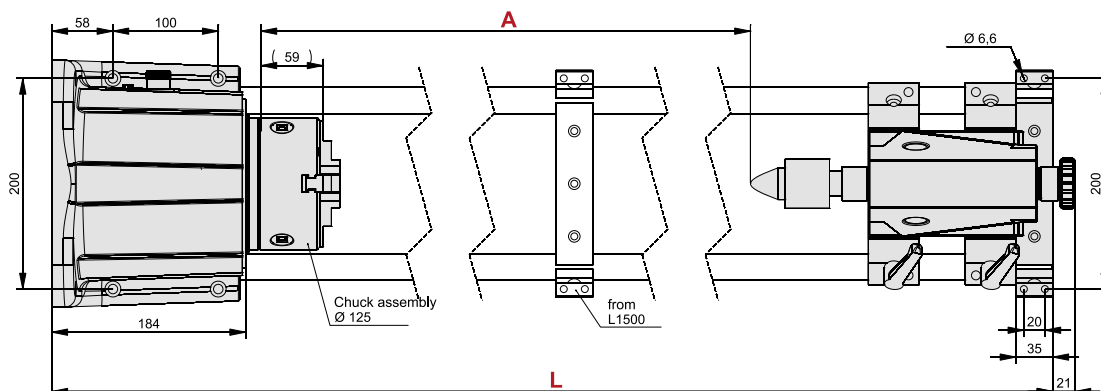

## Indexing table / Rotary unit

## RDH-S



RDH-S as Indexing table  
(solid shaft design)

RDH-S as Rotary unit  
(hollow shaft design)



## Features

- with precision transmission
  - high load capacity, rigid drive bearing
  - absence of play and high torsional rigidity
- reduction 1:51 or 1:101
- stepper or servomotor
- protection class IP 65
- stainless design
- transfer accuracy <math>< 1.5</math> minute of arc
- repeatability <math>< \pm 6</math> seconds of arc
- available in solid or hollow shaft design
- no maintenance

For pin assignment see page [B-84](#)

For transport loads see page [B-85](#)

## Ordering key

2 6 6 1 X X 0 X 0 0

## Flanged shaft

- 0 = solid shaft
- 1 = hollow shaft

## Transmission reduction

- 0 = 101
- 1 = 51

## Motors

- 0 = stepper motor MS 045 HT with encoder (400 imp., 3-channel, RS422)
- 2 = brushless DC servomotor RE 40
- 3 = brushless EC servomotor EC 42
- 5 = Stepper motor without encoder

## Accessories



## Chuck assembly

3-jaw chuck  $\varnothing$  65

Part no.: **269060 3065\***

3-jaw chuck  $\varnothing$  80

Part no.: **269063 2080\***

3-jaw chuck  $\varnothing$  100

Part no.: **269063 2100\***

\* including flange



## Circular plate

$\varnothing$  150 mm

Part no.: **269 050 0150**



## Tailstock unit RE S

for RDH-S

Part no.: **269100 1020** (200 mm)

Part no.: **269100 1030** (300 mm)

Part no.: **269100 1040** (400 mm)

Part no.: **269100 1050** (500 mm)

## Indexing table / Rotary unit

## RDH-S

## Technical specification

	stepper motor MS 045 HT *		EC servomotor EC 42 (brushless)		DC servo motor RE 40 (with brushes)	
Reduction ratio	1:51	1:101	1:51	1:101	1:51	1:101
Nominal output speed [1/min]	4      2		22      11		22      11	
	at 1500 Hz (225 1/min)		at 1100 1/min		at 1100 1/min	
Max. output speed [1/min]	24	12	59	30	69	35
	at 8000 Hz		--		--	
Nominal torque [Nm]	7	11	4.8	9.2	4.6	9
	at 1500 Hz		--		--	
Max. torque (short term) [Nm]	--	--	7	11	7	11
Rated holding torque (static load) [Nm]	7	11	7	11	7	11
Max. transmission load [Nm]	18	28	18	28	18	28
	Limit for repeatable peak torque					
Dynamic load factor C [N]	5800					
Static load factor C <sub>0</sub> [N]	8600					
Weight [kg]	4.6					

\* Values for half-step operation

## Dimensioned drawings

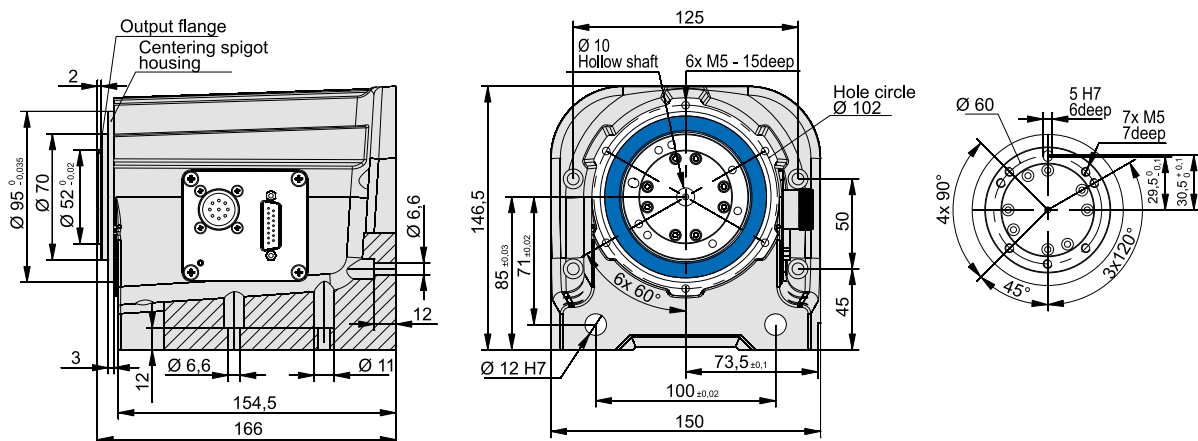

Versions	Part no.	L	A
Tailstock unit RE-S 200 mm	269100 1020	370	128
Tailstock unit RE-S 300 mm	269100 1030	470	228
Tailstock unit RE-S 400 mm	269100 1040	570	328
Tailstock unit RE-S 500 mm	269100 1050	670	428

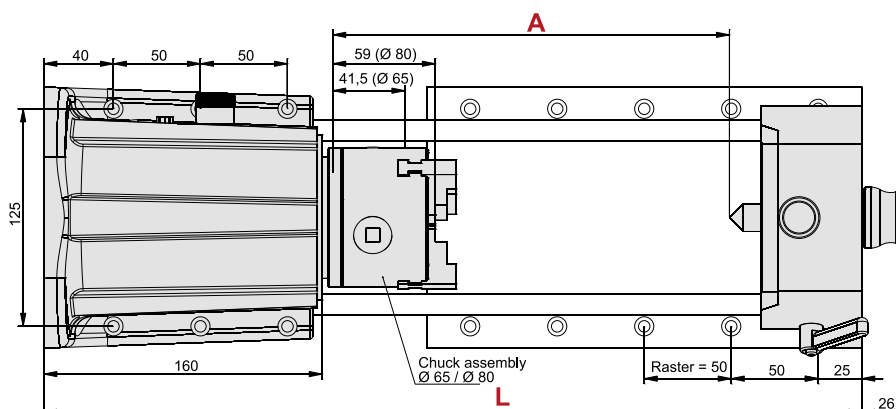

## Indexing table/Rotary unit

## RDH-XS



RDH-XS as Rotary unit

RDH-XS as Indexing table



## Features

- with precision transmission
  - high load capacity, rigid drive bearing
  - absence of play and high torsional rigidity
- reduction 1:50 or 1:100
- stepper or servomotor
- protection class IP 65
- stainless design
- transfer accuracy <math>< 2</math> minutes of arc
- repeatability <math>< \pm 1</math> minute of arc
- no maintenance

For pin assignment see page B-84

For transport loads see page B-85

## Ordering key

2 6 6 0 0 X 0 X 0 0

## Transmission reduction

0 = 100

1 = 50

## Motors

0 = stepper motor MS 045 HT with encoder (400 imp., 3-channel, RS422)

2 = brushed DC servomotor RE 40

3 = brushless EC servomotor EC 42

5 = Stepper motor without encoder

## Accessories



## Chuck assembly

3-jaw chuck  $\varnothing$  65Part no.: **269060 4065\***

\* including flange



## Tailstock unit RE XS

for RDH-XS

Part no.: **269100 0020** (200 mm)Part no.: **269100 0030** (300 mm)Part no.: **269100 0040** (400 mm)Part no.: **269100 0050** (500 mm)

## Indexing table/Rotary unit

## RDH-XS

## Technical specification

	stepper motor MS 045 HT *		EC servomotor EC 42		DC servo motor RE 40	
Reduction ratio	1:50	1:100	1:50	1:100	1:50	1:100
Nominal output speed [1/min]	5	2	22	11	22	11
	at 1500 Hz (225 1/min)		at 1100 1/min		at 1100 1/min	
Max. output speed [1/min]	24	12	59	30	70	35
	at 8000 Hz (1200 rpm)		--			
Nominal torque [Nm]	5	7	5	7	5	7
	at 1500 Hz (225 1/min)		--			
Max. torque (short term) [Nm]	--	--	5	7	5	7
Rated holding torque (static load) [Nm]	5	7	5	7	5	7
Max. transmission load [Nm]	9	14	9	14	9	14
	Limit for repeatable peak torque					
Dynamic load factor C [N]	392					
Static load factor C <sub>0</sub> [N]	392					
Weight [kg]	2.3					

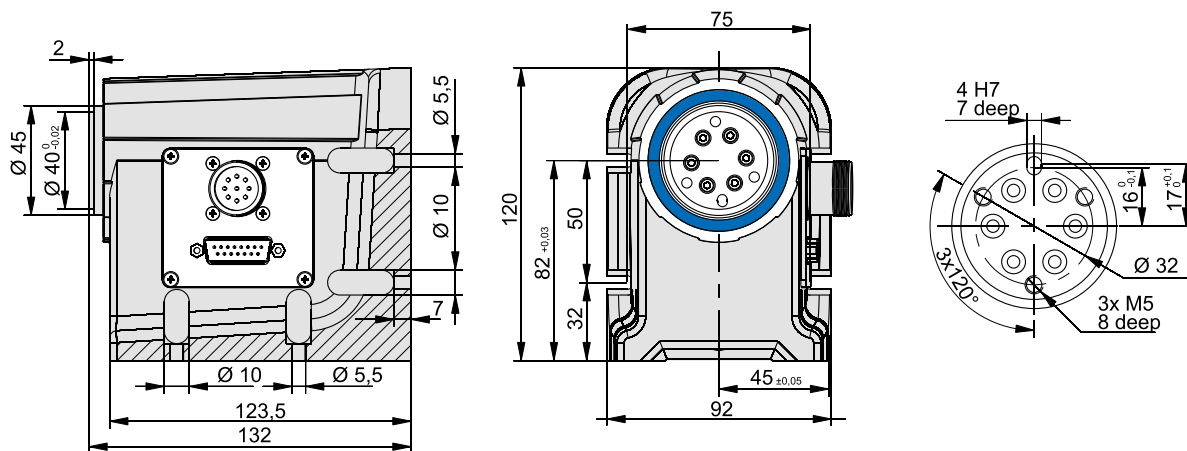
Dimensioned drawings Values for half-step operation

Versions	Part no.	L	A
Tailstock unit RE-XS 200 mm	269100 0020	325	117
Tailstock unit RE-XS 300 mmm	269100 0030	425	217
Tailstock unit RE-XS 400 mmm	269100 0040	525	317
Tailstock unit RE-XS 500 mmm	269100 0050	625	417

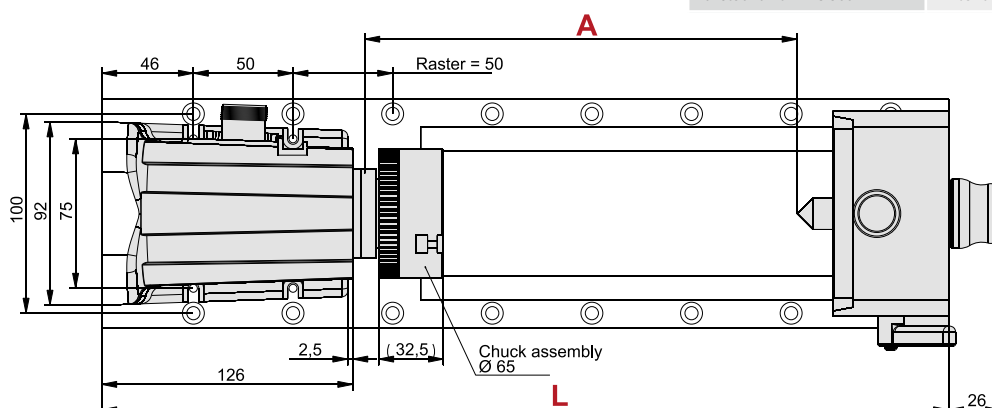

# Rotary unit

## ZD 30

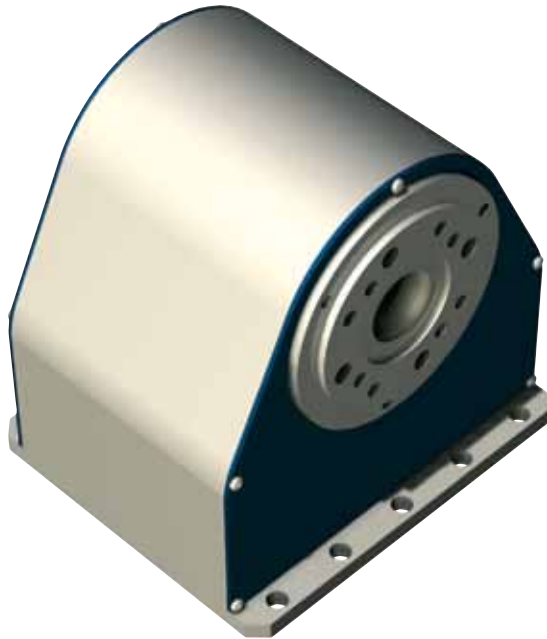

### Features

- low play toothed belt drive with stepper motor
- reduction 1 : 30
- shaft with  $\varnothing$  15 mm boring
- housing flange with inner cone SK 20
- weight: 2,9 kg

For pin assignment see page [B-84](#)

For transport loads see page [B-85](#)

### Options:

- CNC controller via Sub D

### Ordering data

ZD 30 rotary unit  
Part no.: **261100 0000**

### Accessories



**Chuck assembly**  
3-jaw chuck  $\varnothing$  65  
Part no.: **269060 2065\***



**Chuck assembly**  
3-jaw chuck  $\varnothing$  80  
Part no.: **269063 3080\***



**Collet holder**  
Clamping ring housing SK 20  
for tools  $\varnothing$  3 - 13 mm, with  
installation ring  
Part no.: **239122 9001**

Clamping rings are on  
page E-44.



**Tailstock unit RE-ZD30**  
200 mm Part no.: **269 100 1060** L 331  
300 mm Part no.: **269 100 1070** L 431  
400 mm Part no.: **269 100 1080** L 531  
500 mm Part no.: **269 100 1090** L 631

\* including flange

# Rotary unit

# ZD 30

## Technical specification

		stepper motor MS 045 HT *
Reduction ratio		0.0625
Output speed	[1/min]	0 - 40
Operating torque (0 - 1600 Hz)	[Nm]	12
Rated holding torque (static load)	[Nm]	20
Min. step (positional accuracy)	[arcmin]	2.5
Weight	[kg]	2.9

\* Values for half-step operation

## Dimensioned drawings

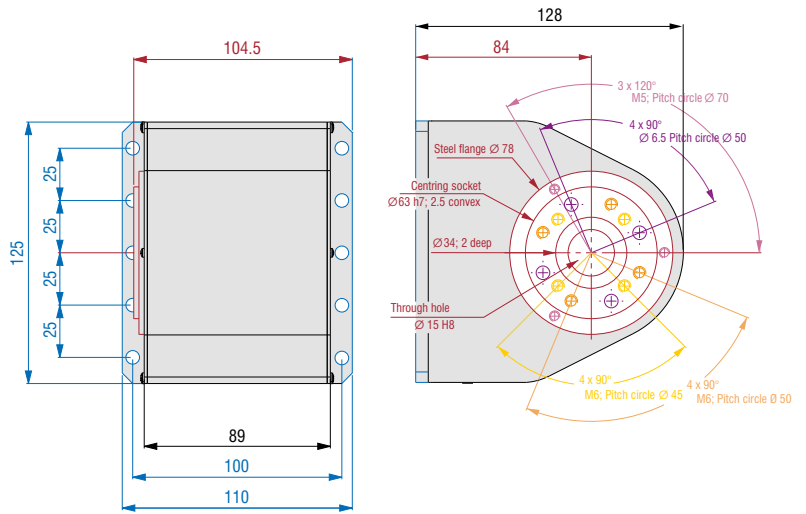

## Tailstock unit RE-ZD30

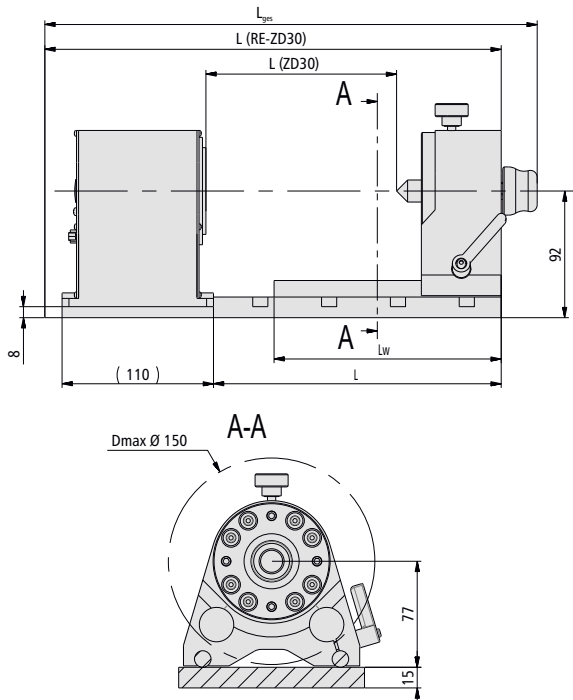

### Tailstock unit RE-ZD30 with chuck assembly Ø 65

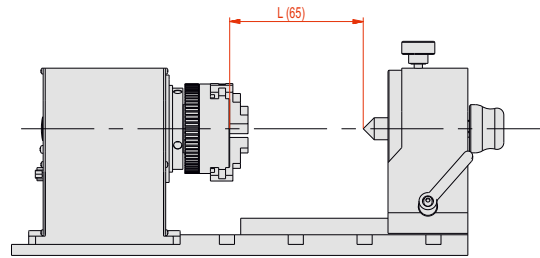

### Tailstock unit RE-ZD30 with chuck assembly Ø 80

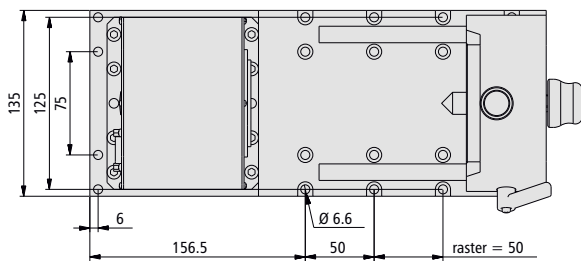
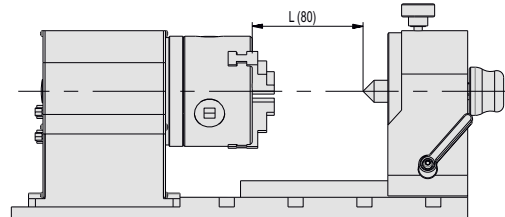

Version	Item-No.	L <sub>ges</sub>	L	L (ZD30)	L (RE-ZD30)	L <sub>w</sub>	L (65)	L (80)
RE-ZD30 200 mm	269100 1060	358	209	138.5	331.5	165	97	80.5
RE-ZD30 300 mm	269100 1070	458	309	238.5	431.5	265	197	180.5
RE-ZD30 400 mm	269100 1080	558	409	338.5	531.5	365	297	280.5
RE-ZD30 500 mm	269100 1090	658	509	438.5	631.5	465	397	380.5

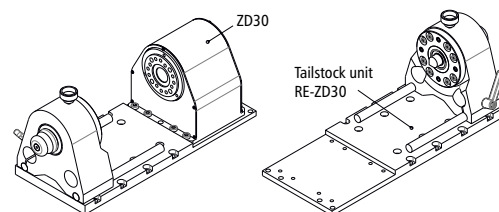

# Mini rotary unit

## MD 1

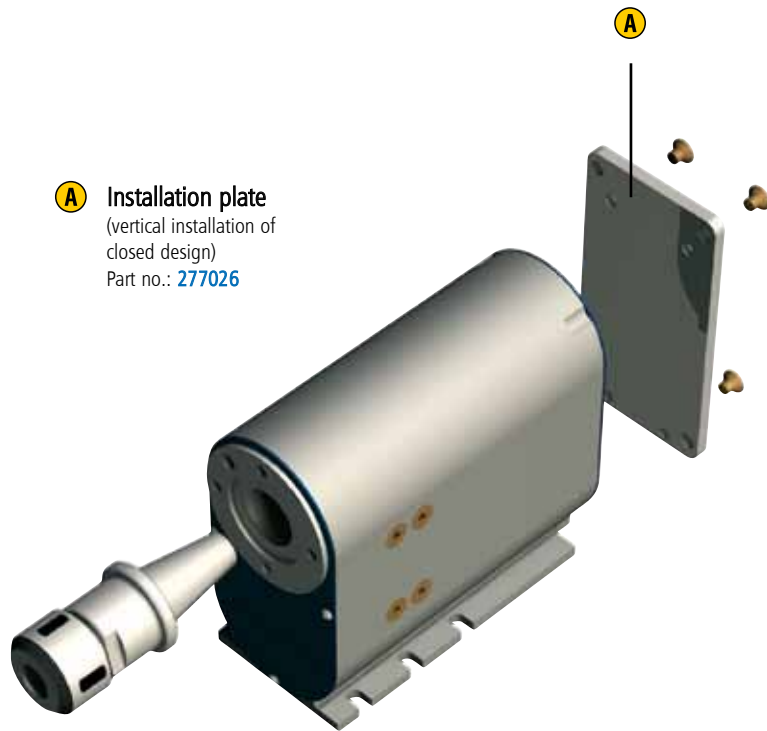

**A** **Installation plate**  
(vertical installation of  
closed design)  
Part no.: **277026**

### Features

- low play toothed belt drive with stepper or DC servo motor
- reduction 1 : 20
- shaft Ø9 mm with boring
- housing flange with inner cone SK 20
- weight:  
depending on design, from 1.35 kg

For pin assignment see page **B-84**

For transport loads see page **B-85**

#### Options:

- additional installation plate  
(vertical installation possible)
- CNC controller

### Ordering key

**261010 0X10**

#### Motors

- 0** = MS 045 HT stepper motor
- 2** = DC servomotor RE 40, with brushes
- 3** = brushless EC servomotor EC 42

### Accessories



#### Chuck assembly

3-jaw chuck Ø 65

Part no.: **269060 2065\***

\* incl. Flange



#### Collet holder

Collet holder SK 20  
for tools Ø 3 - 13 mm, with  
installation ring

Part no.: **239122 9001**

Collets are on page E-44.



# Mini rotary unit

# MD 1

## Technical specification

	MS 045 HT stepper motor *	DC servomotor RE 40	EC servomotor EC 42
Reduction ratio	1:20	1:20	1:20
Output speed [1/min]	0 - 60	0 - 175	0 - 150
Operating torque (0 - 1600 Hz) [Nm]	8	--	--
Rated torque [Nm]	--	3	3.2
Rated holding torque (static load) [Nm]	14	3.9	4
Min. step (positional accuracy) [arcmin]	3.5	2	2
Gewicht [kg]		1.35	

\* Values for half-step operation

## Dimensioned drawings

	Length L per step	Length L for DC servo
closed design	129 mm	180 mm
closed with installation plate	133 mm	184 mm

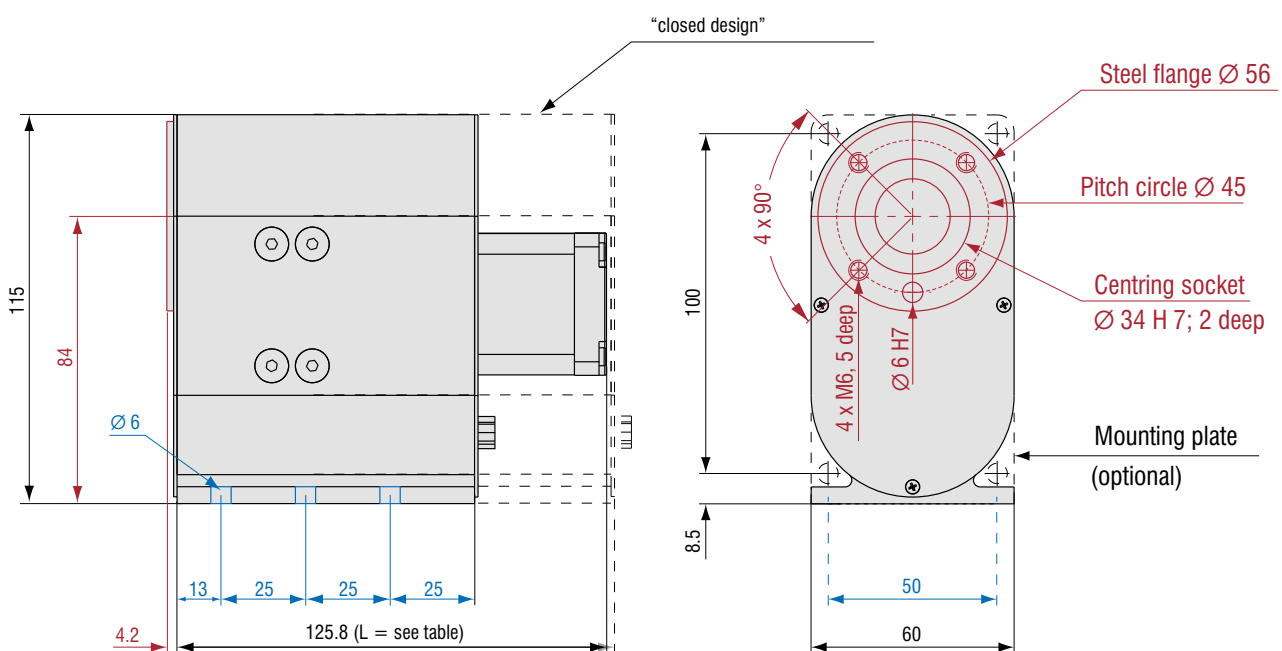
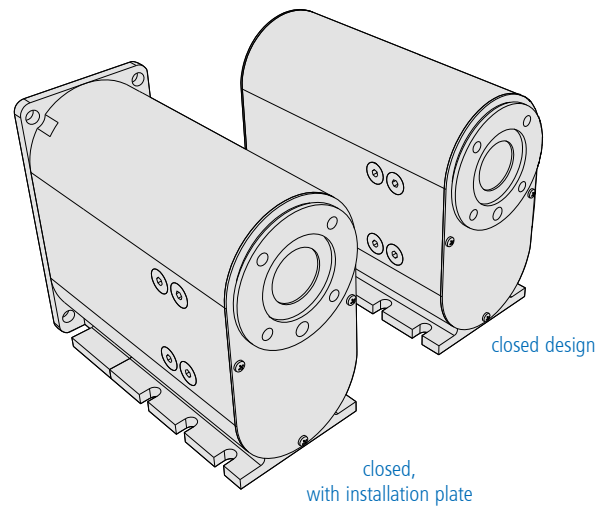

# Motor pin assignments

## Pin assignment for 12-pin stepper motors

(for RDH)

### Motor connection

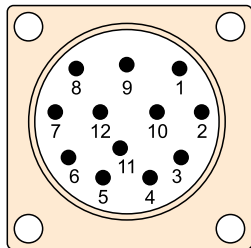

Plug side view of pin insert

M23 12-pin Pin	
1	Motor phase 1A
2	Motor phase 1B
3	Motor phase 2A
4	Motor phase 2B
5	+24V switch
6	+24V brake
7	GND switch
8	GND brake
9	Limit switch 1
10	Limit switch 2
11	---
12	---
Housing - cable shield	

## Pin assignment for 9-pin stepper motors

(for iZD 54, MD 1, ZD 30, ZR 20, ZDS 2030)

### Motor connection

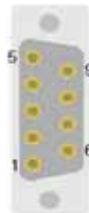

Plug side view of pin insert

Sub-D 9-pin Pin	
1	Motor phase 1A
2	Motor phase 1B
3	Motor phase 2A
4	Motor phase 2B
5	+24V switch
6	+24V brake
7	Limit switch 2
8	GND brake
9	Limit switch 1
Housing - cable shield	

## Pin assignment for stepper motors with encoder

(for RDH)

### Motor connection

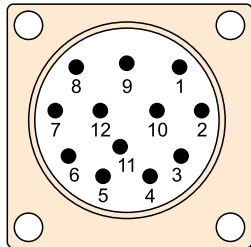

Plug side view of pin insert

M23 12-pin Pin	
1	Motor phase 1A
2	Motor phase 1B
3	Motor phase 2A
4	Motor phase 2B
5	+24V switch
6	+24V brake
7	GND switch
8	GND brake
9	Limit switch 1
10	Limit switch 2
11	---
12	---
Housing - cable shield	

### Encoder connection

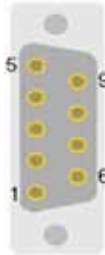

Plug side view of pin insert

Sub-D 9-pin Pin	
1	+5V encoder
2	Encoder track A
3	Encoder track B
4	Encoder track Z
5	---
6	GND encoder
7	Encoder track/A
8	Encoder track/B
9	Encoder track/Z
Housing - cable shield	

## Pin assignment for DC servo motors with brushes (BDC)

### Motor connection

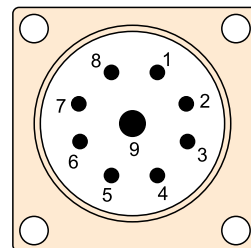

Plug side view of pin insert

M23 9-pol. (8+1) pin	
1	Motor phase 1 (V+)
2	Motor phase 1 (V-)
3	Motor phase 1 (V+)*
4	Motor phase 1 (V-)*
5	+24V brake
6	GND brake
7	---
8	---
9	Earthing lead
Housing - cable shield	

\* Part motor phase connection over 2 wires.

### Encoder connection



Plug side view of pin insert

Sub-D 15-pin Pin	
1	---
2	+5V encoder
3	Encoder track/Z
4	Encoder track/B
5	Encoder track/A
6	+24V switch
7	Limit switch 1
8	GND switch
9	---
10	GND encoder
11	Encoder track Z
12	Encoder track B
13	Encoder track A
14	Reference switch
15	Limit switch 2
Housing - cable shield	

## Pin assignment for brushless EC servomotors (BLDC) 48V

### Motor connection

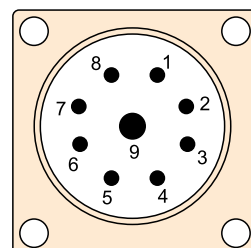

Plug side view of pin insert

M23 9-pol. (8+1) pin	
1	Motor phase U
2	Motor phase V
3	Motor phase W
4	---
5	+24V brake
6	GND brake
7	---
8	---
9	Earthing lead
Housing - cable shield	

### Encoder connection



Sub-D 15-pin Pin	
1	Hall signal A
2	+5V encoder/Hall
3	Encoder track/Z
4	Encoder track/B
5	Encoder track/A
6	+24V switch
7	Limit switch 1
8	GND switch
9	Hall signal B
10	GND encoder
11	Encoder track Z
12	Encoder track B
13	Encoder track A
14	Hall signal C
15	Limit switch 2
Housing - cable shield	

Turn/tilt/rotation units:

# Transport loads, machining forces, feed

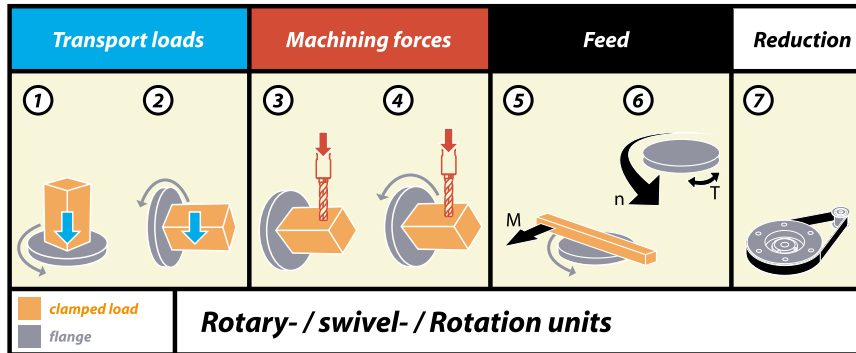

Rotary or tilting units	1*	2*	3	4	5	6	7
RDH-M (step)	100 kg	45 kg	55 Nm	24 Nm	24 Nm	4 rpm	1:51
RDH-M (step)	160 kg	70 kg	108 Nm	45 Nm	45 Nm	2 rpm	1:101
RDH-M (EC-servo, brushless)	110 kg	50 kg	26 Nm	9 Nm	9 Nm	22 rpm	1:51
RDH-M (EC-servo, brushless)	180 kg	80 kg	51 Nm	17 Nm	17 Nm	11 rpm	1:101
RDH-S (step)	30 kg	15 kg	7 Nm	7 Nm	7 Nm	4 rpm	1:51
RDH-S (step)	48 kg	24 kg	11 Nm	11 Nm	11 Nm	2 rpm	1:101
RDH-S (EC-servo, brushless)	30 kg	15 kg	7 Nm	4.6 Nm	4.6 Nm	22 rpm	1:51
RDH-S (EC-servo, brushless)	48 kg	24 kg	11 Nm	4.6 Nm	9.2 Nm	11 rpm	1:101
RDH-S (DC-servo)	25 kg	13 kg	7 Nm	4.6 Nm	4.6 Nm	22 rpm	1:51
RDH-S (DC-servo)	40 kg	20 kg	11 Nm	8.7 Nm	8.7 Nm	11 rpm	1:101
RDH-XS (step)	30 kg	10 kg	5 Nm	5 Nm	5 Nm	24 rpm	1:50
RDH-XS (step)	30 kg	10 kg	7 Nm	7 Nm	7 Nm	12 rpm	1:100
RDH-XS (EC-servo, brushless)	30 kg	10 kg	5 Nm	5 Nm	5 Nm	59 rpm	1:50
RDH-XS (EC-servo, brushless)	30 kg	10 kg	7 Nm	7 Nm	7 Nm	30 rpm	1:100
RDH-XS (DC-servo)	30 kg	10 kg	5 Nm	5 Nm	5 Nm	70 rpm	1:50
RDH-XS (DC-servo)	30 kg	10 kg	7 Nm	7 Nm	7 Nm	35 rpm	1:100
MD 1 (step)	5 kg	2.5 kg	14 Nm	8 Nm	8 Nm	60 rpm	1:20
MD 1 (DC servo)	6 kg	3 kg	3.9 Nm	3 Nm	3 Nm	175 rpm	1:20
MD 1 (EC servo, brushless)	6 kg	3 kg	4 Nm	3.2 Nm	3.2 Nm	150 rpm	1:20
ZR 20 (step)	10 kg	5 kg	14 Nm	8 Nm	8 Nm	60 rpm	1:20
ZD 30 (step)	14 kg	8 kg	20 Nm	12 Nm	12 Nm	40 rpm	1:30

\*) Guideline values will vary according to application.

# electron

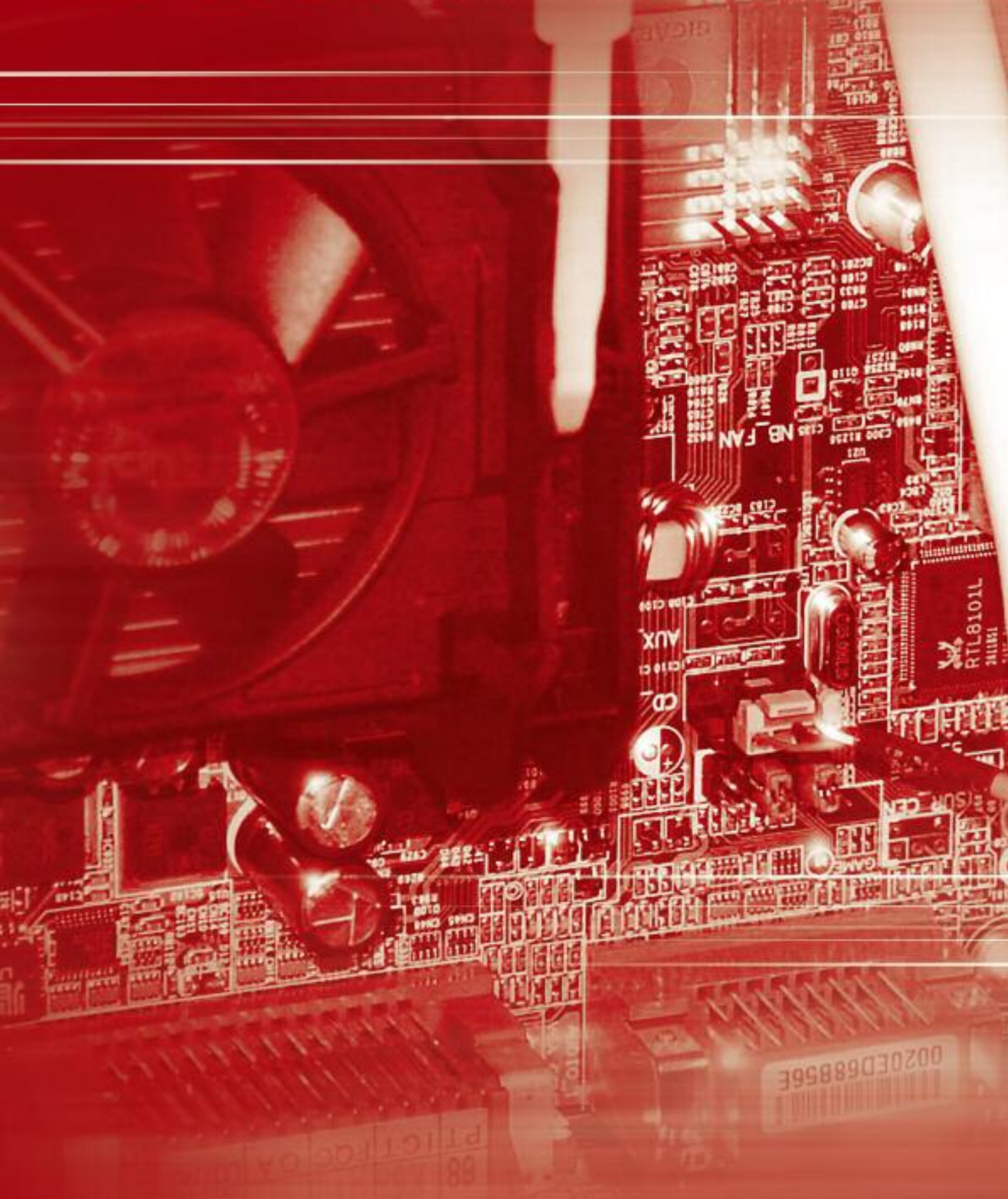



## ELECTRONICS

Controllers ..... C-2

# Overview

## CNC control units

C-3



iOP 19-TFT  
iOP 19-CPU

## Step controller

Single axis controller

C-4



IT 116 Flash

## Step controller

Multiple axis controller

C-5



iMC-S8

## Servo controller

Single axis controller

C-6



MC 1-20  
MC 1-40

## Servo controller

Multiple axis controller

C-7



iPU-DC / iPU-EC



iCU-DC / iCU-EC

## CAN-CNC controller

Overview

C-9



# CNC control units

# iOP-19-TFT / iOP-19-CPU



## General

The CNC control units iOP-19 are a revised version of the previous isel control panels iBP. All experiences have been incorporated into the new development of the iOP-19. They have an integrated 19" touch screen monitor, a silicone keyboard as well as a control panel with stainless steel buttons and emergency stop switch. A PC can be connected and operated via the lead-out standard connecting cables. The iOP-19-CPU has an isel CAN.

## Dimensioned drawings

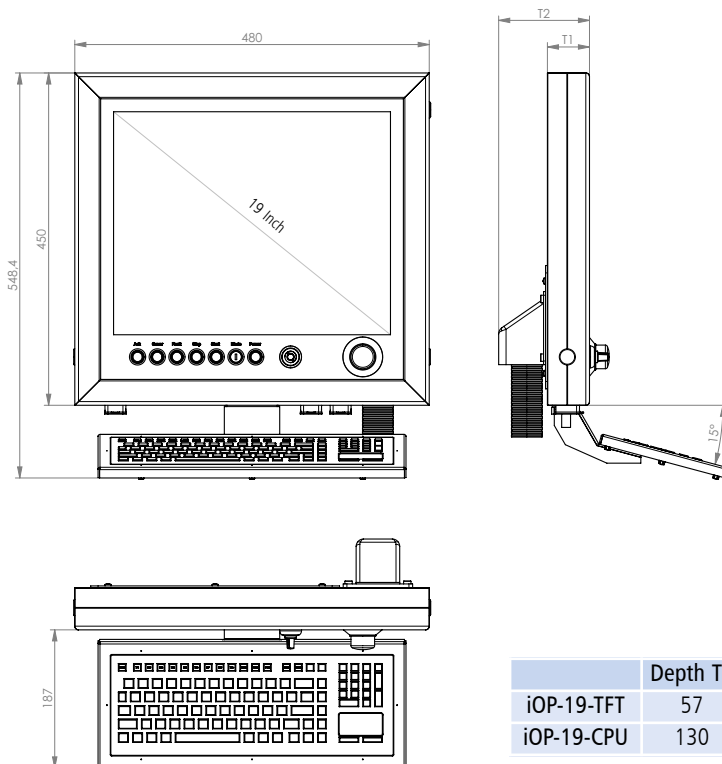

Technical specifications subject to change.

## Common features

- robust aluminium housing (standard color: RAL 3011 / red)
- 19" touch screen display
- high-quality silicon keyboard (protection class: IP68)
  - in German and English
  - 105 keys, with touchpad
- easy mounting option for keyboard
- user-friendly approach via high-adjustable arm
- easy mounting via VESA mounting 100/100
- 3 USB ports

### Features iOP-19-TFT

- protection class IP 50
- dimensions (without keyboard): W 480 x D 123 x H 450 mm
- weight: approx. 15kg

### Features iOP-19-CPU

- protection class IP 40 and IP 50
- motherboard 64 bit / CPU IntelCore I3
- additional a network connection (LAN)
- dimensions (without keyboard): W 480 x D 196 x H 450 mm
- weight: approx. 16kg

## Options

- foot
- simple keyboard and mouse tray
- Two-hand operation
- RAL 9005 (black) or graphite hammer

## Ordering Data

Control panel **iOP-19-TFT**, RAL 3011 (red)  
Part-no.: **371100 1000**

Control panel **iOP-19-CPU**, RAL 3011 (red)  
Part-no.: **371101 1000**

German keyboard, RAL 3011 (red)  
Part-no.: **371200 0001**

English keyboard, RAL 3011 (red)  
Part-no.: **371200 0002**

Swivel arm for profile PS 50  
Part-no.: **371050 2020**

Swivel arm for profile PS 80  
Part-no.: **371050 2040**

Swivel arm for profile 100  
Part-no.: **371050 2050**

Swivel arm for profile 125  
Part-no.: **371050 2060**

Swivel arm for profile PS 140  
Part-no.: **371050 2070**

Swivel arm for profile PV 150  
Part-no.: **371050 2080**

# Step controller IT116 Flash

## Single axis controller



Figure:  
IT 116 Flash front



Figure:  
IT 116 Flash back side

### General

The **IT 116 Flash step controller** is a freely programmable compact controller for a linear or circular axis with 2-phase stepper motor. The step controller comprises an intelligent step motor stage, a processor core with Flash memory for downloading/storing the PAL-PC user program and the clocking/direction signal generation for the final stage of the motor, the necessary power supply units, a safety circuit (Stop category 0 to EN 60204) and a casing with mains input filter and control elements.

The integrated operating system in the Flash memory of the processor core supports both

- **DNC controller mode:** PC/laptop connected permanently with the step controller via the serial interface

and the

- **CNC controller mode:** the step controller works independently, without PC coupling of the stored user program (standalone).

### Ordering information

IT 116 Flash step controller (115V AC, 60 Hz) Part no.: **381016 0115 \***

IT 116 Flash step controller (230V AC, 50 Hz) Part no.: **381016 \***

**\* including PAL-PC**

### Accessories

Motor lead

M23 12-pin socket - SubD 9-pin Pin  
Part no.: **392755 0500** (5m)

Motor lead

SubD 9-pin socket - plug 1:1  
Part no.: **392781 0500**

Other lengths on request.

### Features

- final output stage  
48 V DC / 4.2 A peak  
for 2-phase stepper motors
- max. 25,600 microsteps/turn
- mains voltage:  
115V AC/230V AC, 50...60 Hz
- automatic current sink at  
50% phase current at  
motor speed < 1 rpm
- motor current/microstep resolution  
variable with DIP switch
- integrated 32-bit RISC processor  
(Embedded controller) with Flash  
memory for firmware and  
PAL PC user program
- RS-232 interface (front) for  
coupling with PC/notebook  
(program download)
- control signals:  
program start/stop, reset on  
controller back side
- 4 optically isolated signal inputs  
(Signal voltage: 24 V DC)
- 4 relay outputs (24 V DC, 300 mA)
- motor brake controller (24 V DC)
- remote plug on rear of controller  
for external EMERGENCY SHUT-  
DOWN (2-channel), ext. power on
- euro cooling rib casing
- programming with PAL-PC 2.1  
for Win2000, XP, Vista, 7
- dimensions  
W 105 × H 111 × D 320 mm

### Scope of delivery

- controller in cassette casing
- mating plug (I/O, pulse, remote)
- serial interface lead (SubD9 - RJ 45)
- 230V AC mains lead
- PAL-PC software CD
- operating instructions
- programming instructions

Technical specifications subject to change.



# Step controller

## Multiple axis controller

# iMC-S8



Figure:  
iMC-S8 step controller as  
bench version and with 19" housing

### Features

- 32-bit RISC processor with Flash memory for user program
- final output stages
  - step resolution and motor current adjustable via variable DIP switch
  - automatic current sink
- acceleration, start-stop frequency and step output frequency variable
- both hardware limit switches configurable
- door controller/hood controller
- control elements in the front of the casing
- external EMERGENCY SHUTDOWN and POWER connection for integration in higher level safety circuits
- connection for external control signals, such as START, STOP, RESET (only CNC mode)
- 230V connection for milling spindle (100-230V AC)
- 0 .. 10V analogue output for external frequency converter for speed-controlled main spindle
- programming/operation
  - PAL-PC in CNC mode (in the scope of delivery)
  - Remote (optional: ProNC) in DNC mode
  - isel @ - format in CNC/DNC modes

### General

The **iMC-S8** step controller is a freely programmable compact controller for linear or circular axes with 2-phase step motors.

The controller integrates all the necessary components (power supply, safety circuit, power electronics, core processor, interfaces, operating elements) that are needed to control individual spindles all the way to entire machines. It has an intelligent core module that is controlled and programmed via a RS232 interface. The core module also converts the commands programmed in the user program into clocking/direction signals for the connected final stages. Depending on the purpose, the **iMC-S8** controller can be used either in CNC or in DNC mode.

In CNC mode, the processor processes the CNC program which was previously produced with PAL-PC and stored in the controller's Flash memory.

In DNC mode, the **iMC-S8** controller is connected permanently with a control computer (PC, laptop) via a serial interface (RS232). Processing is carried out via the isel control software Remote.

### Technical specification

- broadband mains supply  
100 - 250V AC, 50..60Hz
- processor
  - Flash memory 128 kB, capacity to store 350 commands
  - max. step output frequency 40 kHz
- final stages
  - power supply 48 VDC
  - peak current: 1,0 - 4,2 A (MD 24)  
2,8 - 7,8 A (MD 28)
  - step resolution: 400-51200 steps
- Inputs/outputs
  - 16 inputs (24V DC)
  - 16 outputs (24V DC/300mA, Itot 2A)
  - 1 relay output (230V AC, max. 6A)
  - 1 analogue output (0 - 10V)
- RS232 operating/programming interface
- stop category 1, safety category 2
- versions:
  - bench casing  
W 475 × H 410 × D 187.5 mm
  - 19" housing  
W 482.5 × H 410 × D 175.5 mm

### Ordering information

3 8 3 3 2 0 X X 1 X

#### Variant

- 1 = 19"-housing
- 2 = bench housing

#### Drive module

- 0 = MD 28
- 1 = MD 24

#### Numbers of axis

- 2 = 2 axis
- 3 = 3 axis
- 4 = 4 axis

### Scope of delivery

Controller, mating plug (I/O, pulse, Remote), serial interface lead (null modem), 230V AC mains lead, PAL-PC software CD, operating instructions, programming instructions

### Accessories

Motor lead M23 plug - M23 socket

Part no.: **392750 0300** (3m)

Part no.: **392750 0500** (5m)

Motor lead M23 plug - SubD9 socket

Part no.: **392752 0300** (3m)

Part no.: **392752 0500** (5m)

Controller software - Remote

Part no.: **Z12-334500**

Controller and programming software ProNC

Part no.: **Z11-333500**

Technical specifications subject to change.

# Single axis controller MC1-10/20/40

iMD single axis controller for isel linear units

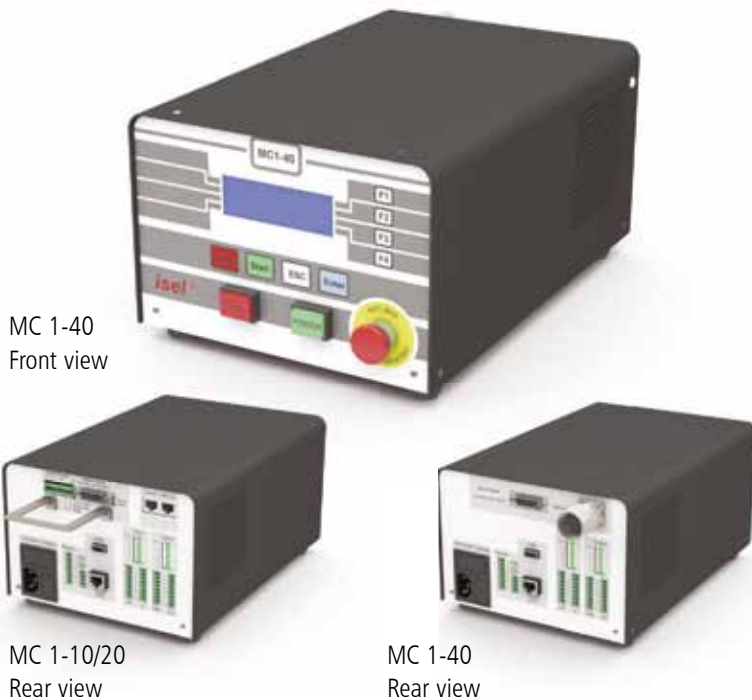

MC 1-40  
Front view

MC 1-10/20  
Rear view

MC 1-40  
Rear view

## General

MC 1 series servo-controllers are freely-programmable compact controllers for linear or rotating units with servomotors. The single axis controllers integrate all the components (interfaces, motion controller, power supply, drive controller, safety circuit, control elements) needed for axis control in compact bench housings. The supplied PAL-PC software can be used for programming.

### There are three MC1 variants available:

- MC1-20: for controlling brushless EC servomotors (48 V)
- MC1-40: for controlling brushless EC servomotors (310 V)

## Ordering information

MC 1-20 (including PAL-PC)	Part no.: <b>381518 0020</b>
MC 1-40 (including PAL-PC)	Part no.: <b>381518 0040</b>
Motor leads MC 1-20	Part no.: <b>392760 xxxx*</b>
Motor leads MC 1-40	Part no.: <b>392307 xxxx*</b>
Encoder lead	Part no.: <b>392740 xxxx*</b>

\* Leads available in different lengths,  
e.g.: 0100 = 1 m / 0150 = 1.5 m / 0200 = 2 m ... / 1000 = 10 m

## Features

### MC1-20

- for controlling brushless servomotors with an intermediate circuit voltage of 48 V DC
- analysis of Hall signals
- setup program "AcSetup"

### MC1-40

- for controlling brushless servomotors with an intermediate circuit voltage of 310V DC
- analysis of Hall signals
- setup program "AcSetup"

## Common features

- max. output power 500 W (MC1-20)
- 32-bit high performance RISC processor with 256 kB Flash memory
- user program in CNC mode for up to 650 commands
- processing of the program in CNC or DNC mode
- programming with PAL-PC (CNC and CNC mode), @-format (CNC mode), ProNC, Remote (DNC mode)
- LC display with 4 lines, each with 20 characters (freely programmable)
- additional control signals (Start, Stop) adaptable
- connection for incremental encoder
- 6(8) signal inputs (24 V DC)
- 8 relay outputs (24 V DC/700 mA)
- stop category 0 in accordance with EN60204
- emergency shutdown circuit via plug in higher level safety circuit integrable
- broadband mains supply:
  - 110...250 V AC, 50..60 Hz (MC1-20)
  - 250 V AC, 50Hz (MC1-40)
- bench casing  
W 204 × H 149 × D286

## Scope of delivery

- controller
- mating plug (I/O, pulse, remote)
- serial interface lead (SubD9 - RJ 45)
- 230V AC mains lead
- PAL-PC software CD
- operating instructions
- programming instructions

Technical specifications subject to change.

# Power unit

## Multiple axis controller

# iPU-DC/iPU-EC



Figure:  
Power unit iPU as  
bench version and with 19" housing

### Features

- drive controller for up to four brush or brushless DC servo motors
- NC control via CANopen field bus
- iMD10/iMD20 final output stages
  - 4-quadrant drive controller
  - analysis for incremental encoder
  - rest state monitoring
  - over- and undervoltage protection, overtemperature protection, short-circuit proof
- door controller / hood controller
- connection for external control signals, (EMERGENCY SHUTDOWN, START, STOP) for integration in higher level safety circuits
- connection for milling spindle (100 -230V AC)
- 0 .. 10V output for external frequency converter for speed-controlled main spindle
- front-sided control elements (optionally, installed in the rear)
- two alternative casings
- programming/operation
  - Remote (optional: ProNC)

### General

The **iPU power units** are powerful drive controllers for up to four linear or circular axes with brush or brushless motors. The compact controller integrates all necessary controller components, which are needed to solve a wide range of automation tasks. These range from iMD10 or iMD20 final output stages through the I/O module to safety control and power electronics.

As its interface for NC control, the **iPU power unit** has a CANopen interface at the back of the housing, which works according to the DS301 bus protocol and DS402. By using the optional CAN PCI board iCC 10 or a iPC series control computer, the controller can control interpolation (linear, circular, helical) of all four axes as well as track processing.

The final output stages (iMD10 or iMD20) also have automatic jerk limitations and rest state monitoring. The control elements integrated in the front of the housing, such as EMERGENCY SHUTDOWN, START or STOP enable convenient operation.

### Technical specification

- broadband mains supply
  - 115 V AC / 230 V AC, 50..60 Hz
- switching power supply 1000 W / 48 V
- final output stages iMD10 / iMD20
  - Power supply: 24 - 80 V DC
  - Peak / nominal current: 25 A / 12 A
- inputs/outputs
  - 4 digital inputs (24 V DC / 8 mA)
  - 8 digital outputs (24 V DC / 350 mA)
  - 1 relay output (230 V AC, max. 6 A)
  - 1 analog output (0 - 10 V)
- safety controller
  - up to safety category 3
  - door circuit and spindle control
- RJ 45 CANopen interface
- versions:
  - bench housing  
W 475 x H 410 x D 187.5 mm
  - 19" housing  
W 482.5 x H 410 x T 175.5 mm

### Ordering information

3 5 3 0 0 0 X 0 X X

#### Number of axes

- 2 = 2 axes
- 3 = 3 axes
- 4 = 4 axes

#### Versions

- 1 = 19" housing
- 2 = Bench housing

#### Drive controller

- 1 = iMD 10 (brush DC servomotors)
- 2 = iMD 20 (brushless EC servomotors)

### Accessories

Motor lead M23 plug - M23 socket

Encoder lead SubD15 plug - SubD15 socket

CAN PCI board iCC 10 (single channel)  
CAN PCI board iCC 20 (2 channels)  
Controller software - Remote  
ProNC control software

Part no.: **392759 0300** (3m)  
Part no.: **392759 0500** (5m)  
Part no.: **392740 0300** (3m)  
Part no.: **392740 0500** (5m)  
Part no.: **320310**  
Part no.: **320311**  
Part no.: **Z12-334500**  
Part no.: **Z11-333500**

### Scope of delivery

- controller
- mating plug (I/O, pulse, remote)
- CAN bus lead (RJ45, patch lead)
- 230 V AC mains lead
- operating instructions

Technical specifications subject to change.

# Multiple axis controller

## iMD multiple axis controller for isel linear units

# iCU-DC / iCU-EC



iCU-DC  
Front view

iCU-DC  
Rear view

### Features

- drive controller for up to 6 brush or brushless DC servo motors
- NC control via CANopen field bus
- iMD10/iMD20 final output stages
  - 4-quadrant drive controller
  - analysis for incremental encoder
  - rest state monitoring
  - over- and undervoltage protection,
  - overtemperature protection, short-circuit proof
- door control / hood control
- external emergency cut-out for integration into higher level safety circuits
- connection for external control signals (START, STOP, RESET) via signal inputs
- control computer connections:
  - VGA, 4 x USB (2 x front, 2 x rear),
  - RJ45 Ethernet (100 Mbit/s)
- connection for milling spindle (100 -230V AC)
- 0 ...10 V output for external frequency converter for speed-controlled main spindle
- front-sided control elements
- industrial control computer based on Windows® with
  - CANopen PCI board
  - driver software for CNC control
- programming/Operation
  - Remote (optional: ProNC)

### General

The **CAN controllers** of the **iCU-DC** and **iCU-EC** series are compact, high-performance drive controllers for 2 - 6 DC servomotors and are offered at an optimal price / performance ratio.

The bench housing integrates all control components needed to solve a wide variety of automation tasks, ranging from the final stage via the I/O assembly to the safety controller.

The control computer has an integrated CANopen PCI card interface serving as CAN Master for the drive controller and I/O components. External upgrades are also possible, up to 128 CAN nodes. The connecting points at the rear of the control computer facilitate easy connection to (for example) a monitor. Peripherals such as a mouse and keyboard can be connected at the USB interfaces provided. LAN connection allows integration into an existing network and can be used for remote servicing.

The NC control core facilitates the interpolation of up to 6 axes (linear, circular, helical) as well as Online and Look Ahead machining. When using the ProNC software, individual axes can be controlled as handling axes (in addition to the interpolating axes).

All final stages have automatic jerk limitation and rest state monitoring (up to safety category 3).

### Technical specification

- broadband mains supply
  - 115 V AC / 230 V AC, 50...60 Hz
- switching power supply 1000 W / 48 V
- iMD10/iMD20 final output stages
  - Power supply: 24...80 V DC
  - Peak / nominal current: 25 A / 12 A
- input/output of CAN E/A module
  - 4 digital inputs, 8 digital outputs
  - 1 relay output (230V AC, max. 6 A)
  - 1 analog output (not required with frequency convertor option)
- CAN safety circuit module
  - up to safety category 3
  - door circuit control
  - spindle control
- bench casing
  - W 630 x H 230 x T 400 mm
- options:
  - frequency converter for iSA500 - iSA2200
  - additional CAN I/O module (16 x inputs, 16 x outputs)

### Ordering information

3 5 4 0 1 2 X 0 X 0

#### Number of axes

- 2 = 2 axes
- 3 = 3 axes
- 4 = 4 axes
- 5 = 5 axes
- 6 = 6 axes

#### Versions

- 1 = iCU DC\* (brush-type DC servomotors)
- 2 = iCU EC\* (brushless EC servomotors)

### Accessories

Motor lead M23 pin - M23 socket  
Part no.: **392759 0300** (3m)  
Part no.: **392759 0500** (5m)

Encoder lead SubD 15 plug - SubD15 socket  
Part no.: **392740 0300** (3m)  
Part no.: **392740 0500** (5m)

### Scope of delivery

- controller
- mating plug (I/O, pulse, remote)
- 230V AC mains lead
- operating and programming instructions

Technical specifications subject to change.

# CAN-CNC controller

Example of a topology with the isel-CAN-CNC controller

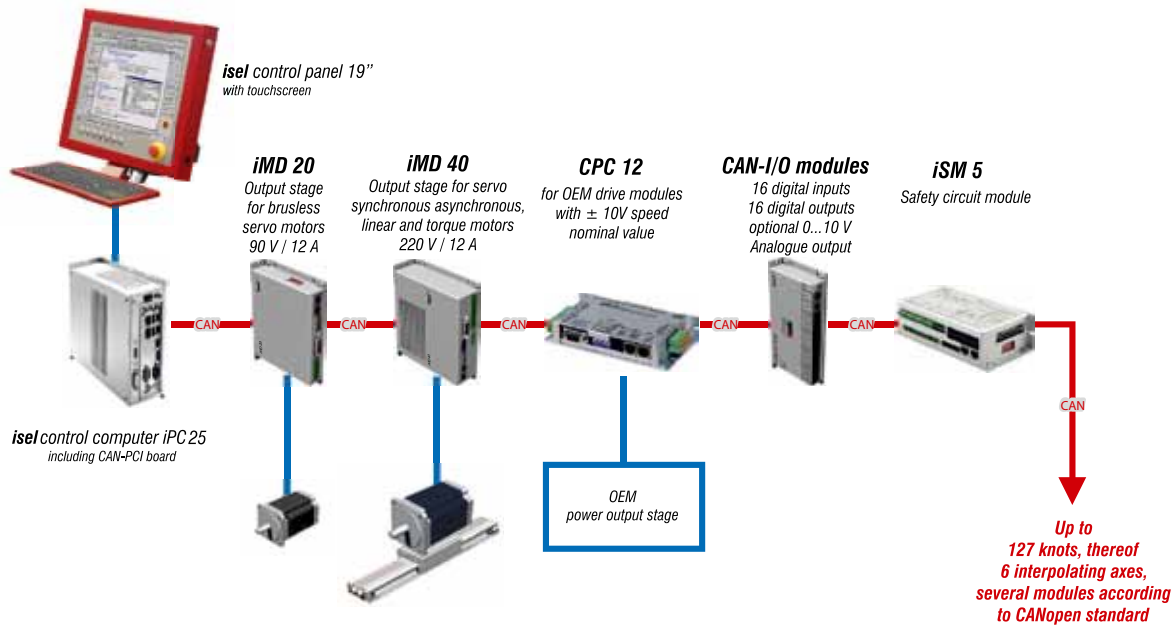

With consequent use of the CiA's (CAN in automation) **CANopen** standards, isel Germany delivers a high quality PC-based **CAN-CNC controller** for intelligent positioning/drive units and I/O modules.

The **CAN-CNC controller** supports interpolation operation (linear, circular and helical) of up to six positioning drives per machine and up to 127 handling axes and CAN modules.

The high time demands of a CNC controller are guaranteed by a WDM driver developed by isel. An additional real time operating system for Windows will be unnecessary. This guarantees compatibility with future Windows versions

The CAN controller is a pure software solution for PCs with Windows 2000/XP/VISTA/Win7 (32/64 bit). The CANopen PCI boards iCC 10/20 also act as an interface.

Owing to the features provided, the **CAN-CNC controller** is equally suited for all machining tasks, such as milling, engraving, drilling, turning, water jet and laser cutting, as well as for applications in automation systems.

For this purpose, **ProNC** provides a universal programming environment.

## Features

- machine control to the **CANopen** standard as a pure software solution for PCs with Windows 2000/XP/VISTA/Win7 (32/64 bit)
- CiA-Standard, DS 301, DSP 401, DSP 402
- supports up to six positioning axes and 127 handling axes and CAN modules.
- look ahead track processing with a freely definable number of movement elements, which the controller processes while looking ahead.
- jerk limitation for elimination of mechanical vibrations
- upstream speed control for highly dynamic and lag error-free machining
- software tools for setting and optimising motor final stages/positioning modules
- interfaces for PC:
  - CANopen PCI board iCC 10 (single channel)
  - CAN bus 1
  - CANopen PCI board iCC 20 (two channels)
  - CAN buses 1 and 2

Technical specifications subject to change.

# software



betrieben by PC 3.0



Block 10 (H=...)

Zoom=+16.7112, -T:5099, -O:27, 1153,499



ire

## SOFTWARE

Software and  
control organization ..... D-2

### CAD / CAM-Software

isy-CAM 2.8 ..... D-4

### Interpreter software

Remote ..... D-6

### Programming software

ProNC ..... D-7

# Software and controller organisation

- CAD/CAM Software
- Operating and programming software (text format)
- Operating and programming software (graphics format)
- Interpreter software
- DLL concept
- Hardware

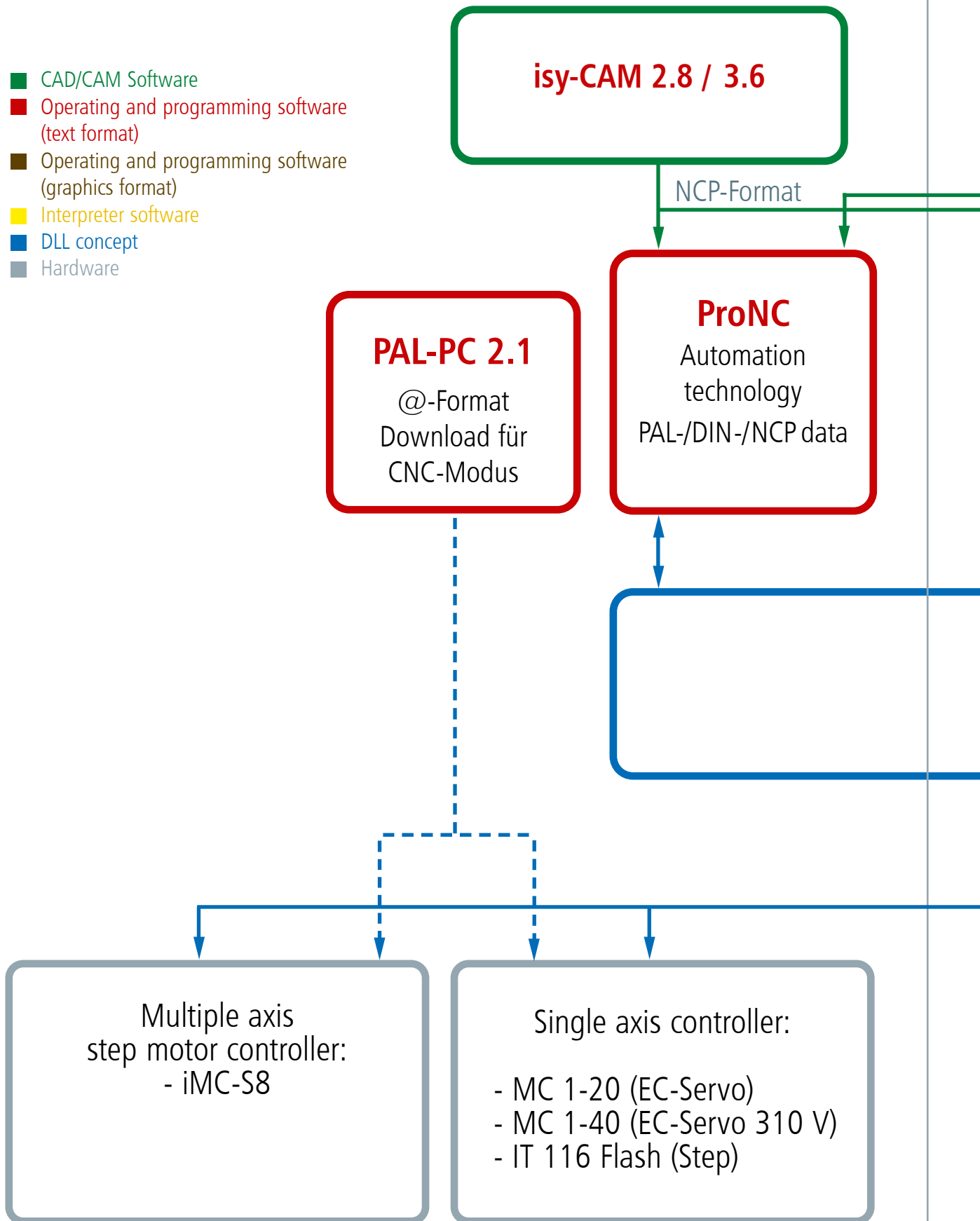



# Software and controller organisation

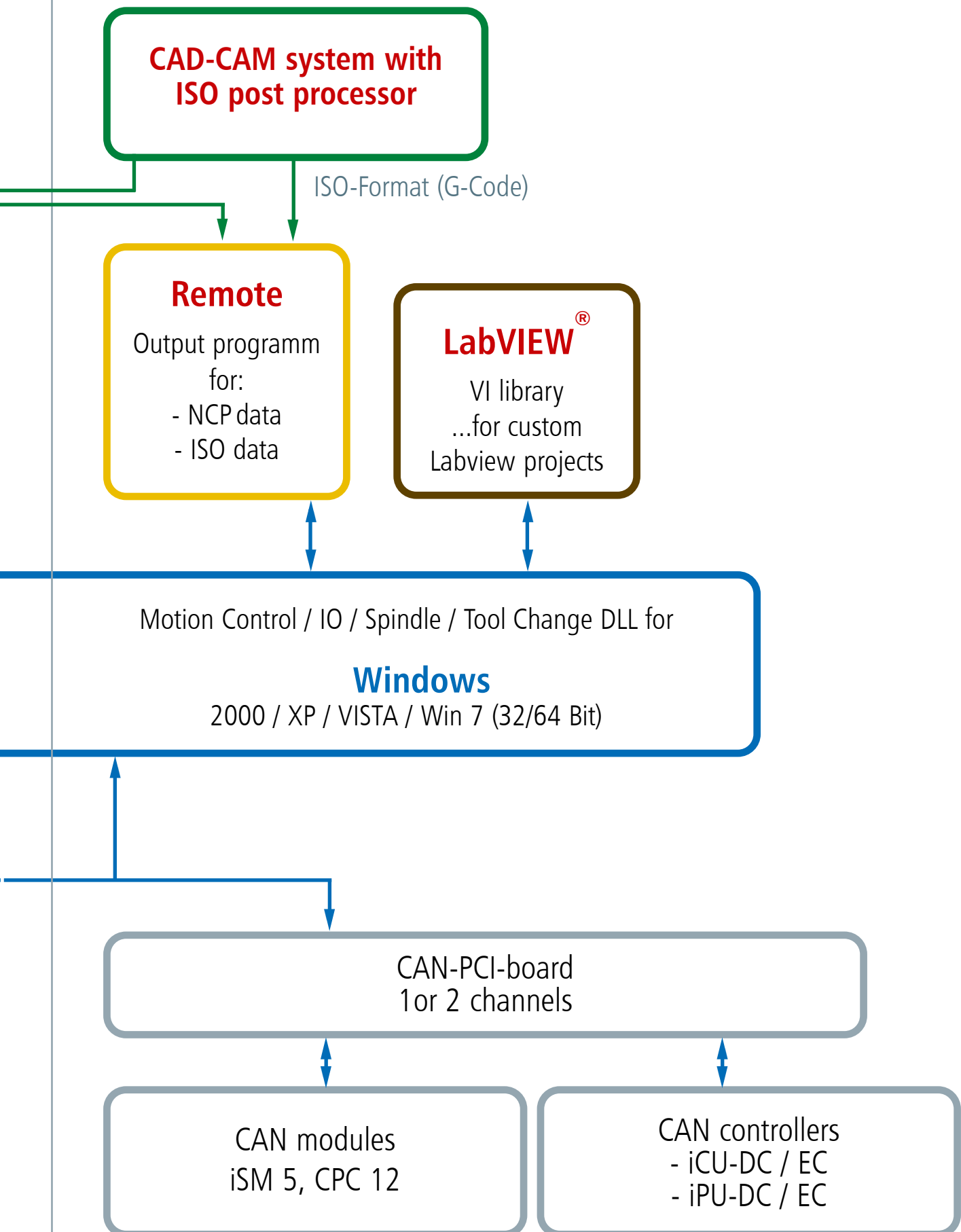

# isy-CAM 2.8 and 3.6

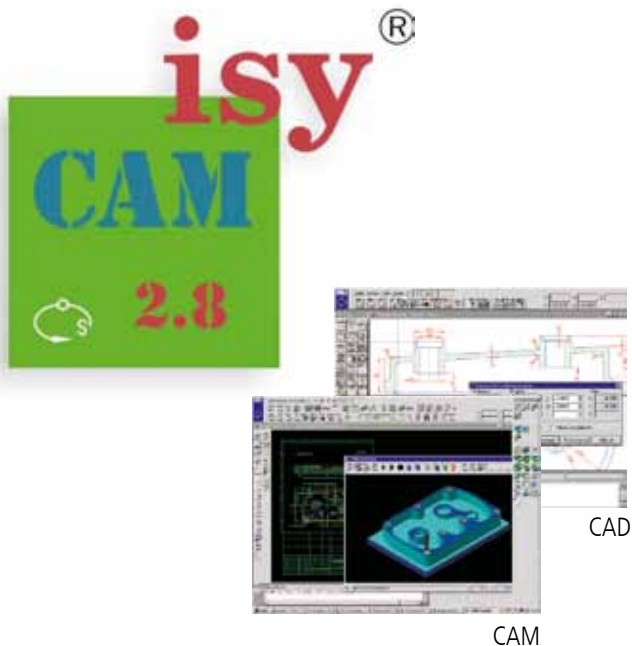

## Features isy-CAM 2.8

- CAD functionality (without volume modeller)
- works with Win XP, Windows 7 and 8, 32-/64-bit version
- import: DXF / EPS / AI / 3D STL data  
export: NCP format
- proven CAM strategies
- for drilling / contour and pocket milling
- engraving with thinning
- engraving on cylinder surface with 4th axis
- 3D roughing and finishing of STL data (e.g. 3D scanning models)
- direct call of REMOTE out of isy-CAM

## Features isy-CAM 3.6

- advanced mesh manipulation
- 32-/64-bit version
- Hybrid milling (steep and flat areas in one step)
- trochoidal milling
- revised residual material detection and handling
- multi-sided machining (3+2 axis, hired milling)
- extendable to 5 simultaneous-moveable axes

## Ordering data

### isy CAM 2.8

Part-no.	Description
Z13-337070	isyCAM2.8, 2.5D CAD/CAM Software, including 3D STL manipulation, PC bound, without training
Z13-337070 0001	isyCAM2.8, 2.5D CAD/CAM Software, requirement: registered 2.5/3.0 version, including 3D STL manipulation, PC bound, without training
Z13-337070 0002	isyCAM2.8, 2.5D CAD/CAM Software, including 3D STL manipulation, PC bound, with training at isel
Z13-337070 0003	isyCAM2.8, 2.5D CAD/CAM second license, PC bound, without training

### isy CAM 3.6

Part-no.	Description
Z13-337071	isyCAM3.6, 3+2 axis, including NCP - PPRO, PC bound, including training for 1 person at isel
Z13-337071 0001	Update isyCAM 2.0 / 2.5 / 2.5plus to isyCAM 3.6, 3+2 axis, including NCP - PPRO, PC bound, without training
Z13-337071 0002	Update isyCAM 3.0 / 3.2 to isyCAM 3.6, 3+2 axis, including NCP - PPRO, PC bound, without training
Z13-337071 0003	Update isyCAM 3.0 / 3.2 to isyCAM 3.6, 3+2 axis, including NCP - PPRO, PC bound, without training
Z13-337071 0004	Update isyCAM 2.8 to isyCAM 3.6, 3+2 axis, including NCP - PPRO, PC bound, without training
Z13-337071 0005	Update isyCAM 3.6 second license, PC bound, without training
Z13-337071 0006	Exchange-Package 3.6 (IGES, VDA, STEP)
Z13-337071 0007	Update Exchange-Package 2.0 to 3.6 (IGES, VDA, STEP)
Z13-337071 0008	Update Exchange-Package 3.0 to 3.6 (IGES, VDA, STEP)
Z13-337071 0009	Update Exchange-Package 3.2 and 3.4 to 3.6 (IGES, VDA, STEP)

## Common features

- multi-core support
- dynamic rotatable simulation
- freely definable line styles and colors
- integrated online help, configurable user interface
- parallel and independent work on several drawings
- geometric elements such as points, lines, ellipses, circles, curves (polygons, splines, bezier curves, NURBS), polygons etc.
- direct use of the Windows fonts
- professional functions for editing figures and texts
- hatching, user-defined hatch patterns
- automatic functions for positioning and aligning
- contours sketching and change interactively
- numeric input methods for absolute, relative and polar coordinates
- extensive DIN / ISO-compliant measuring- and dimensioning functions
- trimming, cutting and drawing curves and conversions of different geometrical types
- geometrical manipulation by moving and copying as translation, rotation, scaling, mirroring
- intelligent object snap
- optimal control of the calculated NCP data through integrated online simulation of tool paths
- production of processing data for all typical 2D and 2.5D machining tasks
- output format: NCP format

## CAD/CAM supplier

The following CAD/CAM manufacturers offer postprocessors for our machine control systems. (isel NCP-Format, DIN/ISO G-Code)











Other are:

- Galaad 3
- madCam
- DeskProto
- FilouNC
- ConstruCAM-3D
- Editask
- Inventor HSM

And much more.

# Remote

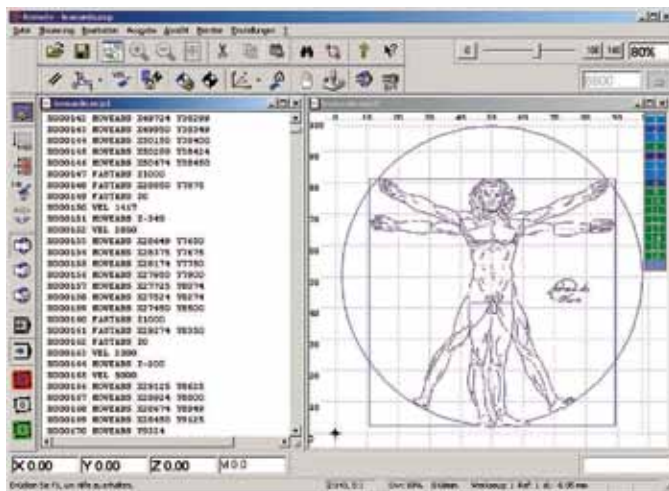

## Control software for Windows

### General

**Remote** is a universal control program for outputting files for machining methods milling, drilling, adhesive bonding, engraving, applying and water jet cutting or laser cutting/welding.

Supported file formats are the isel-specific NCP format (ASCII file with machining data generated by a CAM post-processor, the isel-specific CNC format (ASCII files in an expanded format for universal use in the process automation area, generated by ProNC) and the G-code format to DIN 66025.

**Remote** is used first and foremost for controlling CNC machines operating different tasks and processes, which is why flexibility is a key feature of the program. A large choice of options allows easy adaptation to current requirements in each case.

### Features

- support for digital joysticks
- "Fast file selection" control panel for serial production
- milling/multiple output with movements
- graphic depiction of the processing file with zero point and dimensions

#### isel-NCP, DIN66025/G-code file formats

- linear and circular interpolation, helical interpolation, drilling cycles
- access to digital and analogue inputs and outputs
- when using a CAN controller: "On-the-fly" input/output (without stopping the movement) for metering applications
- message window, messages in the status line, time delay, input of variable values
- definition and use of machine positions (tool zero point, park position, home position, etc.)

#### Additional features for the isel-CNC file format (ProNC output format)

- repeating loops, counting loops, unconditional and conditional branches
- arithmetic and trigonometric functions
- sub-program systems
- real and symbol chain variables
- loading and storing process variables
- access to user-specific expansions, option to call up user software

### Ordering information

Part no.: **Z12-334500**

Remote - software for CAN-CNC controllers (Windows)

### Features

- runs with Windows operating systems (Windows 2000, XP, Vista)
- compatible with previous software versions
- processing of DIN66025 (G-code) file formats, NCP or CNC
- immediate processing without conversion, File translation or conversion
- integrated text editor with numerous features for rapid corrections to the present NC program
- use of up to 6 interpolating axes (Cartesian coordinates system and 3 auxiliary axes)
- look-ahead track processing with CAN controller
- managing a milling spindle
- 2 I/O units can be used (max. 64 inputs, 64 outputs)
- signalling inputs and outputs for process synchronisation
- manual axis movement with joystick, keyboard and mouse
- incremental processing and system monitoring for commissioning
- configurable interface for user-friendly operation, serial production, handshake with master PLC, etc.
- control panel for movement control, input/output, spindle and tool change with buttons
- control panel for max. 6 handling axes independently of the interpolating axes
- available in various languages (German, English, French, Magyar)

# ProNC

## Process automation software for Windows

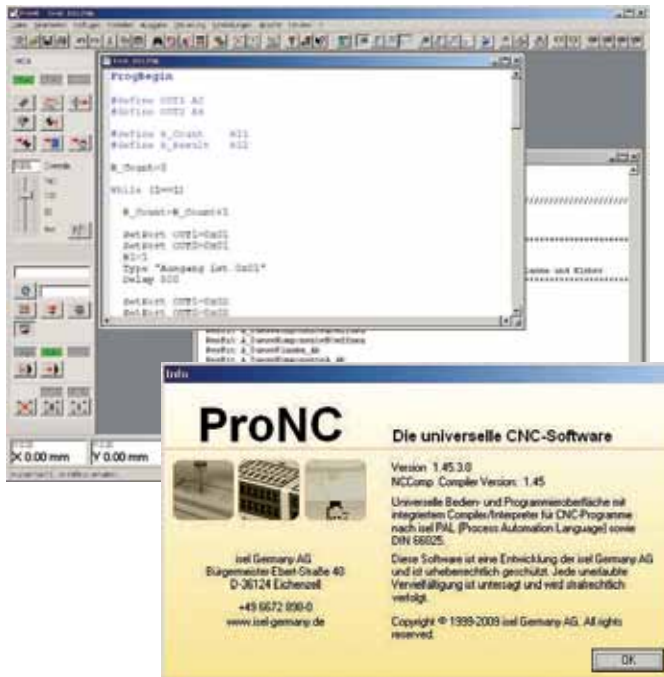

### General

The basis of any automation solution is a powerful software that enables implementation of practical solutions for existing tasks quickly and conveniently. In these cases, the operating and programming interface ProNC provides an ideal solution.

- ProNC** runs with the Windows 2000, XP and Vista operating systems.
- ProNC** is available for a variety of control systems and controllers from isel
- ProNC** applications can be produced to isel-PAL or DIN66025

**ProNC** is outstandingly suited to automation solutions in the milling, drilling, metering, installation, handling, loading and quality control fields, in which application programs are produced mainly in text format, using teach-in-features and the integration of contour data sets (e. g. NCP format).

### Features

- path commands for relative and absolute positioning of the interpolating axes
- programming of additional axes in handling mode
- circular interpolation, helical interpolation, drilling cycles
- repeating loops, counting loops, unconditional and conditional branches
- various mathematical and trigonometric functions
- sub-program systems, symbolic variables
- real and symbol chain variables
- message window, messages in the status line
- loading and storing process variables
- access to digital and analogue inputs and outputs
- "On-the-fly" input/output (without stopping the movement) for metering applications
- access to user-specific extension DLLs
- convenient support for debugging (interruption points, monitoring of status and variable)

### Ordering information

Part no.: **Z11-333500**

ProNC - software for CAN-CNC controllers (Windows)

### Features

- programming to DIN66025 (G-codes) or isel-PAL
- compatible with previous software versions (ProDIN, ProPAL)
- integrated text editor with numerous features for rapid and efficient source code processing
- Import of geometric data (NCP, e.g. from isy-CAD/CAM)
- use of up to 6 interpolating and up to 6 handling axes (with CAN controller)
- look-ahead track processing with CAN controller
- up to 4 spindle motors can be used
- up to 4 I/O units can be used (max. 64 inputs, 64 outputs)
- signalling inputs and outputs for process synchronisation
- teach-in-with joystick, keyboard and mouse
- offline programming with simulation modules
- incremental processing, hold points and system monitoring for commissioning
- individually expandable with software libraries
- control panels for movement control, input/output, spindle and tool change with buttons
- control panel for max. 6 handling axes independent of the interpolating axes
- available in german and english

Training courses and application solutions to order.

# system

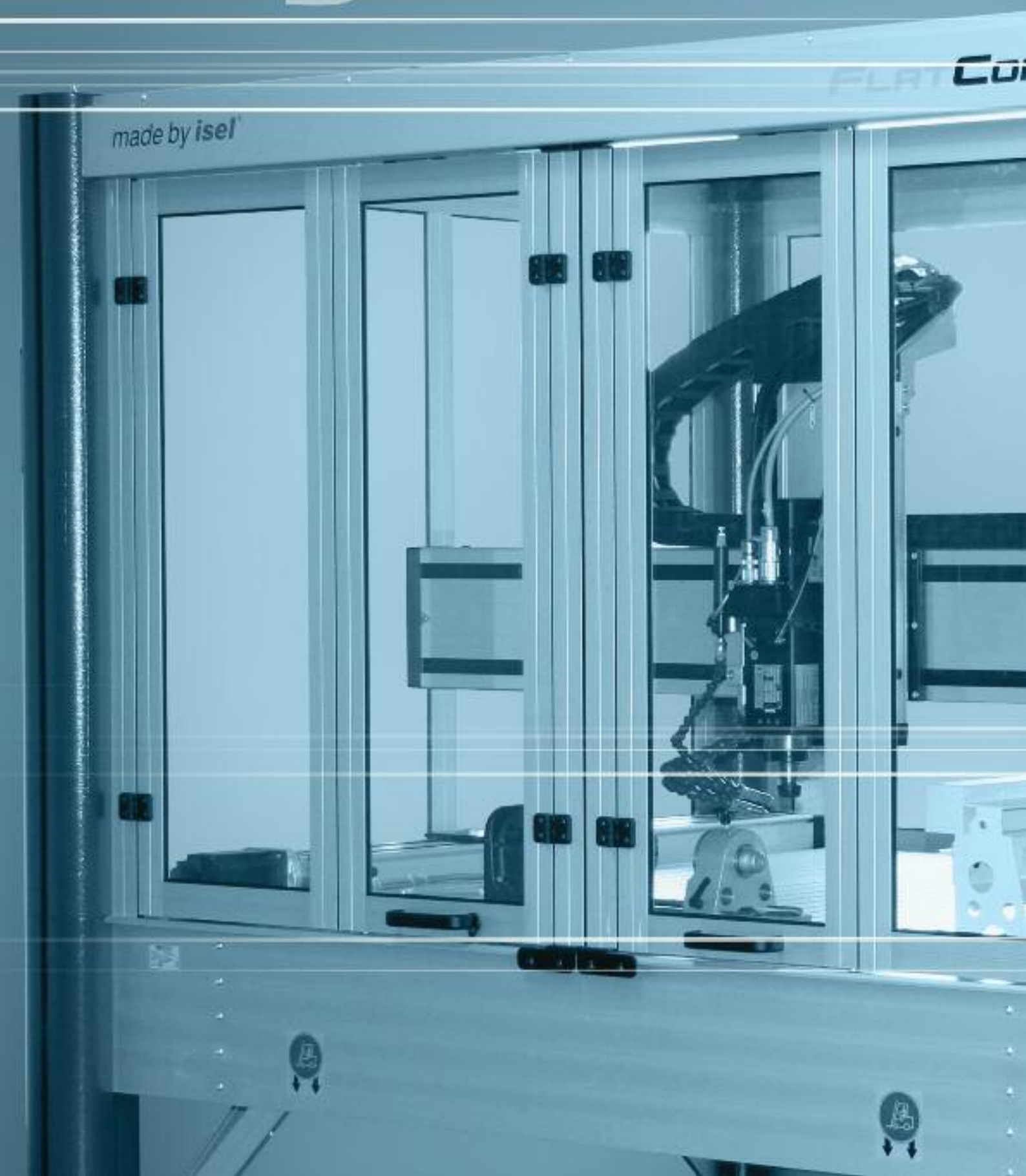

# ms



## SYSTEMS

CNC machines ..... E-8  
with step motor or servo motor drive

Machine configuration ..... E-20  
Accessories ..... E-22

Robotics ..... E-48

# The CNC machines from isel Germany AG

furnishes plant manufacturers and users a fit occasion.



Efficient mass production in the machinery and plant sector is desirable for each manufacturer, however not invariably realizable in reference to the increasingly specialized areas of application of the customers. We, the isel Germany AG, have set ourselves the claim to successfully realize your requirements with our machines - be it in the form of a plug-and-play version or as an open system in various sizes, in which you can integrate your application easily later.

Modular structure with light frame construction, isel linear axes, precision steel shafts and patented linear bearings have proved themselves over the years and are subject to continuous optimization. Our clearance-free ball screw drives with hardened and polished ball screw spindles in different diameters and pitches, step and servo motor operation or direct drive with linear and torque motors allows you to tailor your system technically to your needs - a scope which sometimes hosts price advantages.

In addition to established programming and interpreter software, you can refer the 3D CAD / CAM software isy 2.8 and 3.6, for which we also offer individual training at our plant or at your place. Our slogan "From Components to Systems" underlines how important it is for us, to know our machines to the smallest detail and give you the opportunity to purchase all from one source.





# The CNC machines from isel Germany AG

A wide range of accessories such as speed-controlled spindle motors, tool changing stations in various designs, patented tool cooling and handling systems from our area isel Robotics complete our range of products. In the new development and manufacture of our systems, security plays an important role. All systems are subject to the Machinery Directive 2006/42EG.

Do you have questions  
about your application?  
Contact us!

Our trained staff from the technical sales can advise you and submit a detailed quotation on request. Planning, realization and completion of your project in the form of design and manufacture of special machines belongs to the same extent to our offered services such as a customer-oriented after-sales service. Feel free to contact us!

phone: **+49 (0) 6659 / 981 790**  
or [sales@isel.com](mailto:sales@isel.com)



Special design of the **FlatCom XL**  
for milling of foams for the orthopedic industry

## Leasing / Financing



Our financing partners at MMV Leasing know how important a quick and professional completion of financing agreements is for our customers. We work closely with you to get the right financial package to suit your individual business objectives. Whether you opt for a new model or a used machine from isel: together we will draw up the finance quote that suits you.

### Your benefits

- longstanding experience with top financiers
- short response time with secure and quick credit assessment

# Life Cycle Service

... to ensure, that you can use your CNC machine every day without any worries

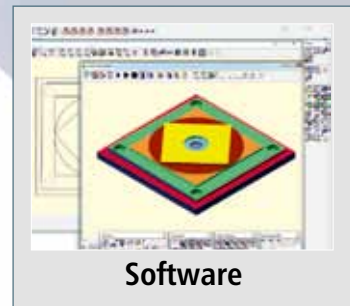
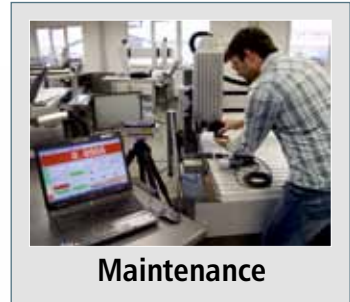

# Life Cycle Service



Webshop



Service



Spare parts



Retrofitting



Training



# Maintenance packages



## Hotline

You can reach us from

Monday – Friday between 7:30 a.m. and 04:30 p.m.,  
Saturday / Sunday every day from 9:00 a.m. til 3:00 p.m.

as well as for the free maintenance via Internet (TeamViewer)

Monday – Friday between 7:30 a.m. and 04:30 p.m.  
Saturday / Sunday every day from 9:00 a.m. til 3:00 p.m.

Similarly, a remote maintenance by our trained employees and over the Internet (TeamViewer) is possible.

Nobody can afford a production stoppage and we ensure the reliability of your isel product at all times. Regular maintenance by our highly qualified service technicians guarantees the greatest precision and reliability – for the lifetime of the machine. We maintain your machine in a professional, safe and reliable manner. Ask your isel contact if you are interested in a maintenance package.

The maintenance packages are available in the following versions:

	STANDARD	COMFORT	EXCELENT
<b>services included</b>	1x annual maintenance, inspection and execution of small repairs	2x annual maintenance, inspection and execution of small repairs	
	1 x driving	2 x driving	
	1 x working time during the annual maintenance	2 x working time during the annual maintenance	
	1 x cleaning of the mechanical components including lubrication of the axes	2 x cleaning of the mechanical components including lubrication of the axes	
	1 x update of the firmware in the controllers and of the software	2 x update of the firmware in the controllers and of the software	
	1 x visual inspection and, where appropriate, renewal of the safety warnings and other labels in accordance with the Machinery Directive	2 x visual inspection and, where appropriate, renewal of the safety warnings and other labels in accordance with the Machinery Directive	
	1 x testing, adjustment of the belt tension and measuring of the system	2 x testing, adjustment of the belt tension and measuring of the system	
	--	10% discount of spare parts and other work	15% discount of spare parts and other work
	€ 450,- drive flat-rate (individual)	€ 450,- drive flat-rate per maintenance (individual)	
	Service within 72 hours from Monday - Friday, except bridging days and public holidays (in Hesse and Thuringia)	Service within 48 hours from Monday - Friday, except bridging days and public holidays (in Hesse and Thuringia)	Service within 24 hours from Monday - Friday, except bridging days and public holidays (in Hesse and Thuringia)
<b>Item-No.:</b>	<b>991000 0039</b>	<b>991000 0040</b>	<b>991000 0041</b>

# CNC machines

## Overview

CNC machine

E-8

OverHead Gantry



CNC machine

E-10

FlatCom XL



CNC machine

E-12

EuroMod



CNC desktop machines  
series ICP / ICV

E-14



Flat bed and portal units

E-18



Machine configuration

E-20

Accessories

E-22

# CNC machine

with servo motor drive

**OverHead**<sup>®</sup>
**UNSER TOP-SELLER!**
**Features**

- Compact footprint size
- Free floor standing design
- Large open machining area
- High Z-axis clearance for deep tool machining



Interesting application videos can be found on our YouTube channel. Just take a look!

**We offer FINANCING!**

**OverHead M40**  
with control panel iOP-19-TFT

## Technical specifications

	OverHead M20	OverHead M30	OverHead M40	OverHead M50	OverHead M60
<b>Processing areas X/Y/Z [mm]</b>	710 / 610 / 310	710 / 910 / 310	1210 / 910 / 310	1210 / 1410 / 310	1510 / 1710 / 310
<b>Bench clamping area WxD [mm]</b>	1100 x 1000	1100 x 1300	1600 x 1300	1600 x 1800	1750 x 2000
<b>Gap [mm]</b>	340 (590)				
<b>Dimensions WxDxH [mm]</b>	1400 x 1200 x 1960	1400 x 1500 x 1960	1900 x 1500 x 1960	1900 x 2000 x 1960	2245 x 2400 x 1970
<b>Processing speed X/Y/Z [mm/s]</b>	250				
<b>Drive motors</b>	EC servo motors				
<b>Drive elements X/Y/Z</b>	Recirculation ball screws 16 x 10 / 16 x 10 / 16 x 5 mm, adjustable for no play				
<b>Controller</b>	iMD CAN controller with 4 drive controllers, expandable to 12 axes (max. 6 interpolated & 6 handling axes), PC, I/O module, safety circuit with rest state monitoring, power supply unit 48 V / 1,000 W				
<b>Operation</b>	control panel iOP-19-TFT				
<b>Weight (kg)</b>	appr. 525 kg	appr. 600 kg	appr. . 700 kg	appr. 800 kg	appr. 1100 kg
<b>Software</b>	Windows, WinRemote (optional: ProNC)				
<b>Connection values</b>	400 V / 16 A				
<b>Part-no.</b>	<b>276223 56165</b>	<b>276233 56165</b>	<b>276243 56165</b>	<b>276253 56165</b>	<b>276263 56165</b>

# CNC machine

## with servo motor drive

**OverHead**<sup>®</sup>

### Features

- twin Y-axis gantry fully synchronised with Software ProNC
- CAN-bus control system with brushless servo motors for all axes
- T-slot table top for easy clamping of workpieces and accessories
- gantry clearance options from 340mm to 590mm
- maximum spindle motor size iSA 2200
- linear motion upto 250mm/sec.
- control panel iOP-19-TFT
- control PC iPC 25 including PCI card Win 7/64 bit

### Areas of application

- machining
  - testing and measuring
  - glue dispensing
- For the machining of:
- light metals
  - non-ferrous metals (brass, bronze etc...)
  - CFRP
  - ceramic
  - plastics
  - wood

### Options

- cooling spray device
- blade tray
- tool length sensor
- spindle motors (up to iSA2200 applicable)
- round changing systems SK 11 and SK 20
- linear changing systems SK 11 and SK 20
- 4th axis with tailstock unit
- 4th + 5th axis as rotary tilting unit
- LED-lighting

Overview machine configuration  
see page E-21

### Dimensioned drawings

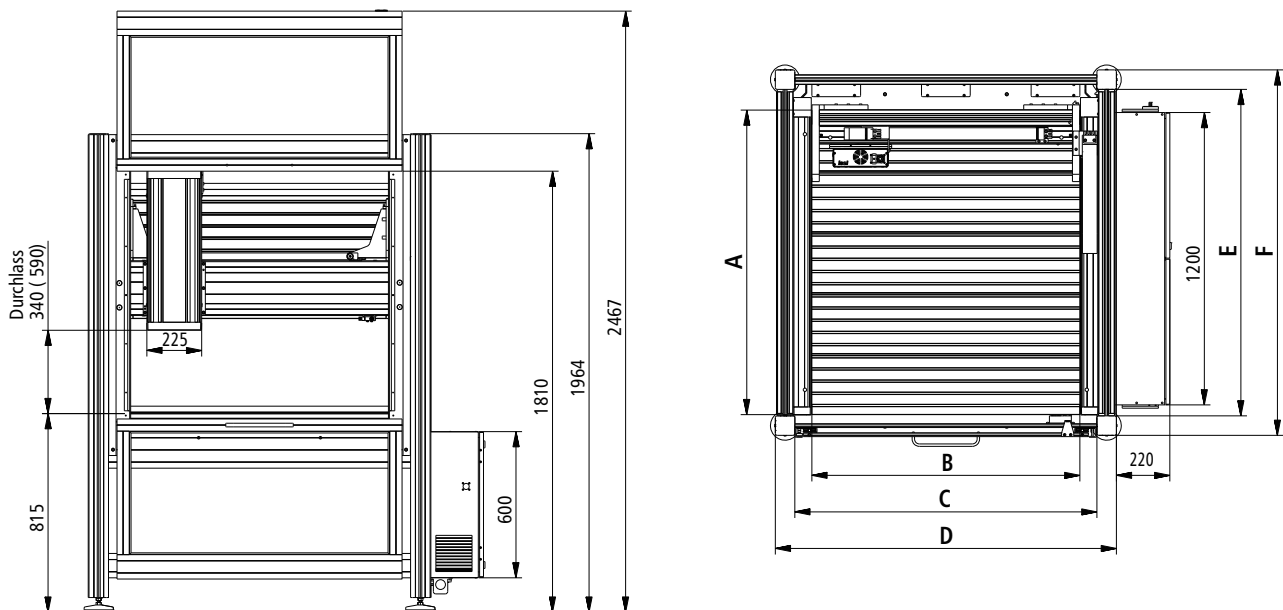

	A	B	C	D	E	F
<b>Gantry OverHead M20</b>	1000	1100	1240	1400	1040	1200
<b>Gantry OverHead M30</b>	1250	1100	1240	1400	1340	1500
<b>Gantry OverHead M40</b>	1250	1600	1740	1900	1340	1500
<b>Gantry OverHead M50</b>	1750	1600	1740	1900	1840	2000
<b>Gantry OverHead M60</b>	2000	1750	2150	2400	1995	2245

Technical specifications subject to change.

# CNC machine

with servo motor drive

# FLATCom® XL



## Features

- Windows-based software
- Gantry drive
- Mobile portal, fixed bench



FlatCom XL with control pult iOP-19

Interesting application videos can be found on our YouTube channel. Just take a look!

## Technical specifications

	FLATCom® 102/72	FLATCom® 102/112	FLATCom® 142/112	FLATCom® 142/162	FLATCom® 142/252
<b>Processing areas X/Y[mm] *</b>	1,020 / 720	1,020 / 1,120	1,420 / 1,120	1,420 / 1,620	1,420 / 2,520
<b>Z lift [mm]</b>	210 (optional: 410, in each case without processing unit)				
<b>Bench clamping area W x D[mm]</b>	1,125 x 1,300	1,125 x 1,700	1,500 x 1,700	1,500 x 2,200	1,500 x 3,050
<b>Z gap[mm] *</b>	235 (optional 435, in each case without processing unit)				
<b>Dimensions WxDxH[mm]</b>	2,084/1,584/1,990	2,084/1,984/1,990	2,459/1,984/1,990	2,459/2,484/1,990	2,459/3,384/1,990
<b>Processing speed X/Y/Z</b>	max. 250				
<b>Repeat accuracy[mm]</b>	± 0.02				
<b>Drive motors</b>	Servo motors				
	Recirculating ball drive, adjustable for no play				
	iMD CAN controller with 4 drive controllers, expandable to 12 axes (max. 6 interpolated & 6 handling axes), PC, I/O module, safety circuit with rest state monitoring, power supply unit 48V/1000 W				
<b>Operation</b>	Control pult iOP-19-CPU				
<b>Weight[kg]</b>	approx. 550	approx. 600	approx. 700	approx. 800	approx. 1000
<b>Software</b>	Windows, WinRemote (optional: ProNC, isy 2.8)				
<b>Connection values</b>	400 V, 16 A				
<b>Part-no. (Z lift = 210 mm)</b>	<b>276552 0013E</b>	<b>276553 0013E</b>	<b>276554 0013E</b>	<b>276555 0013E</b>	<b>276556 0013E</b>

\* without mounted components on the axes !



# CNC machine

## with servo motor drive

# FLATCom<sup>®</sup> XL

### Features

- portal gap: 235mm optional 435mm (for bigger workpieces)
- maintenance-free servo motors
- particularly suitable for the whopping editing (aluminium, non-ferrous metals, ceramics etc...)
- installation of spindle motors up to 3.6 KW, SK 30 tool holders
- available with or without protective hood
- ideal for multi-shift operation
- control pult iOP-19-CPU
- control PC iPC 25 including PCI card Win 7/64 bit

### Areas of applications

For the machining of:

- light metals
- non-ferrous metals (brass, bronze etc...)
- CFRP
- ceramic
- plastics
- wood

### Options

- PC control console with free PCI plug-ins (for use by external PCI hardware)
- safety light curtain
- milling and engraving spindles
- SK11/SK20 automatic tool change stations
- minimum quantity lubrication or CoolMin cooling system
- vacuum clamping benches
- suction device
- 4th axis e. g. RDH series installation
- version without hood
- maximum 6 interpolated axes + 6 handling axes
- portal gap 435 mm

Overview machine configuration  
see page E-21

### Dimensioned drawings

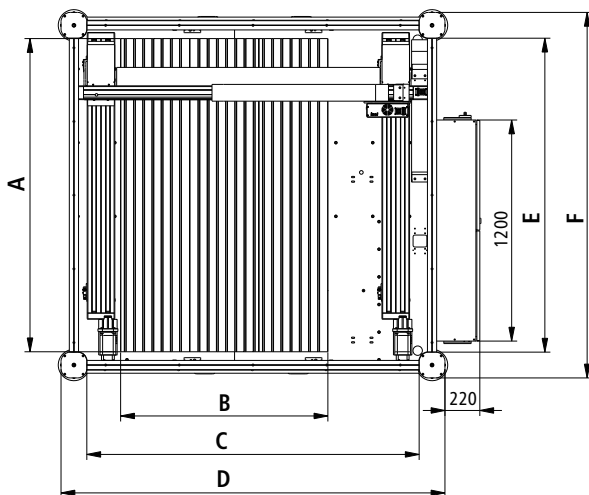
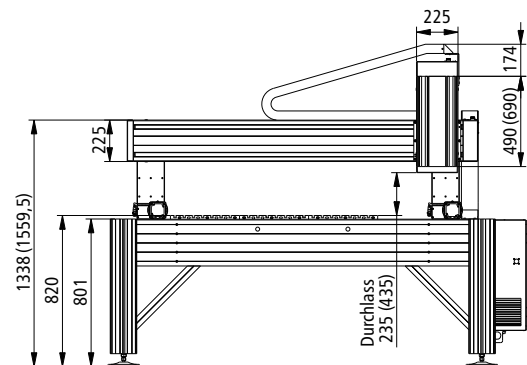
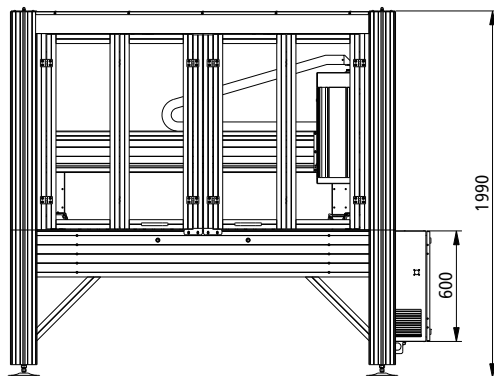

	A	B	C	D	E	F
FlatCom XL 102/72	1,300	1,125	1,804	2,084	1,304	1,584
FlatCom XL 102/112	1,700	1,125	1,804	2,084	1,704	1,984
FlatCom XL 142/112	1,700	1,500	2,179	2,459	1,704	1,984
FlatCom XL 142/162	2,200	1,500	2,179	2,459	2,204	2,484
FlatCom XL 142/252	3,050	1,500	2,179	2,459	3,100	3,380

Technical specifications subject to change.

# CNC machine

with servo motor drive

**EUROMOD®**

## Features

- Space-saving
- fixed portal, moving bench
- also available with gantry drive



Interesting application videos can be found on our YouTube channel. Just take a look!



**EuroMod MP 65**  
with control panel iOP-19-TFT  
and closed sliding door

## Technical specifications

Processing areas X/Y/Z [mm] *	650 / 300 / 250	650 / 450 / 250	1,000 / 650 / 250
Bench clamping area W × D [mm]	900 x 350	900 x 500	1,200 x 700
Gap [mm] *	350		
Dimensions WxDxH [mm]	1,160 x 800 x 1,960	1,160 x 1,110 x 1960	1,480 x 1,510 x 1,960
Processing speed X/Y/Z	max. 250 mm/s		
Repeat accuracy [mm]	± 0.02		
Drive motors	Servo motos		
Drive elements X/Y/Z	Recirculating ball drive, adjustable for no play		
Controller	iMD CAN controller with 3 or 4 drive controllers, expandable to 12 axes (max. 6 interpolated & 6 handling axes), PC, I/O module, safety circuit with rest state monitoring, power supply unit 48V/1000 W		
Operation	Control panel iOP-19-TFT		
Weight (kg)	approx. 275	approx. 300	approx. 400
Software	Windows, WinRemote (optional: ProNC, isy 2.8)		
Connection values	230V, 16A		
Part no.	<b>276133 53655E</b>	<b>276143 53655E</b>	<b>276153 73655E</b>

\* without mounted components on the axes !

# CNC machine

## with servo motor drive

**EUROMOD®**

### Features

- portal gap: 350mm
- maintenance-free servo motors
- maximum spindle motor size up to 1.5 kW
- available with or without protective hood
- ideal for multi-shift operation
- control panel iOP-19-TFT
- control PC iPC 25 including PCI card Win 7/64 bit

### Areas of applications

For the machining of:

- light metals
- plastics
- wood
- foams
- plexiglas

### Options

- PC control console with free PCI plug-ins (for use by external PCI hardware)
- stainless steel keyboard
- safety light curtain
- milling and engraving spindles
- SK11/SK20 automatic tool change stations
- minimum quantity lubrication or CoolMin cooling system
- vacuum clamping benches
- suction device
- 4th axis e. g. RDH series installation
- pneumatic sliding door

Overview machine configuration  
see page E-20

### Dimensioned drawings

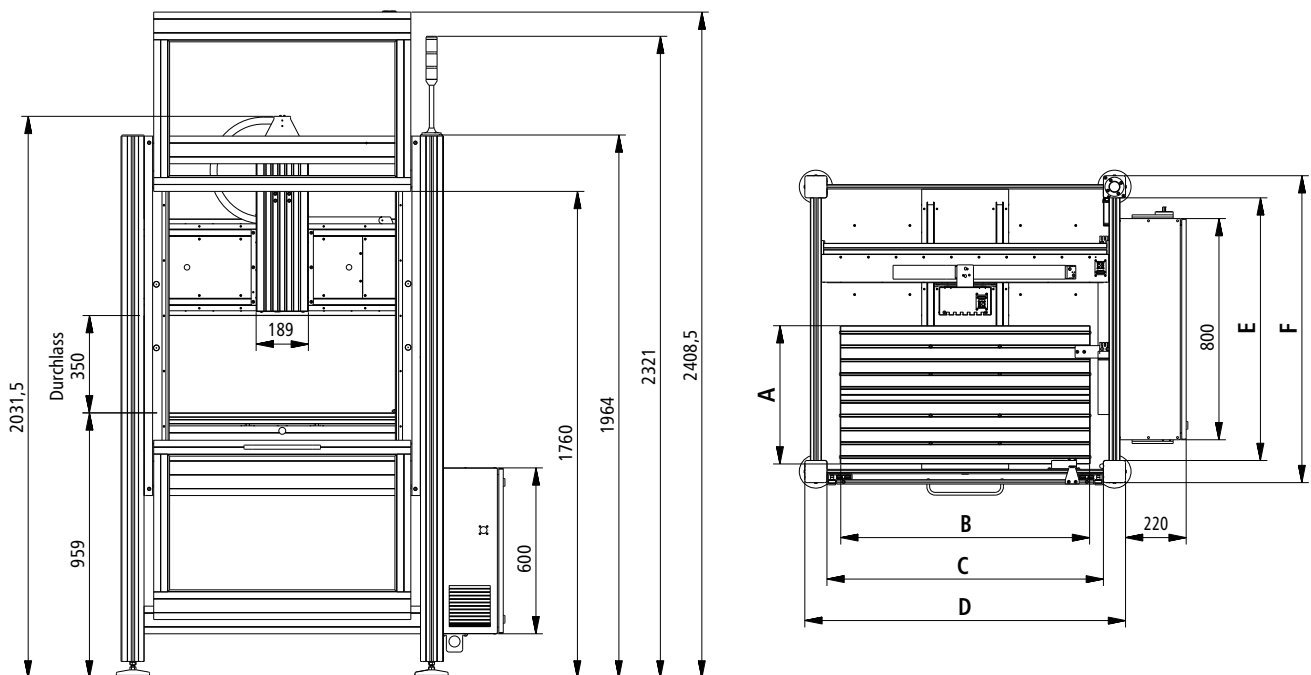

	A	B	C	D	E	F
<b>EuroMod MP30</b>	350	900	1000	1160	640	800
<b>EuroMod MP45</b>	500	900	1000	1160	950	1110
<b>EuroMod MP65</b>	700	1200	1320	1480	1350	1510

Technical specifications subject to change.

# CNC machine with servo motor drive

# ICV4030EC



ICV 4030 EC with machine stand

## Dimensioned drawings

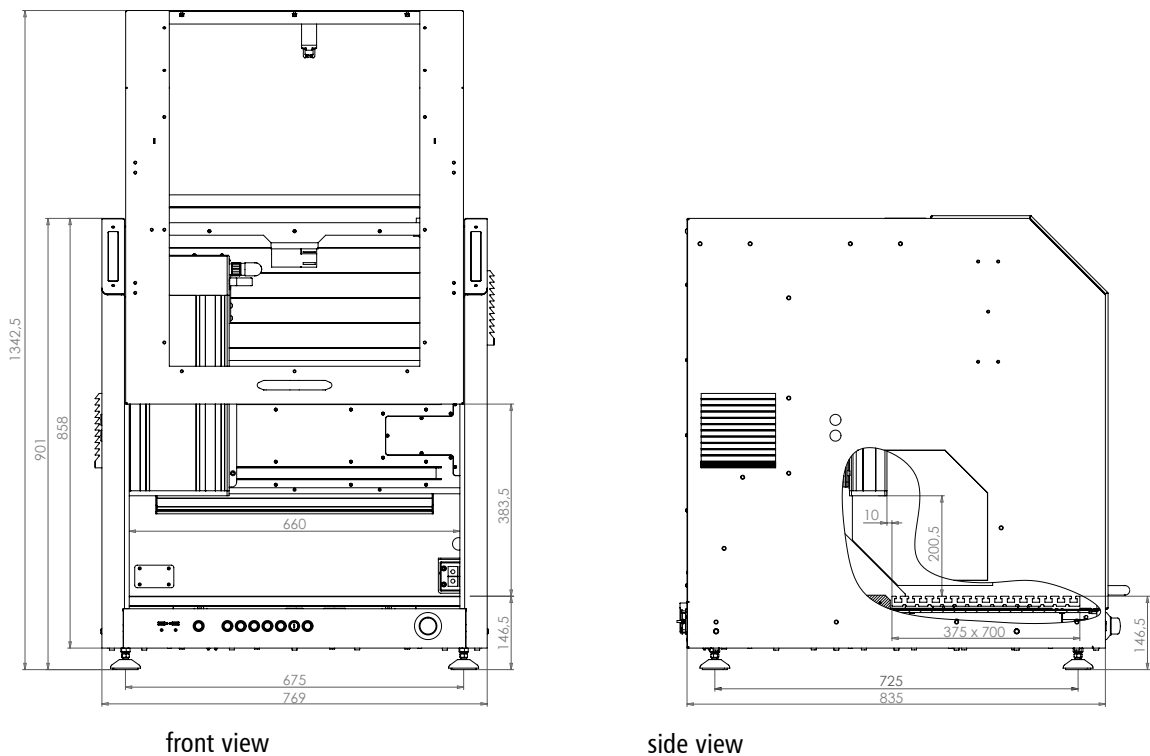

## CNC machine with servo motor drive

# ICV 4030 EC

Our ready-to-use desktop machine ICV 4030 EC has been proven for years in practice and will be presented now in a completely new design. The newly designed machine door with improved hood opening allows a longer travel range in the Z-axis, and therefore a higher passage. Due to the redesigned machine hood and the resulting greater access opening, a 4th axis can now be integrated easily. Maintenance-free EC servo motors are used as drive, the reliable linear unit LES 5 is used in the X-axis. Furthermore, the universal control PC iPC 25 is installed. The central lubrication makes the machine overall more service-friendly. Also additional signal lamps were integrated.

### Technical specifications

	ICV 4030 EC
Processing areas X/Y/Z [mm]	400 x 300 x 140
Bench clamping area WxD [mm]	700 x 375
Gap [mm]	200
Dimensions WxDxH [mm]	769 x 836 x 901
Guides	linear units with precision steel shafts and ball recirculation carriage, adjustable for no play
Processing speed X/Y/Z [mm/s]	max. 200
Repeat accuracy [mm]	± 0.02
Drive motors	servo motors
Drive elements X/Y/Z	Ball screws 16 x 10 / 16 x 10 / 16 x 5 mm adjustable for no play
Controller	CAN-Controller iMC with 3 drive control modules, integrated controll computer, I/O module, safety circuit and standstill monitoring, power supply 48 V / 1,000 Watt
Operation	function keys and emergency stop
Software	WinRemote (optionally: ProNC, CAD/CAM isy 2.8)
Weight (kg)	approx. 150
Item-No.	<b>280260 0001</b>

Overview machine configuration  
see page E-20

### Accessories

680670 9300V02	machine stand, RAL 7016/3003
442107	monitor support - WLB511, VESA 100 x 100, wall mounting / gas spring
442057	23.6" LED-monitor
370321 2003	metal industrial keyboard with touchpad and 105 Keys, USB-interface, IP68
310704 1631	spindle motor iSA 500 with frequency converter
310707 1631	spindle motor iSA 750 with frequency converter
310709 3612	spindle motor iSA 900 with frequency converter
239170 0001	collets ER 11 for iSA 500 and iSA 900, 13-piece, Ø 1-7 mm
239171 0001	collets ER 16 for iSA 750, 10-piece, Ø 1-10 mm
239011 0053	tool changing station 5-fold linear changer, for SK 11 tool holders
239111 0001	tool holder SK 11 for collets ER 11
280120 9010	length measuring sensor
239012 0000	dust extraction for iSA 500 / 750, opened manually
239012 0004	dust extraction for iSA 900, opening pneumatically
429116 1000	cooling spraying system with one nozzle
266000 0200	rotation unit RDH-XS, HD transmission U=1:101, full-wave design, servo drive
269100 0030	tailstock unit RE-XS for rotary unit RDH-XS
269060 4065	three-jaw chucks
216601 0017	vacuum clamping plates VakuFit L, 210 x 150 mm, with hole grid system
290014	clamping elements set, mechanically
Z13-337070	isy-CAM 2.8
Z11-333500	ProNC Software

# CNC machine with step motor drive

# ICP4030

We offer  
**FINANCING!**



- Features**
- tried-and-tested technology
  - for over 20 years
  - over 2,000 systems sold
  - Operation possible without a connection to a PC
  - suitable for school and training



ICP 4030 with hood open



ICP 4030  
with hood closed

## Maßzeichnungen

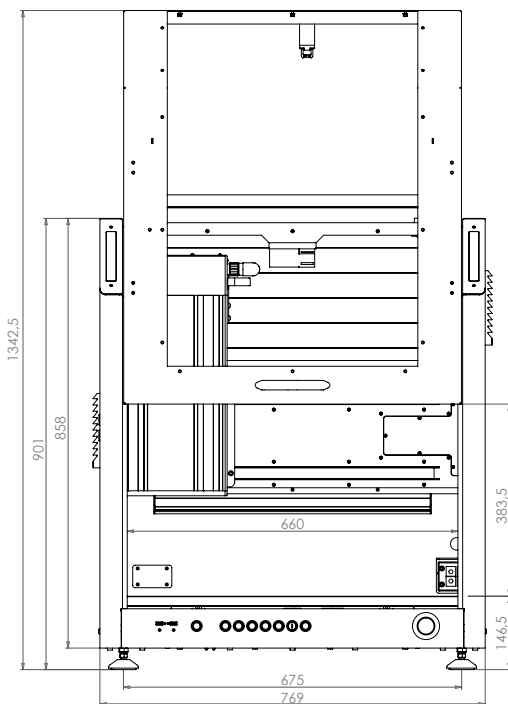

front view

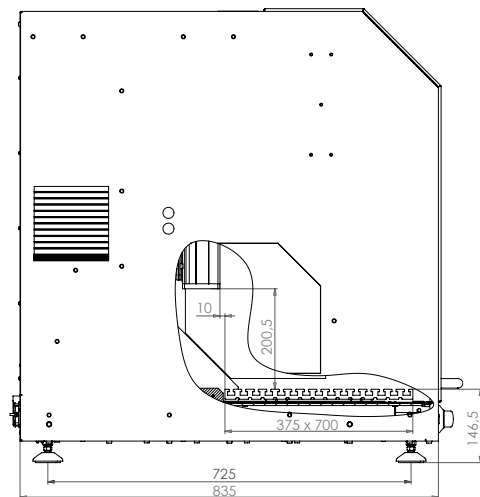

side view

# CNC machine

## with step motor drive

# ICP4030

CNC machines in the ICP series have been developed from the proven CPM series. By introducing a sliding door, the machines can now be operated in a sitting position which, inter alia, leads to shorter cycle times when opening the hood. The chassis is completely bolted instead of being welded like its predecessors. This produces higher precision when building the machine and makes servicing easier. In addition, it was possible to optimise the resonance and vibration behaviour and therefore lower noise build-up has been achieved. The universal control PC iPC 25 is installed.

## Technical specifications

	ICP 4030
Traverse path X/Y/Z [mm]	400 x 300 x 140
Clamping table surface W x D [mm]	700 x 375
Throughput [mm]	200
Dimensions W x D x H [mm]	769 x 836 x 901
Guides	Linear units with precision steel shafts and recirculating ball slots, clearance free adjustable
Process speed X/Y/Z [mm/s]	100 (for Ball screw drives 16x10) 60 (for Ball screw drives 16x4)
Repeatability [mm/s]	± 0.02
Drive motors	Stepper motors
Drive elements X/Y/Z	Ball screw drives 16 x 10 / 16 x 10 / 16 x 4 mm Clearance free adjustable (optional: 16 x 4 mm in X/Y/Z)
Controller	iMC-P step controller with 4 final stages 48V/4.2A, integrated control computer, and 500W power supply unit with processor board
Operation	Function keys and emergency shutdown
Software	WinRemote (optional: ProNC, isy CAM 2.8)
Weight [kg]	appr. 150
Part-no.:	<b>280270 0001*</b>

\* The deliverables include an accompanying pack with mechanical accessories (inter alia Hand lever clamping device, stop rails Triangle wrench, open jaw wrench, hook wrench, Allen key, one 6-socket bench extension, connection lead, power lead)

Overview machine  
configuration  
see page E-20

## Accessories

680670 9300V02	machine stand, RAL 7016/3003
442107	monitor support - WLB511, VESA 100 x 100, wall mounting / gas spring
442057	23.6" LED-monitor
370321 2003	metal industrial keyboard with touchpad and 105 Keys, USB-interface, IP68
280220 9012	Cooling/spray device for ICP 4030
280120 9010	Length measuring button for ICP 4030
280110 9004	Workspace lighting for ICP 4030
420003 0500	Milling motor UFM 500, 500 W, 11,000...25,000 r.p.m.
280110 9001	Suction device for UFM 500
Z13-337070	isy-CAM 2.8
Z11-333500	ProNC software
310704 1611	iSA 500 spindle motor up to 30,000 rpm, 500 W, with frequency converter, ER 11 clamping ring and motor lead
310707 1611	iSA 750 spindle motor up to 24,000 rpm, 750 W, with frequency converter, ER 16 clamping ring and motor lead
280210 9001	Suction device for iSA 500 / 750
280000 0046	Fixing plate for main spindle drive iSA 500 / 750
290055	Vice 1 (W 130 x H 45 x L 152 mm)
290056	Vice 2 (W 180 x H 75 x L 215 mm)

# Flat bed units



Flat bed unit with Z-axis



Flat bed unit with Z-axis and underframe



Flat bed unit with Z-axis, underframe and housing

## General note

Flatbed units as defined in the machine guidelines as incomplete machines according to the modular system with processing paths of 250 to 1250 mm. Step motors (MS200HT), set for no-play, are used as spindle drives. Recirculating ball drives with a repeatability of  $\pm 0.02$  mm (positioning reproducibility) are used. The linear guides used are the isel double track feeds, proven over many years, with no-play pre-stressed linear ball bearings and recirculating ball spindles with a repeatability of  $\pm 0.02$  mm. All units are equipped with two limit switches per spindle. The machining and positioning units are available in a number of versions and are characterised by smooth running and high process speeds. The use of high quality aluminium components with flat-milled surfaces achieves low weight and high accuracy. isel X/Y/Z units are the ideal basis for setting up machines and systems for fitting and assembling, pressing and engraving, drilling and milling, milling and screwing, shaping and modelling, bonding and casting, soldering and welding, measuring and checking, sawing and cutting, etc.

## Ordering information

### X/Y flatbed units FB2

Part no.	Chassis A x B (mm)	Clamping surface X x Y (mm)	process travel X x Y (mm)	Z gap (mm)
246203M	1,210 x 946	750 x 850	530 x 500	190
246203 2040M	1,210 x 1,196	750 x 1,100	530 x 750	
246203 2054M	1,210 x 1,446	750 x 1,350	530 x 1,000	
246203 2067M	1,460 x 1,446	1,000 x 1,350	780 x 850	
246203 2130M	1,710 x 1,846	1,250 x 1,750	1,030 x 1250	

All flatbed units are fitted with **16 x 4 mm recirculating ball** drives as standard. Side protection covers included in smallest version (530 x 500 mm).

### Z-axes for flatbed units

Part no.	Lift (mm)	
230514M	75	with magnet brake 24 V
230514 0400M	160	with magnet brake 24 V

### Underframes

Part no.	suitable for flatbed unit With clamping surface:
248500 0027	750 x 850
248500 0040	750 x 1,100
248500 0054	750 x 1,350
248500 0067	1,000 x 1,350
248500 0130	1,250 x 1,750

### Housings

Part no.	suitable for flatbed units with clamping surface:
248200 0000	750 x 850
248200 2040	750 x 1,100
248200 2054	750 x 1,350
248200 2067	1,000 x 1,350
248200 2130	1,250 x 1,750



# Flat bed units

## Options

- appropriate Controller (e.g.: iMC-S8)
- software modules for operating in CAM, CNC and SPS applications
- underframe
- housing
- spindle motors (see pages E-24 et seq.)
- gap: 300 and 500 mm respectively

## Accessories

Part no.	
<b>219200 0001</b>	Energy guidance chain
<b>645201 0073</b>	Set of side protection covers, L 1050 mm
<b>645201 00731</b>	Set of side protection covers, L 1300 mm
<b>645201 00732</b>	Set of side protection covers, L 1700 mm

## Software

Part-no.	
<b>Z11 - 333 500</b>	ProNC Software
<b>Z13 - 337 070</b>	isy-CAM 2.8

## Dimensioned drawings

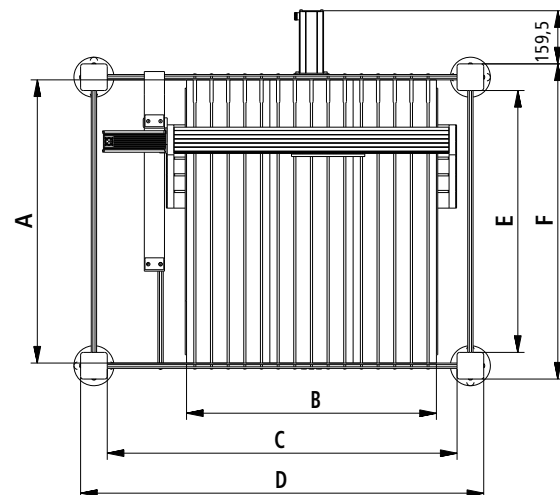
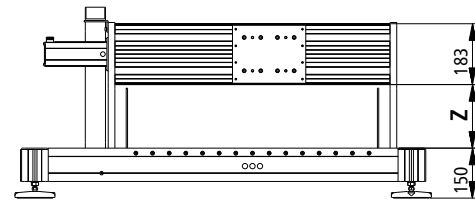
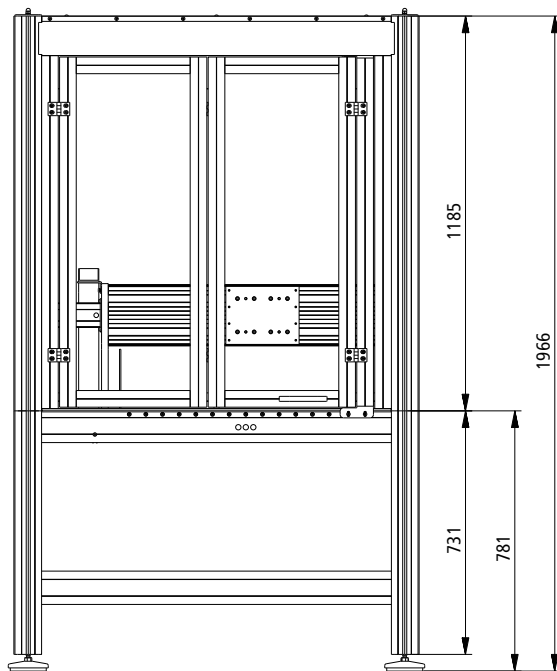

Part-no.	Travel [mm]		Bench clamping area						
	X	Y	A	B	C	D	E	F	Z
<b>246203M</b>	530	500	850	750	1,050	1,210	786	946	190
<b>246203 2040M</b>	530	750	1,100	750	1,050	1,210	1,036	1,196	
<b>246203 2054M</b>	530	1,000	1,350	750	1,050	1,210	1,286	1,446	
<b>246203 2067M</b>	780	850	1,350	1,000	1,300	1,460	1,286	1,446	
<b>246203 2130M</b>	1,030	1,250	1,750	1,250	1,550	1,710	1,686	1,846	

Technical specifications subject to change.

# Machine configuration

	<b>EUROMOD®</b>				
	<b>ICP4030</b>	<b>ICV4030EC</b>	<b>MP30</b>	<b>MP45</b>	<b>MP65</b>
<b>main spindle drive iSA 500</b>	•	•	•	•	•
dust exhaust system ASV 5075	•	•	•	•	•
<b>main spindle drive iSA 500 (CoolMin internal)</b>	•	•	•	•	•
dust exhaust system ASV 5075					
<b>main spindle drive iSA 750</b>	•	•	•	•	•
dust exhaust system ASV 5075	•	•	•	•	•
<b>main spindle drive iSA 750 (CoolMin internal)</b>	•	•	•	•	•
dust exhaust system ASV 5075					
<b>main spindle drive iSA 900</b>		•	•	•	•
dust exhaust system ASV 900		•	•	•	•
linear tool change station SK 11, 5x		•	•	•	•
linear tool change station SK 11, 8x			• <sup>1</sup>	•	•
turned tool change station SK 11, 12x			• <sup>4</sup>	• <sup>4</sup>	• <sup>4</sup>
<b>main spindle drive iSA 1500</b>			•	•	•
dust exhaust system ASV 1500			•	•	•
<b>main spindle drive iSA 1500 (CoolMin internal)</b>			•	•	•
dust exhaust system ASV 1500					
<b>main spindle drive iSA 1500 L</b>			•	•	•
dust exhaust system ASV 1500 L			•	•	•
<b>main spindle drive iSA 1500 WL / iSA 2200</b>			•	•	•
dust exhaust system ASV 2200			•	•	•
linear tool change station SK 20, 4x (Raster 100)				•	•
linear tool change station SK 20, 8x (Raster 100)					• <sup>1</sup>
linear tool change station SK 20, 5x (Raster 170)					
linear tool change station SK 20, 10x (Raster 170)					
turned tool change station SK 20, 14x				• <sup>4</sup>	• <sup>4</sup>
<b>main spindle drive iSA 2200 (CoolMin internal)</b>			•	•	•
dust exhaust system ASV 2200					
<b>main spindle drive iSA 3600</b>			• <sup>3</sup>	• <sup>3</sup>	• <sup>3</sup>
dust exhaust system ASV 3600			•	•	•
linear tool change station SK 30, 4x (Raster 185)					• <sup>1</sup>
linear tool change station SK 30, 5x (Raster 185)					• <sup>1</sup>
linear tool change station SK 30, 8x (Raster 185)					
linear tool change station SK 30, 10x (Raster 185)					

<sup>1</sup> rear mounting only

<sup>2</sup> increased flow only

<sup>3</sup> pitch 2,5 mm in Z-axis only

<sup>4</sup> without the dust exhaust system

# Machine configuration

	<b>OVERHEAD®</b>					<b>FLATCom® XL</b>				
	M20	M30	M40	M50	M60	102/72	102/112	142/112	142/162	142/252
<b>main spindle drive iSA 500</b>	•	•	•	•	•	•	•	•	•	•
dust exhaust system ASV 5075	•	•	•	•	•	•	•	•	•	•
<b>main spindle drive iSA 500 (CoolMin internal)</b>	•	•	•	•	•	•	•	•	•	•
dust exhaust system ASV 5075										
<b>main spindle drive iSA 750</b>	•	•	•	•	•	•	•	•	•	•
dust exhaust system ASV 5075	•	•	•	•	•	•	•	•	•	•
<b>main spindle drive iSA 750 (CoolMin internal)</b>	•	•	•	•	•	•	•	•	•	•
dust exhaust system ASV 5075										
<b>main spindle drive iSA 900</b>	•	•	•	•	•	•	•	•	•	•
dust exhaust system ASV 900	•	•	•	•	•	•	•	•	•	•
linear tool change station SK 11, 5x	•	•	•	•	•	•	•	•	•	•
linear tool change station SK 11, 8x	•	•	•	•	•	•	•	•	•	•
turned tool change station SK 11, 12x	●4	●4	●4	●4	●4	●2,4	●2,4	●2,4	●2,4	●2,4
<b>main spindle drive iSA 1500</b>	•	•	•	•	•	•	•	•	•	•
dust exhaust system ASV 1500	•	•	•	•	•	•	•	•	•	•
<b>main spindle drive iSA 1500 (CoolMin internal)</b>	•	•	•	•	•	•	•	•	•	•
dust exhaust system ASV 1500										
<b>main spindle drive iSA 1500 L</b>	•	•	•	•	•	•	•	•	•	•
dust exhaust system ASV 1500 L	•	•	•	•	•	•	•	•	•	•
<b>main spindle drive iSA 1500 WL / iSA 2200</b>	•	•	•	•	•	•	•	•	•	•
dust exhaust system ASV 2200	•	•	•	•	•	•	•	•	•	•
linear tool change station SK 20, 4x (Raster 100)										
linear tool change station SK 20, 8x (Raster 100)										
linear tool change station SK 20, 5x (Raster 170)	●1	•	•	•	•		•	•	•	•
linear tool change station SK 20, 10x (Raster 170)					●4				●4	•
turned tool change station SK 20, 14x	●4	●4	●4	●4	●4	●2,4	●2,4	●2,4	●2,4	●2,4
<b>main spindle drive iSA 2200 (CoolMin internal)</b>	•	•	•	•	•	•	•	•	•	•
dust exhaust system ASV 2200										
<b>main spindle drive iSA 3600</b>	●3	●3	●3	●3	●3	●3	●3	●3	●3	●3
dust exhaust system ASV 3600	•	•	•	•	•	•	•	•	•	•
linear tool change station SK 30, 4x (Raster 185)	●1	•	•	•	•		●2	●2	●2	●2
linear tool change station SK 30, 5x (Raster 185)		●4	●4	•	•		●2	●2	●2	●2
linear tool change station SK 30, 8x (Raster 185)				●4	●4				●2	●2
linear tool change station SK 30, 10x (Raster 185)										●2

1 rear mounting only

2 increased flow only

3 pitch 2,5 mm in Z-axis only

4 without the dust exhaust system

# Accessories

# spindle motors and more



When developing our spindle motors, our main emphasis was on functionality, quality, and the optimum price structure. Our spindle motors are also particularly easy to maintain. The particularly slim lines and square housing cross-section allow installation in rows with minimum separation. Our approach to electrical construction is to use an AC short circuit rotor with 2-pole windings in our motors, designed to DIN EN 60034.

The insulation of the windings is produced according to heat class F. The motors are dynamically balanced to very fine tolerances, so that good running properties are achieved even at high speeds. In all, they cover a range of speeds from 3,000 to 30,000 rpm. All spindle motors are produced entirely in Germany, meet at least the criteria for IP54 protection class and are therefore approved even for areas where wood dust is present. In our product portfolio, in addition to spindle motors, you'll find all the leads you will need in various lengths and preset, reliable frequency converters for connecting to the controller. By integrating development, production, sales and service under one roof, we have very short procedures and have our own repair service which operates year-round, unlike many of our competitors.

An extensive range of accessories, such as vacuum cleaning systems, minimum amount greasing systems, collets, SK housings, tool changers and our unique, patented Coolmin system for optimum and economical tool cooling, without residues, round off our product portfolio.

# Accessories

## Overview

### Spindle motors iSA-series

<b>iSA 500</b> with manual tool changer	E-24
<b>iSA 750</b> with manual tool changer	E-25
<b>iSA 900</b> mit automatischem Werkzeugwechsler	E-26
<b>iSA 1500</b> with manual tool changer	E-27
<b>iSA 1500 L</b> with manual tool changer	E-28
<b>iSA 1500 WL</b> with automatic tool changer	E-29
<b>iSA 2200</b> with automatic tool changer	E-30
<b>iSA 3600</b> with automatic tool changer	E-31

### Spindle motors HSD-series

<b>Milling spindle ES 325 HSK 25</b> and suitable collets	E-32
---	------

### High frequency spindles HFS-series

<b>HFS 800</b> for manual tool changing	E-33
<b>HFS 1500</b> for manual tool changing	E-34
<b>HFS 2200</b> for manual tool changing	E-35

### Additional accessories

Dust extraction systems	E-36
CoolMin tool cooling system	E-38
Linear tool change stations SK 11 / 20 / 30 tool holders and length measuring sensor	E-40
Turned tool change stations SK 11 / 20	E-42
Motor leads and dust extraction devices	E-43
Collets	E-44
Vacuum clamping plates	E-45

# Spindle motor with manual tool changer

## iSA 500



iSA 500 with manual tool change

iSA 500 with manual tool change  
and **CoolMin**® tool cooling system

### Features

- robust 2-pole AC motor (asynchronous motor)
- square shape, protection class IP54, isolation class F
- cast bearing apron A-side, aluminium extrusion B-side
- motor shaft to take ER 11 collets
- rated output 0.5 kW (S6-40% operation)
- speed range 5,000 rpm. - 30,000 rpm.
- manual tool change
- M23 plug connection
- incl. ER 11 collet, Ø 6 mm
- clamping range Ø 1 mm – Ø 7 mm
- intrinsic ventilation B-side
- controlled by frequency converter
- spindle bearing: 2 bearings A-side  
1 bearing B-side
- optional:
  - CoolMin® (internal and external)
  - frequency converter
  - various collets, mounting plates, lead lengths
  - suction device

### Technical specification

Description		iSA 500
Torque at rated speed 18,000 rpm	[Nm]	0.28
Speed	[rpm]	5,000 to 30,000
Cut-off frequency	[Hz]	300
Number of poles		2
Rated voltage	[V]	230
Rated current	[A]	2.6
cos φ		0.75
S 6 = 40% rated output	[kW]	0.5
Concentricity	[mm]	0.01
Weight	[kg]	2.8

### Dimensioned drawings

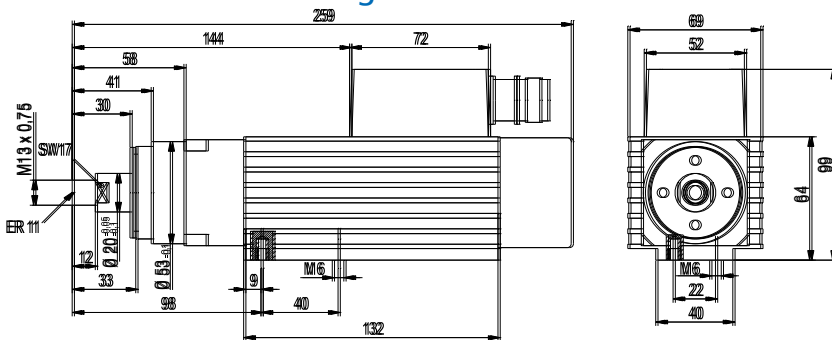

### Torque curves

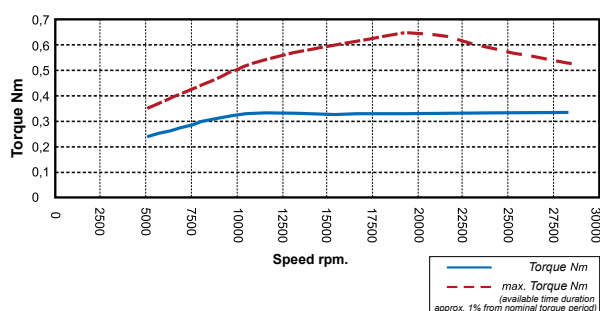

Technical specifications subject to change.

### Ordering information

iSA 500 spindle motor  
Part no.: **477004 3130**

iSA 500 spindle motor  
with converter\* and lead (8m)  
Part no.: **310704 1611**

iSA 500 spindle motor with CoolMin®  
Part no.: **477004 5130**

iSA 500 spindle motor with converter\*,  
lead (8 m) and CoolMin®  
Part no.: **310704 1631**

LES 5 / ICV mounting plate  
Part no.: **277014**

LES 6 / FB 2 mounting plate  
Part no.: **277028 0008 / 277013**

ICP/ICV mounting plate  
Part no.: **280000 0046**

EuroMod/FlatCom mounting plate  
Part no.: **277028**

- M23 motor side leads see page **E-43**
- suction device for 38 mm hose see page **E-43**
- collet set, ER11 type see page **E-44**

\*converter pre-set for spindle

# Spindle motor

## with manual tool changer

# iSA 750



iSA 750 with manual tool change

iSA 750 with manual tool change and CoolMin® tool cooling system

## Technical specification

Description		iSA 750
Torque at rated speed 22,000 rpm	[Nm]	0.34
Speed	[rpm]	3,000 to 24,000
Cut-off frequency	[Hz]	300
Number of poles		2
Rated voltage	[V]	230
Rated current	[A]	3.4
cos $\phi$		0.79
S 6 = 40% rated output	[kW]	0.75
Concentricity	[mm]	0.01
Weight	[kg]	2.6

## Dimensioned drawings

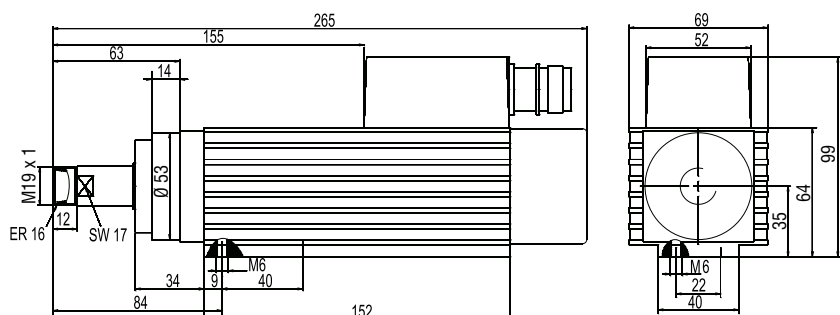

## Torque curves

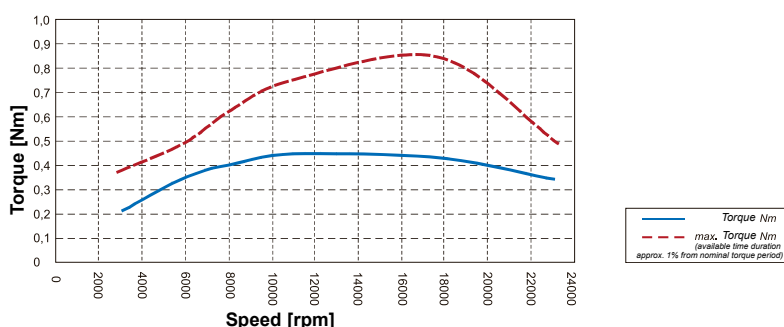

## Features

- robust 2-pole AC motor (asynchronous motor)
- square shape, Protection class IP54, insulation class F
- aluminium extrusion A and B sides
- motor shaft to take ER 16 collets
- rated output 0.75 kW (S6-40% operation)
- speed range 3,000 rpm. - 24,000 rpm.
- manual tool change
- M23 plug connection
- incl. ER16 collet,  $\varnothing$  6 mm
- clamping range  $\varnothing$  1 mm –  $\varnothing$  10 mm
- intrinsic ventilation B-side
- two precision bearings
- controlled by frequency converter
- optional:
  - CoolMin® (internal and external)
  - frequency converter
  - various collets, mounting plates, lead lengths
  - suction device

## Ordering information

iSA 750 spindle motor  
Part no.: **477008 3124**

iSA 750 spindle motor with converter\* and lead (8 m)  
Part no.: **310708 1611**

iSA 750 spindle motor with CoolMin®  
Part no.: **477008 5124**

iSA 750 spindle motor with converter\*, lead (8 m) and CoolMin®  
Part no.: **310707 1631**

LES 5 / FB 2 mounting plate  
Part no.: **277014 / 277013**

LES 6 mounting plate  
Part no.: **277028 0008**

ICP/ICV mounting plate  
Part no.: **280000 0046**

EuroMod/FlatCom mounting plate  
Part no.: **277028**

- M23 motor side leads see page **E-43**
- suction device for 38 mm hose see page **E-43**
- collet set, ER16 type see page **E-44**

\*converter pre-set for spindle

Technical specifications subject to change.

# Spindle motor

with **automatic tool changer**

## iSA 900



iSA 900 with automatic tool change

The spindle motor iSA 900 is suitable for machining light aluminum, wood and plastic.

### Technical specification

Description		iSA 900
Torque at rated speed 18,000 rpm	[Nm]	0.37
Speed	[rpm]	6,000 to 24,000
Cut-off frequency	[Hz]	400
Number of poles		2
Rated voltage	[V]	230
Rated current	[A]	3.25
cos $\phi$		0.84
S 6 = 40% rated output	[kW]	0.9
Concentricity	[mm]	0.01
Weight	[kg]	5.8

### Dimensioned drawings

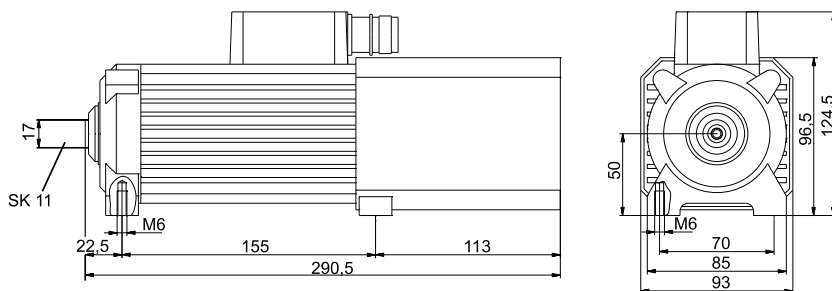

### Torque curves

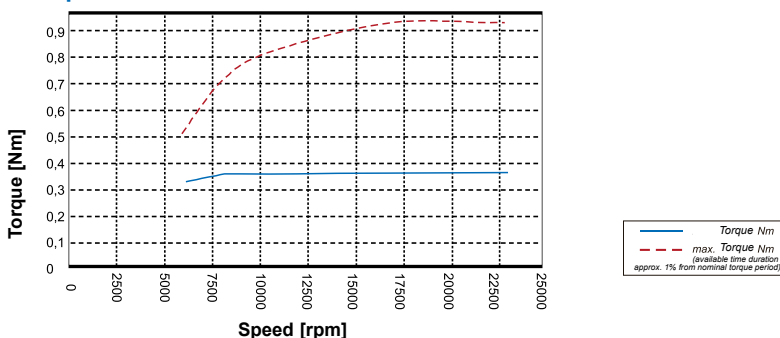

Technical specifications subject to change.

### Features

- robust 2-pole AC motor (asynchronous motor)
  - square shape, Protection class IP55, insulation class F
  - cast bearing apron A and B sides
  - rated output 0.9 kW (S6-40% operation)
  - speed range 6,000 rpm. - 24,000 rpm.
  - automatic tool change with SK 11 tool holder and ER 11 collet,  $\varnothing$  6 mm
  - M23 plug connection
  - clamping range  $\varnothing$  1 mm –  $\varnothing$  7 mm
  - separately driven fan B-side
  - controlled by frequency converter
  - two precision bearings
  - SK 11 tool changer, pneumatic (7.5 bars)
  - max. Tool diameter: 3 mm
  - max. Tool length :  $\varnothing$  x 3
  - recommended tool: 2-cutter
- optional:
- CoolMin® (external)
  - frequency converter
  - tool changing station
  - various collets, mounting plates, lead lengths

### Ordering information

iSA 900 spindle motor  
Part no.: **477009 3324**

iSA 900 spindle motor with converter\* and lead (8m)  
Part no.: **310709 3612**

LES 5 / EuroMod / FlatCom / ICV 4030 mounting plate  
Part no.: **277028 0003**

ICP mounting plate  
Part no.: **277028 0010**

- Cooling system® external with hose see pages **E-38**
- 5× SK 11 tool change stations see pages **E-40**
- 8× SK 11 tool change stations see pages **E-40**
- SK 11 tool holder see pages **E-40**
- M23 motor side connecting leads see pages **E-43**
- collet set, ER11 type see pages **E-44**

\*converter pre-set for spindle



# Spindle motor

## with manual tool changer

# iSA 1500

## Features

- robust 2-pole AC motor (asynchronous motor)
- square shape, protection class IP54, insulation class F
- cast bearing apron A and B sides
- motor shaft to take ER 20 collets
- rated output 1.5 kW (S1-100% operation)
- speed range  
5,000 rpm. - 20,000 rpm.
- manual tool change
- M23 plug connection
- incl. ER20 collet, Ø 6 mm
- clamping range  
Ø 2 mm – Ø 13 mm
- intrinsic ventilation B-side
- controlled by frequency converter
- spindle bearing: 2 bearings A-side  
1 bearing B-side
- optional:
  - CoolMin® (internal and external)
  - frequency converter
  - various collets, mounting plates, lead lengths
  - suction device
  - 4-pole motor version to order

## Ordering information

iSA 1500 spindle motor  
Part no.: **477510 3120**

iSA 1500 spindle motor with converter\*  
and connecting lead (8 m)  
Part no.: **310610 3614**

iSA 1500 spindle motor with CoolMin®  
Part no.: **477510 5120**

iSA 1500 spindle motor with converter\*  
and CoolMin®  
Part no.: **310610 3634**

LES 5 mounting plate  
Part no.: **277028 0003**

EuroMod/FlatCom mounting plate  
Part no.: **277028 0002**

- CoolMin® external with hose  
see page **E-38**
- M23 motor side connecting leads  
see page **E-43**
- suction device for 80 mm hose  
see page **E-43**
- collet set, ER20 type  
see page **E-44**

\*converter pre-set for spindle

iSA 1500 with manual tool change



iSA 1500 with manual tool change  
and CoolMin® tool cooling system

## Technical specification

Description		iSA 1500
Torque at rated speed 20,000 rpm	[Nm]	0.72
Speed	[rpm]	5,000 to 20,000
Cut-off frequency	[Hz]	300
Number of poles		2
Rated voltage	[V]	230
Rated current	[A]	7
cos φ		0.85
S 1 = 100% rated output	[kW]	1.5
Concentricity	[mm]	0.01
Weight	[kg]	6.4

## Dimensioned drawings

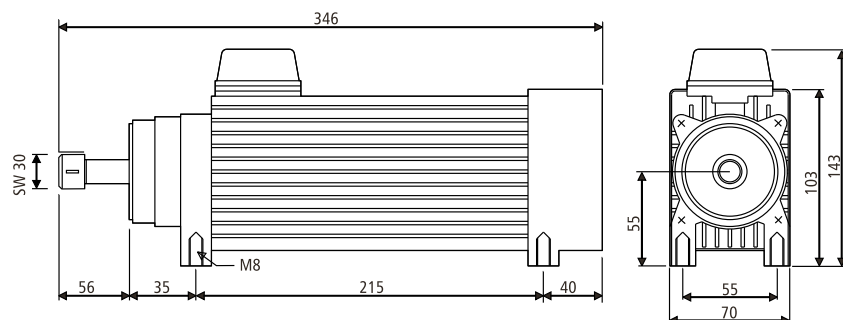

## Torque curves

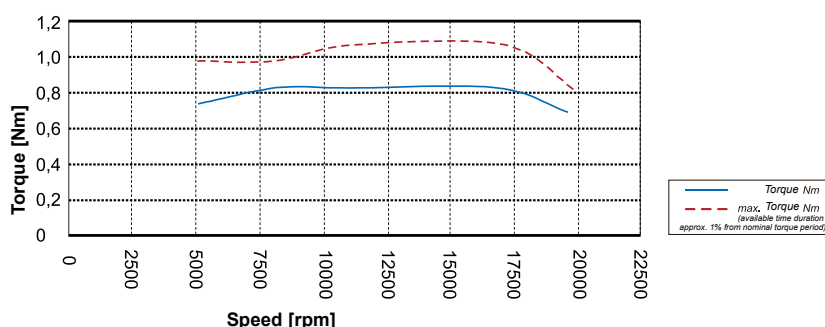

Technical specifications subject to change.

# Spindle motor

## with manual tool changer

# iSA 1500 L



iSA 1500 L with manual tool change

## Technical specification

Description		iSA 1500 L
Torque at rated speed 6,000 rpm	[Nm]	2.37
Speed range	[rpm]	2,500 to 6,000
Cut-off frequency	[Hz]	107
Number of poles		2
Rated voltage	[V]	200
Rated current	[A]	6.5
cos $\phi$		0.84
Rated power (S 6 = 40% operation)	[W]	1500
Concentricity	[mm]	0.01
Weight	[kg]	10.5

## Dimensioned drawings

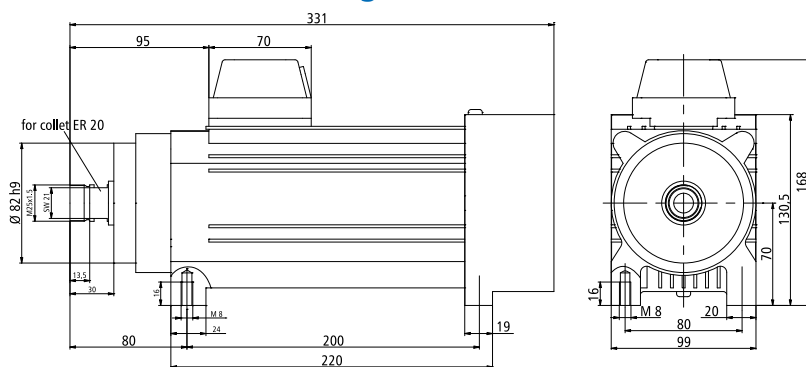

## Torque curves

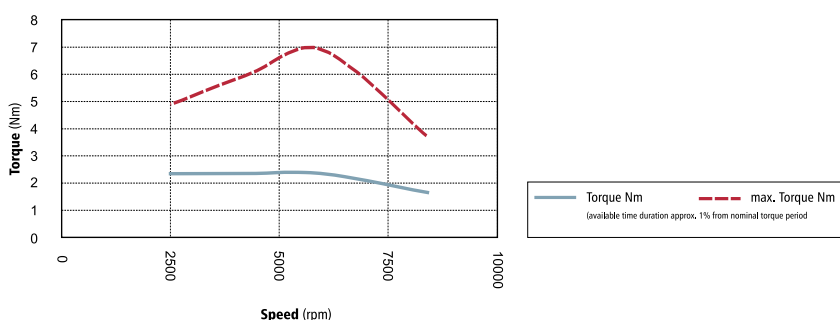

## Features

- robust 2-pole AC motor
- protection class IP54, insulation class F
- motor shaft to take ER 20 collets
- cast bearing apron A and B sides
- rated output 1.5 kW (S6-40% operation)
- rotational speed range 2,500 rpm – 6,000 rpm
- torque 2.37 Nm (at 6,000 rpm)
- rated voltage 200 V
- manual tool change
- clamping range  $\varnothing$  2 mm –  $\varnothing$  13 mm
- intrinsic ventilation B-side
- controlled by frequency converter
- spindle bearing:
  - A-side (milling side) double,
  - B-side (ventilation side) single
- concentricity: 0.01 mm
- weight: 10.5 kg
- optional:
  - CoolMin® Tool and material cooling, external
  - frequency converter
  - collets

## Ordering information

iSA 1500 L spindle motor with collet ER 20 (6 mm), clamping key ER 20, jaw key SW 22, Interconnectron connection

Part no.: **477510 3106**

iSA 1500 L spindle motor with converter\* with collet ER 20 (6 mm), clamping key ER 20, jaw key SW 22, Interconnectron connection

Connecting leads 8 m  
Part no.: **310610 3615**

CoolMin® external  
Part no.: **239011 0119**

Suction device for EuroMod / FlatCom prepared for 38 mm diameter hose  
Part no.: **239012 0001**

Clamping set ER 20  
2.0 / 3.0 / 4.0 / 5.0 / 6.0 / 7.0 / 8.0 / 9.0 / 10.0 / 11.0 / 12.0 / 13.0 mm  
Part no.: **239172 0001**

Mounting plate isel System (Z axis)  
EuroMod / FlatCom (LES 21)  
Part no.: **277028 0011**

Mounting plate isel System (Z axis)  
Linear unit LES 5  
Part no.: **277028 0005**

\*converter pre-set for spindle

Technical specifications subject to change.

# Spindle motor

with automatic tool changer

## iSA 1500WL



iSA 1500WL

iSA 1500WL with **CoolMin®**  
tool cooling system

### Technical Data

Description		iSA 1500WL
Torque at nominal speed 6,000 rpm	[Nm]	2,5
Max. Speed	[rpm]	1,000 - 20,000
Cut-off frequency	[Hz]	100
Number of poles		2
Rated voltage	[V]	3 x 230 /star connection
Rated current	[A]	6
cos $\phi$		0.35
Rated power (S6 = 40% operation)	[W]	1,500
Concentricity	[mm]	0.01
Weight	[kg]	14.0

### Features

- robust 2-pole AC motor (hardened motor shaft)
- protection class IP55, Isulation class F
- cast bearing apron A and B sides
- rated output 1.5 kW (S6-40% operation)
- rotational speed range 6,000 rpm / 100 Hz
- rated torque 2.5 Nm (at 6,000 rpm)
- specific torque rating for drilling and lowering in the speed range 1,000-20,000 rev / min
- rated voltage 3 x 230 V
- automatic tool change
- clamping range  $\varnothing$  2 mm –  $\varnothing$  13 mm
- separately driven fan B-side
- controlled by frequency converter
- double precision bearings
- SK 20 tool changer pneumatic (7,5 bar)
- concentricity: 0.01 mm
- weight: 14.0 kg

- optional:
  - CoolMin® Tool and material cooling (external and internal)
  - frequency converter
  - tool changer
  - collets

### Ordering information

Spindle motor iSA 1500WL  
with collets ER 20 (6 mm), nut ERM 20, clamping key ER 20 M,  
jaw key SW 22, Interconnection connection

Part no.: **477015 3320**

Spindle motor iSA 1500WL as above, plus  
frequency converter\* SKC 1500, motor connecting cable 8 m

Part no.: **310715 3621**

SK 20 tool change station 4-fold with hood

Part no.: **239011 0041**

SK 20 tool holder

Part no.: **239172 0020**

CoolMin® (external)

Part no.: **239011 0119**

Clamping set ER 20

2 / 3 / 4 / 5 / 6 / 7 / 8 / 9 / 10 / 11 / 12 / 13.0 mm

Part no.: **239172 0001**

Mounting plate isel systems (Z-axis) LES 5

Part no.: **277028 0019**

\*converter pre-set for spindle

### Dimensioned drawings

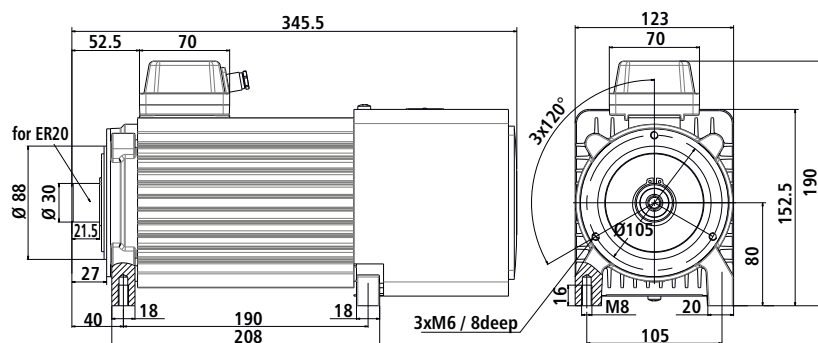

### Torque curves

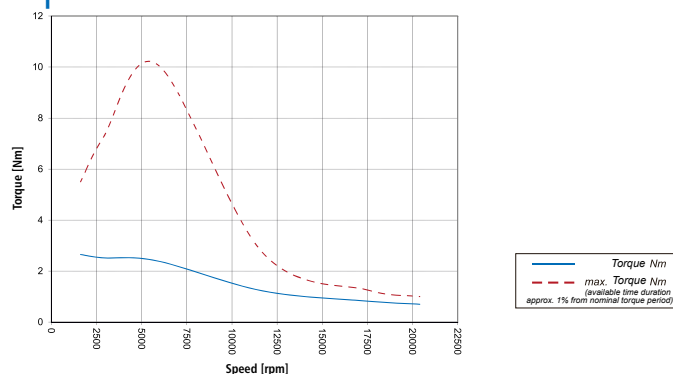

Technical specifications subject to change.

# Spindle motor

with automatic tool changer

## ISA 2200



### Technical specification

Description		ISA 2200
Torque at rated speed 18,000 rpm.	[Nm]	1.26
Speed range	[rpm]	5,000 to 20,000
Cut-off frequency	[Hz]	300
Number of poles		2
Rated voltage	[V]	3 x 230
Rated current	[A]	7.6
cos φ		0.84
Rated power (S 6 = 40% operation)	[W]	2.2
Concentricity	[mm]	0.01
Weight	[kg]	14.6

### Dimensioned drawings

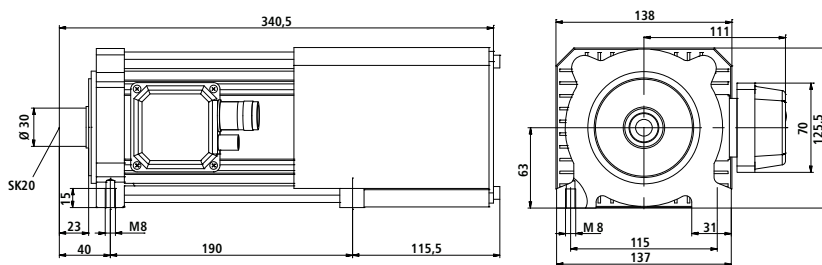

### Torque curves

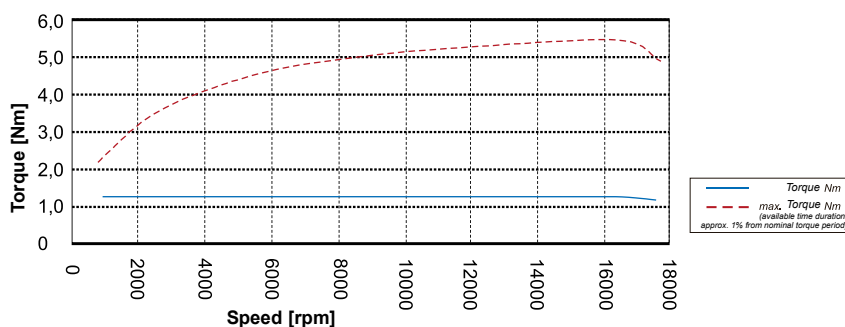

### Features

- robust 2-pole AC motor
- protection class IP55, insulation class F
- cast bearing apron A and B sides
- rated output 2.2 kW (S6-40% operation)
- rotational speed range 5,000 rpm – 20,000 rpm
- torque 1.26 Nm (at 18,000 rpm)
- rated voltage 3 x 230 V
- automatic tool change
- clamping range  $\varnothing 2 - \varnothing 13$  mm
- separately driven fan B-side
- controlled by frequency converter
- two precision bearings
- SK 20 tool changer, pneumatic (7.5 bars)
- concentricity: 0.01 mm
- weight: 14.6 kg
- optional:
  - CoolMin® Tool and material cooling, external
  - CoolMin® internal with **internal tool cooling**
  - frequency converter
  - tool changer, collets

### Ordering information

ISA 2200 spindle motor  
with collets ER 20 (6 mm), nut ERM 20, clamping key ER 20 M, jaw key SW 22, Interconnection connection  
Part no.: **477022 3320**

ISA 2200 spindle motor as above, plus frequency converter\* SKC 1500, motor connecting cable 8 m  
Part no.: **310722 3621**

ISA 2200 spindle motor + CoolMin® (internal)  
with collets ER 20 (6 mm), nut ERM 20, clamping key ER 20 M, jaw key SW 22, Interconnection connection  
Part no.: **477022 5320**

ISA 2200 with converter\* + CoolMin® (internal)  
as above, plus frequency converter SKC 1500, motor connecting cable 8 m Part no.: **310722 3631**

SK 20 tool change station 4-fold with hood  
Part no.: **239011 0041**

SK 20 tool holder  
Part no.: **239172 0020**

Suction device for EuroMod/FlatCom, prepared for hose  $\varnothing 80$  mm, pneumatic opening  
Part no.: **239012 0002**

Suction device with CoolMin® (external)  
for EuroMod/FlatCom, prepared for hose  $\varnothing 80$  mm, pneumatic opening  
Part no.: **239012 0003**

CoolMin® (external)  
Part no.: **239011 0119**

Clamping set ER 20 2.0/3.0/4.0/5.0/6.0/7.0/8.0/9.0/10.0/11.0/12.0/13.0 mm Part no.: **239172 0001**

Mounting plate isel System (Z axis)  
FlatCom / EuroMod Part no.: **277028 0004**  
LES 5 Part no.: **277028 0005**

Technical specifications subject to change.

# Spindle motor

with **automatic tool changer**

## iSA 3600



iSA 3600 with automatic tool change

### Features

- robust 2-pole AC motor
- square shape, protection class IP54, insulation class F
- cast bearing apron A-side, aluminium extrusion B-side
- motor shaft to take ER 32 collets
- rated output 3.6 kW (S6-40% operation)
- speed range 6,000 rpm. - 18,000 rpm.
- automatic tool changer with SK 30 tool holder and ER 32 collet, Ø 6 mm
- damping range Ø 3 mm – Ø 20 mm
- intrinsic ventilation B-side
- two precision bearings
- controlled by frequency converter
- optional:
  - CoolMin® (external)
  - frequency converter
  - tool changing station
  - various collets, mounting plates and lead lengths

### Technical specification

Description		iSA 3600
Torque at rated speed 18,000 rpm	[Nm]	4.5
Speed	[rpm]	6,000 to 18,000
Cut-off frequency	[Hz]	300
Number of poles		2
Rated voltage	[V]	3 x 400
Rated current	[A]	5.4
cos φ		0.87
S6 = 40% rated output	[kW]	3.6
Concentricity	[mm]	0.01
Weight	[kg]	23.0

### Ordering information

iSA 3600 spindle motor  
Part no.: **477822 3600**

iSA 3600 spindle motor with converter\*  
and connecting lead (8 m)  
Part no.: **310736 3615**

mounting plates LES 5 / FlatCom XL  
Part no.: **277028 0009**

- CoolMin® external with hose see page **E-38**
- 4× SK 30 tool change stations see page **E-40**
- 5× SK 30 tool change stations see page **E-40**
- SK 30 tool holder see page **E-40**
- M23 motor side leads see page **E-43**
- collet set, type ER 32 see page **E-44**

### Dimensioned drawings

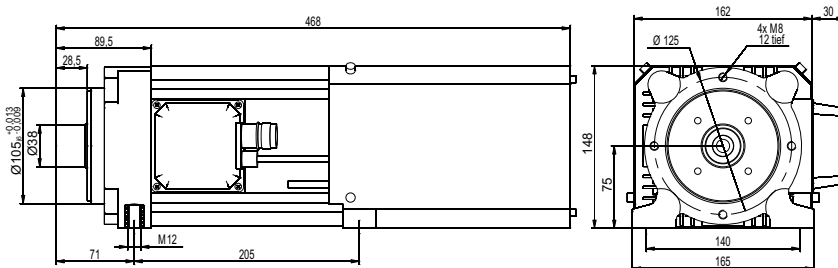

### Torque curves

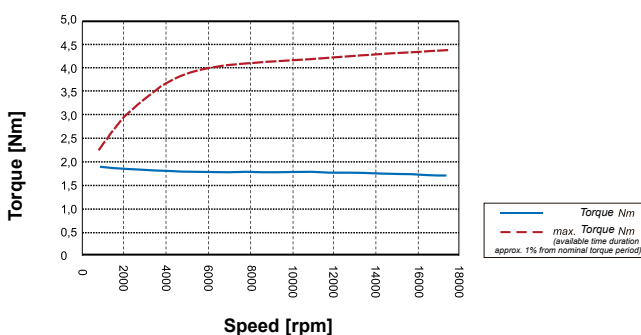

\*converter pre-set for spindle

Technical specifications subject to change.

# Milling spindle

## HSD-series

# ES 325 HSK 25



## Features

- automatic tool locking with pneumatic piston
- front ceramic bearing
- rear ceramic bearing
- lifetime lubrication
- max. speed: 40.000 rpm
- spindle housing aluminium alloyed
- cooling = air cooled up to 40.000 rpm or water cooled up to 50.000 rpm
- weight: 7 kg
- optional
  - linear tool changer HSK 25
  - clamp for HSK 25 and HSK 32
  - tool holders
  - CoolMin external

## Ordering information

Milling spindle ES 325 HSK 25  
Part no.: **478015 1340**

Milling spindle ES 325 HSK 25  
with converter\* Maintenance unit and connection  
line 8 m, Collet EX 16, 6 mm, air or water cooled  
Part no.: **310815 3511**

Frequency converter SKC 4000  
Part no.: **311740 6500**

CoolMin® (extern)  
Part no.: **239011 0119**

Tool holders HSK 25  
Part no.: **477125**

Collets  $\varnothing$  1,0 / 1,5 / 2,0 / 2,5 / 3,0 / 4,0 / 5,0 / 6,0 / 7,0 /  
8,0 / 9,0 / 10,0  
Part no.: **477125 80XX**

Clamps  
for holding HSK 25 Part no.: **639100 0043**  
for holding HSK 32 Part no.: **639100 0044**

Linear tool change station HSK 25  
5x Part no.: **239011 0051**  
10x Part no.: **239011 0101**

Mounting plate LES 5 and LES 21  
Art.-Nr.: **277028 0001**

Cooling unit 16 S for milling spindle ES 325  
Art.-Nr.: **492015 2001**

Storage rack for cooling unit 16 S  
Art.-Nr.: **274507 6300**

Compressed air with a purity according to  
ISO 8573-1, of classes 2 4 3

## Technical specification

Description		ES 325 HSK 25
Rated speed	[min <sup>-1</sup> ]	40.000
Rated voltage	[V]	380
Rated current	[A]	4,0
max. rated output	[kW]	2,0
Weight	[kg]	7,0

## Dimensioned drawings

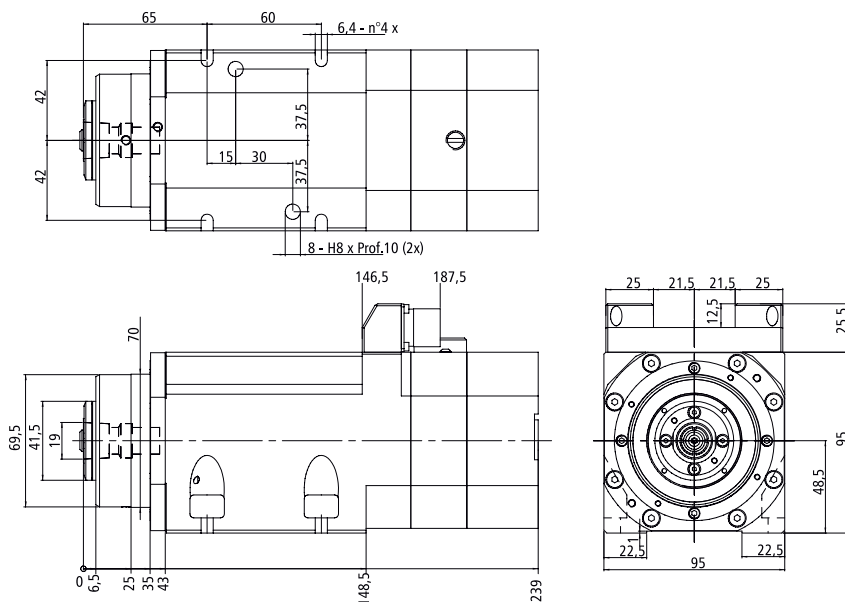

# High frequency spindle

for manual tool changing

## HFS 800



### Features

- solid 2-pole three-phase motor
- round design
- protection class IP 54, insulation class F, CE
- motor shaft for holding ER 11 clamping jaws
- rated power 0,8 kW
- speed range 5.000 - 24.000 rpm
- torque 0,32 Nm (at 24.000 rpm)
- rated voltage 220 V
- manual tool changer
- clamping range  $\varnothing$  0,5 - 7,0 mm
- self ventilated at B side
- connection M23
- speed control by frequency converter
- concentricity: 0,01 mm
- weight: 2,9 kg

- optional
  - clamping block
  - frequency converter
  - brake resistor
  - exhaust system
  - range of different collets ER 11
  - various lengths of connection leads

### Technical specification

Description		HFS 800
Torque at rated speed 24.000 U/min.	[Nm]	0,32
Speed	[rpm.]	5.000 ... 24.000
cut-off frequency	[Hz]	400
Number of poles		2
Rated voltage	[V]	220
Rated current	[A]	2,5
cos $\phi$		0,9
Rated power	[kW]	0,8
Concentricity	[mm]	0,01
Weight	[kg]	2,9

### Dimensioned drawings

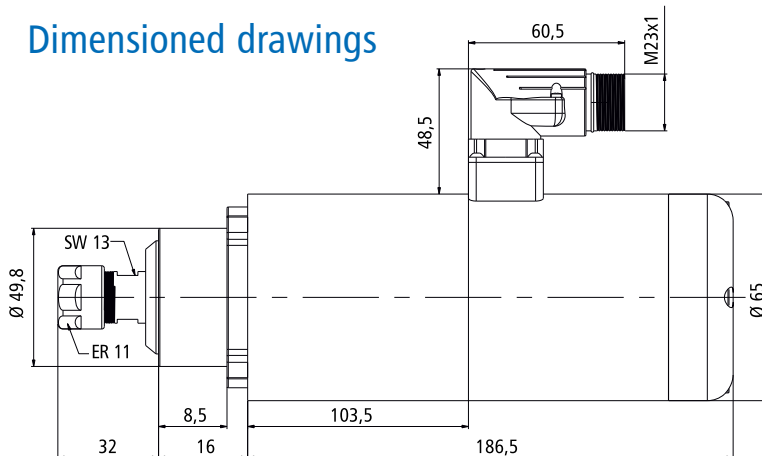

### Ordering information

#### HFS 800

Asynchronous spindle 0,8 kW  
with collet ER 11 (3 mm and 6 mm)  
Part no.: **477008 30240**

#### HFS 800 with converter\*

with collet ER 11 (6 mm), connection lead 8 m  
Part no.: **310802 2014**

#### Hedy frequency converter

vector controlled, 750 VA (1-phase)  
Part no.: **311802 1000**

#### Clamping set ER 11

1,0 / 1,5 / 2,0 / 2,5 / 3,0 / 3,5 / 4,0 / 4,5 / 5,0 / 5,5 / 6,0 /  
6,5 / 7,0 mm  
Part no.: **239170 0001**

#### Clamping block SB 65

with slide nuts and screws  
Part no.: **290904 0065**

\*converter pre-set for spindle

### Torque curves

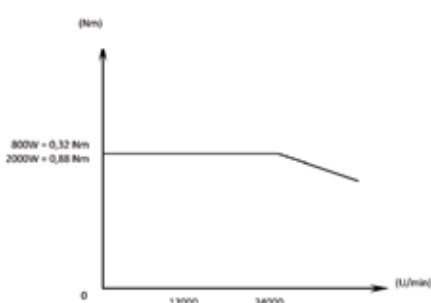

Technical specifications subject to change.

# High frequency spindle

## for manual tool changing

# HFS 1500



## Features

- solid 2-pole three-phase motor
  - round design
  - protection class IP 54, insulation class F, CE
  - motor shaft for holding ER 16 clamping jaws
  - rated power 1,5 kW
  - speed range 5.000 - 24.000 rpm
  - torque 0,6 Nm (at 18.000 rpm)
  - rated voltage 220 V
  - manual tool changer
  - clamping range  $\varnothing$  0,5 - 10,0 mm
  - self ventilated at B side
  - connection M23
  - speed control by frequency converter
  - concentricity: 0,01 mm
  - weight: 4,4 kg
- optional
    - clamping block
    - frequency converter
    - brake resistor
    - exhaust system
    - range of different collets ER 16
    - various lengths of connection leads

## Technical specification

Description		HFS 1500
Torque at rated speed 24.000 U/min.	[Nm]	0,6
Speed	[rpm.]	5.000 ... 24.000
cut-off frequency	[Hz]	400
Number of poles		2
Rated voltage	[V]	220
Rated current	[A]	5,0
cos $\phi$		0,9
Rated power	[kW]	1,5
Concentricity	[mm]	0,01
Weight	[kg]	4,4

## Dimensioned drawings

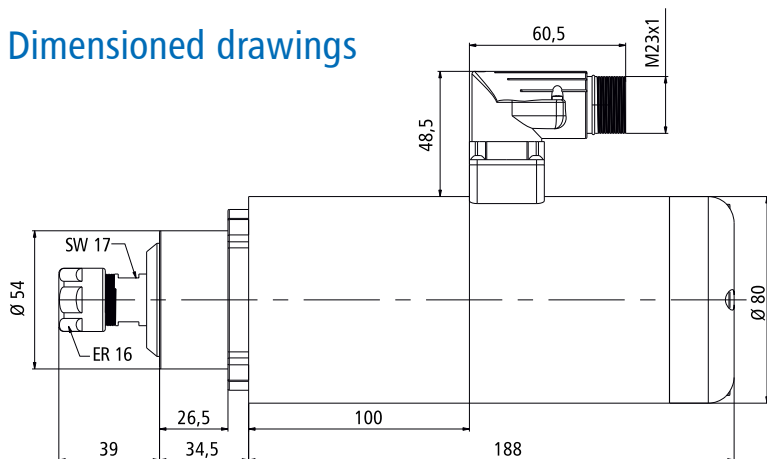

## Torque curves

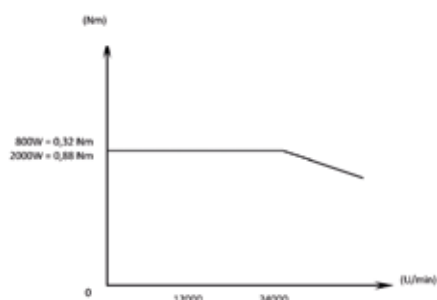

## Ordering information

### HFS 1500

Asynchronous spindle 1,5 kW  
with collet ER 16 (6 mm)

Part no.: **477015 3024**

### HFS 1500 with converter\*

with collet ER 16 (6 mm), connection lead 8 m

Part no.: **310815 2014**

### Hedy frequency converter

vector controlled, 1500 VA (1-phase)

Part no.: **311802 2000**

### Clamping set ER 16

1,0 / 2,0 / 3,0 / 4,0 / 5,0 / 6,0 / 7,0 / 8,0 / 9,0 / 10,0 mm

Part no.: **239171 0001**

### Clamping block SB 80

with slide nuts and screws

Part no.: **290904 0080**

\*converter pre-set for spindle

Technical specifications subject to change.



# High frequency spindle

## for manual tool changing

# HFS 2200



## Features

- solid 2-pole three-phase motor
  - round design
  - protection class IP 54, insulation class F, CE
  - motor shaft for holding ER 20 clamping jaws
  - rated power 2,2 kW
  - speed range 5.000 - 24.000 rpm
  - torque 0,88 Nm (at 24.000 rpm)
  - rated voltage 220 V
  - manual tool changer
  - clamping range  $\varnothing$  0,5 - 10,0 mm
  - self ventilated at B side
  - connection M23
  - speed control by frequency converter
  - concentricity: 0,01 mm
  - weight: 5,6 kg
- optional
    - clamping block
    - frequency converter
    - brake resistor
    - exhaust system
    - range of different collets ER 16
    - various lengths of connection leads

## Technical specification

Bezeichnung		HFS 2200
Torque at rated speed 24.000 U/min.	[Nm]	0,88
Speed	[rpm.]	5.000 ... 24.000
cut-off frequency	[Hz]	400
Number of poles		2
Rated voltage	[V]	220
Rated current	[A]	8,0
cos $\phi$		0,9
Rated power	[kW]	1,5
Concentricity	[mm]	0,01
Weight	[kg]	5,6

## Dimensioned drawings

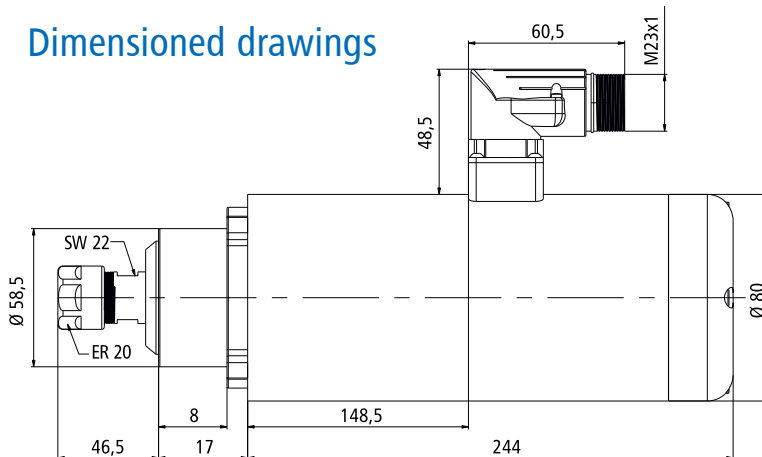

## Torque curves

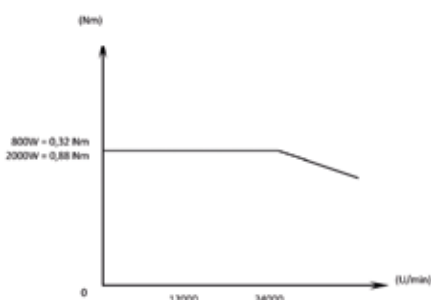

## Bestellangaben

### HFS 2200

Asynchronous spindle 1,5 kW  
with collet ER 20 (6 und 12 mm)

Part no.: **477022 30240**

### HFS 2200 with converter\*

with collet ER 20 (6 mm), connection lead 8 m Art.-Nr.:

Part no.: **310822 2014**

### Hedy frequency converter

vector controlled, 1500 VA (1-phase)

Part no.: **311802 2000**

### Clamping set ER 20

2,0 / 3,0 / 4,0 / 5,0 / 6,0 / 7,0 / 8,0 / 9,0 / 10,0 / 11,0 / 12,0 / 13,0 mm

Part no.: **239172 0001**

### Clamping block SB 80

with slide nuts and screws

Part no.: **290904 0080**

\*converter pre-set for spindle

Technical specifications subject to change.

# Dust extraction systems

in different versions

## iAG



Extraction devices iAG 720

### Area of application:

- individual workplace exhaust at machines and manual workstations
- free-flowing dusts (non-carcinogenic)
- dry dusts / blades
- hazardous to health dusts
- high blade / dust generation



### Features iAG 720

- low maintenance costs
- long life cleanable filter cartridges class M
- highly mobile unit fitted on movable castors combined with high extraction output
- tilt-back filter housing for ease of dust disposal
- suitable for most dust collection applications
- supplied complete with hose 80mm, L+5m adaptors and mounting clamps

### Specific characteristics:

- manual cleaning
- cleanable long life cartridge filters
- special versions supplied with modified filter cartridges to suit application
- vent connections (optional)
- special voltage on request
- floor cleaning kit and machine cleaning kit (optional)



Extraction devices iAG 600

### Area of application:

- individual workstation extraction for industrial and craft applications
- small mechanical workshops
- free – flowing dust / wood chips (non-carcinogenic)

### Features iAG 600

- suitable for small work areas
- ease of use
- cleanable, long life filter bags
- low operating costs
- supplied complete with hose 80mm, L+5m and mounting clamps

### Specific characteristics:

- cleanable filter bags cleaned with crank handle system
- special versions with filter cartridges air vent and power supply to suit application



Extraction devices iAG 200

### Area of application:

- direct individual workplace extraction
- free – flowing dust (non-carcinogenic)
- dry dust and wood chips
- low dust and wood chip volume

### Features iAG 200

- portable with multi-use applications
- compact, space-saving design
- cleanable, long life filter bags dust class M
- low operating costs
- supplied complete with hose 50mm, L+5m and mounting clamps

### Specific characteristics:

- integrated compressed air cleaning nozzle

## Accessories



Hose, length= 5m  
**Part-No. 639012 0004**  
 ... Ø 80 mm, for iAG 720 and iAG 600  
**Part-No. 639012 0005**  
 ... Ø 50 mm, for iAG 200



Mounting clamp  
**Part-No. 639012 0008**  
 ... up to 170 mm, for iAG 720 and iAG 600  
**Part-No. 639012 0007**  
 ... 40-60 mm, for iAG 200



Reduction  
 for iAG 720  
 (Ø 100 / 80 mm)  
**Part-No. 639012 0006**

Technical specifications subject to change.

# Dust extraction systems

in different versions

iAG

## Technical Data

Description		iAG 720	iAG 600	iAG 200
Voltage	[V]	230	400	230
Motor	[kW]	1.3	0.55	1.1
Max. negative pressure	[Pa]	2,800	1,400	19,000
Max. airflow	[m <sup>3</sup> /h]	720	600	200
Sound emission	[dB (A)]	73	68	66
Filter surface	[m <sup>2</sup> ]	3.5	1	0.8
Number of filter elements		1	1	1
Filter material		„M“-classified	„M“-classified	„M“-classified
Filter cleaning		manual brush cleaning	manual knock off appliance	Compressed air cleaning nozzle
Weight	[kg]	120	30	15
Intake diameter	[mm]	100	80	50
Dust collection bin	[Liter]	appr. 100	appr. 10	appr. 3
Dimensions L x W x H	[mm]	1,165 x 530 x 1,636	400 x 400 x 590	390 x 210 x 500
Part-No.		<b>239012 0030</b>	<b>239012 0032</b>	<b>239012 0031</b>

## Dimensioned drawings

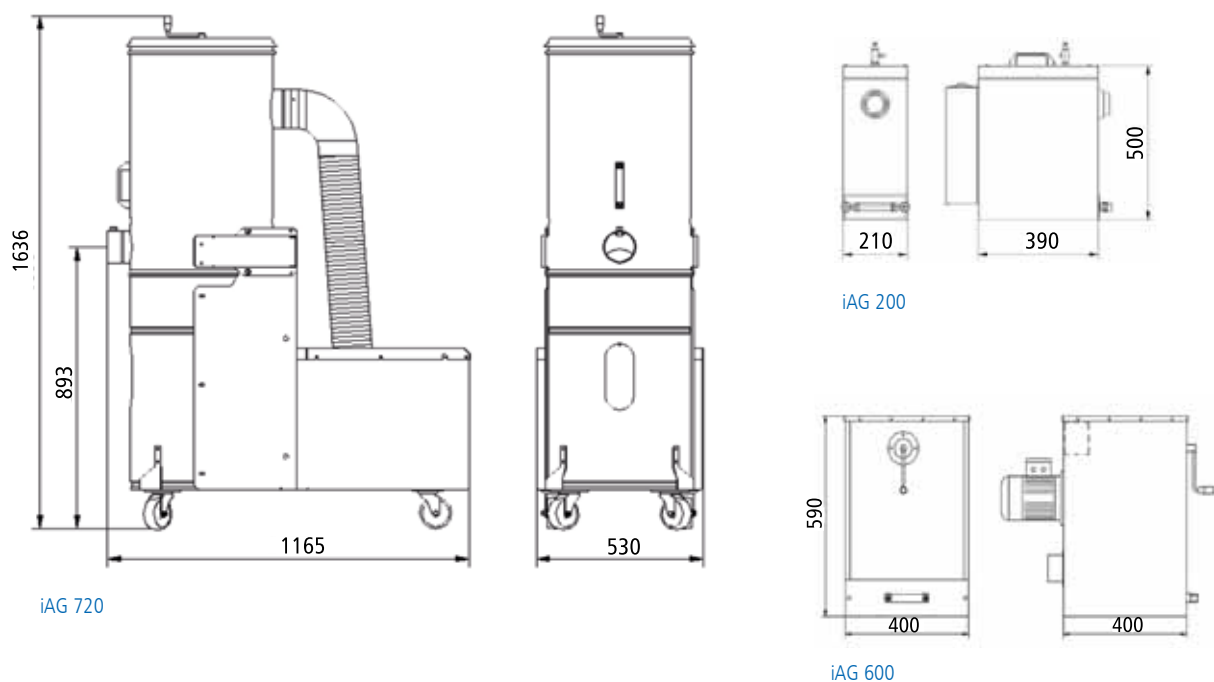

Technical specifications subject to change.

# Tool cooling system

## COOLMin

### Functional principle

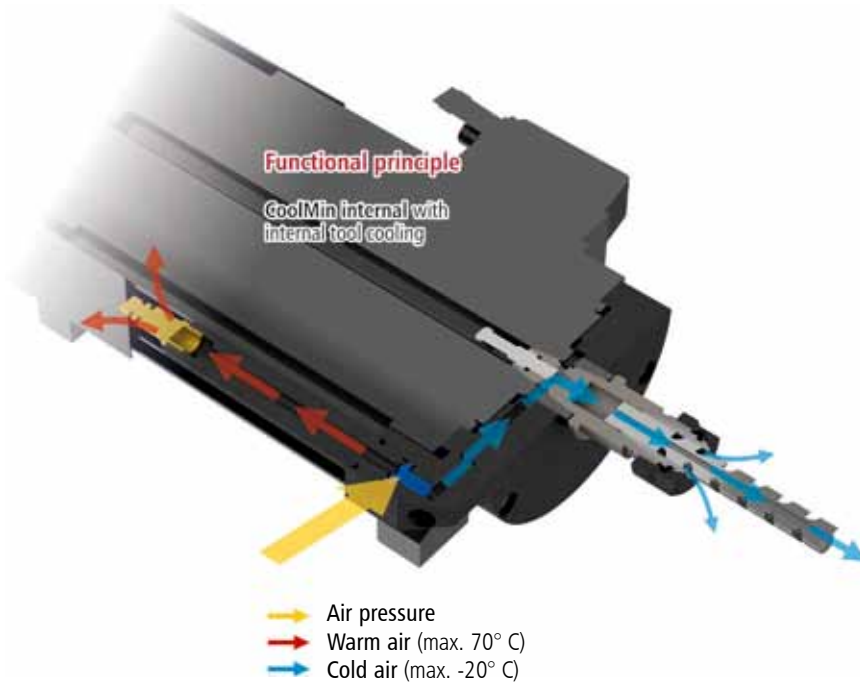

- 1 Spindle motor
- 2 Temperature controller
- 3 Hot air exhaust
- 4 Vortex nozzle with cold air exhaust
- 5 Compressed air feed
- 6 Cold air blower in synthetic material
- 7 Tool holder for internal cooling
- 8 Milling cutter for internal cooling



### Tool and material cooling

Dry cutting is today the first choice for many machining tasks.

Hitherto, materials, tool wear and surface finish have often necessitated cooling with appropriate coolants / greases. This always means moisture. Even minimal moisture spray cooling causes unwanted effects such as the build-up of dirt and the adhesion of swarf to the cutting tool or to the working surface and can lead to the deterioration of the material surface structure, depending on the material being machined.

Our patented cooling method ensures adequate tool and surface cooling and reduces such effects to negligible levels. This keeps the swarf dry and, depending on the material, easy to remove by either blowing or vacuuming. Surfaces are therefore protected and, as a result of direct tool cooling, tool life is significantly increased (also suitable for tools with integrated cooling).

The main component of our cooling method is a cold air nozzle, which operates on the eddy current principle and separates warm air from cold.

The system is powered by air pressure alone (6 to 10 bar).



Tool, cooled by CoolMin internal

Technical specifications subject to change.

# Tool cooling system

**COOLMin**

## Functional principle

### CoolMin external

### CoolMin internal without tool cooling system

- 1 Compressed air feed
- 2 Flexible mating hose
- 3 Spindle motor
- 4 Temperature controller
- 5 Hot air exhaust
- 6 Vortex nozzle with Cold air exhaust
- 7 Cold air supply in synthetic material
- 8 Collet



**Diagram:**  
CoolMin external with mating hose



**Diagram:**  
CoolMin internal



**Diagram:**  
Optimum cold air flow (up to -25°C) for tool cooling and chip evacuation

## Technical specification

Compressed air feed	6 – 10 bar
Cold air exhaust	up to max. -25° C
Hot air exhaust	up to max. 70° C
Air consumption	approx. 150 l/min.

## Ordering information

Description		Part number
CoolMin external	with mating hose, incl. servicing kit and shut-off tap (manual)	239011 0119
CoolMin external	incl. servicing kit and electrically-powered valve	239011 0117
CoolMin internal		see individual motors

Technical specifications subject to change.

# Linear tool change stations

## SK 11 / 20 / 30

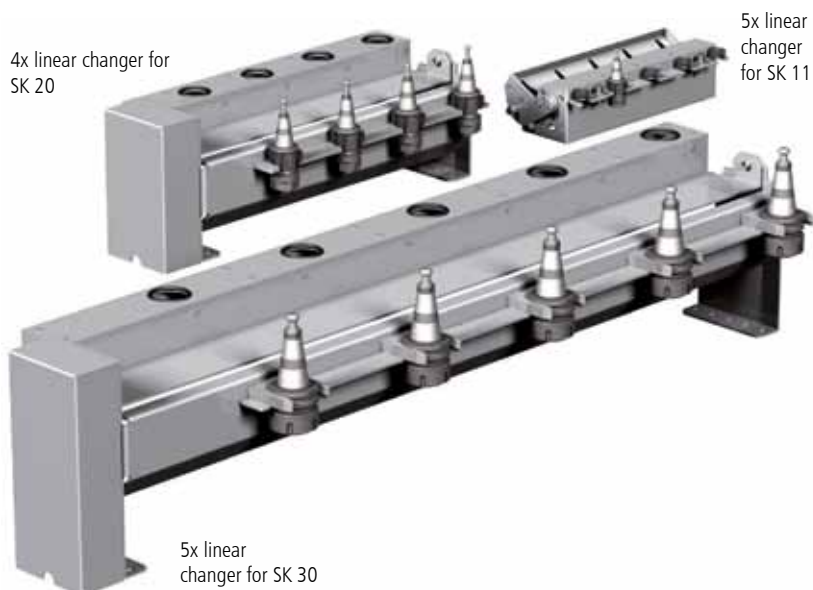

### Features

- simple, functional tool changer for SK 11, SK 20 and SK 30
- pneumatic rotary cylinder and end position monitoring for safe changing
- control via 5/2-way valve with integration in the safety circuit
- low-maintenance, stainless steel design (powder-coated aluminium)
- variable positioning on the machine bench

### Ordering information

#### SK 11 tool change station

...for iSA 900

5x, with hood + pneumatics  
Part-no.: **239011 0053**

8x, with hood + pneumatics  
Part-no.: **239011 0083**

#### SK 20 tool change station

...for iSA 2200

4x (in steps of 100mm),  
with hood + pneumatics  
Part-no.: **239011 0041**

8x (in steps of 100mm),  
with hood + pneumatics  
Part-no.: **239011 0081**

5x (in steps of 170mm),  
with hood + pneumatics  
Part-no.: **239011 0050**

10x (in steps of 170mm),  
with hood + pneumatics  
Part-no.: **239011 0100**

#### SK 30 tool change station

...for iSA 3600

4x, with hood + pneumatics  
Part-no.: **239011 0045**

5x, with hood + pneumatics  
Part-no.: **239011 0055**

8x, with hood + pneumatics  
Part-no.: **239011 0082**

### Tool holders



SK 11

SK 20

SK 30

SK 11 for collets Type ER 11  
Part-no.: **239111 0001**

SK 20 for collets Type ER 20  
Part-no.: **239172 0020**

SK 30 for collets Type ER 32  
Part-no.: **239130**

Collets see page **E-44**.

### Length measurement sensor



Length measuring sensor  
for measuring tool lengths  
Part no.: **239099 0001**

Technical specifications subject to change.

# Linear tool change stations

# SK 11 / 20 / 30

## Dimensioned drawings

Tool change stations SK 11

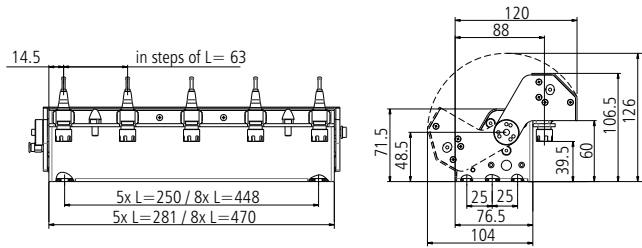

Tool change stations SK 20

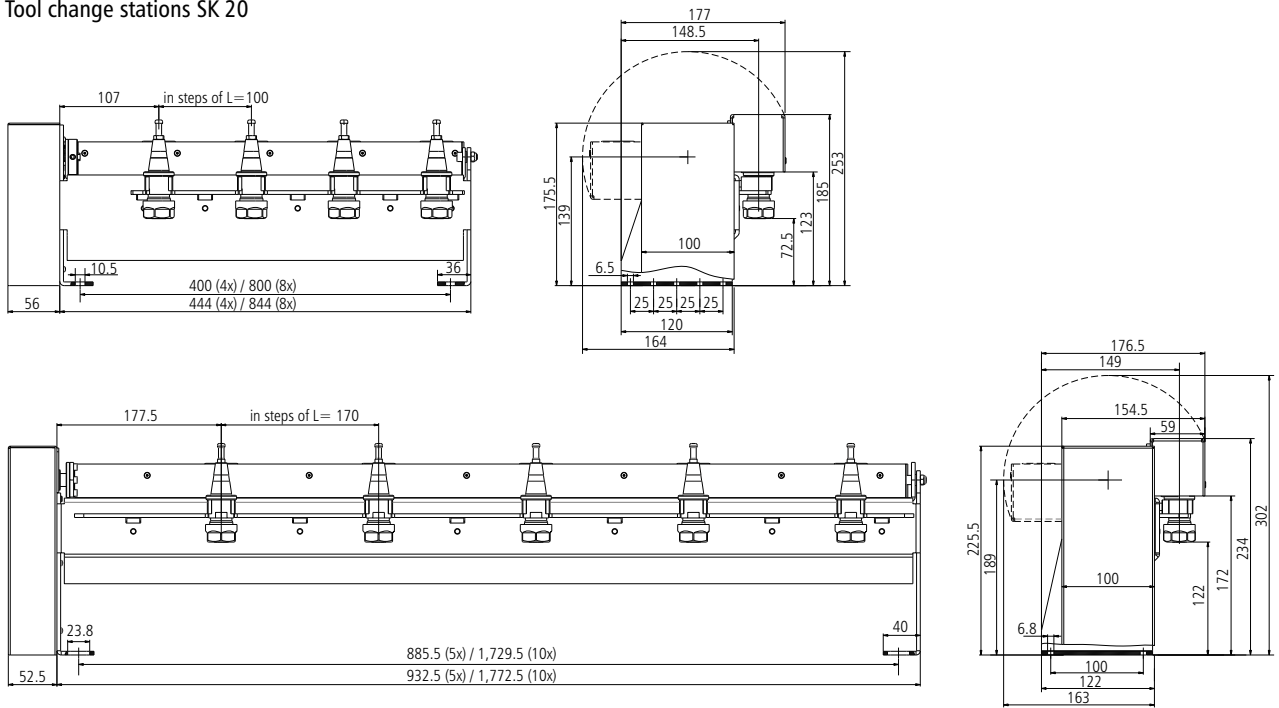

Tool change stations SK 30

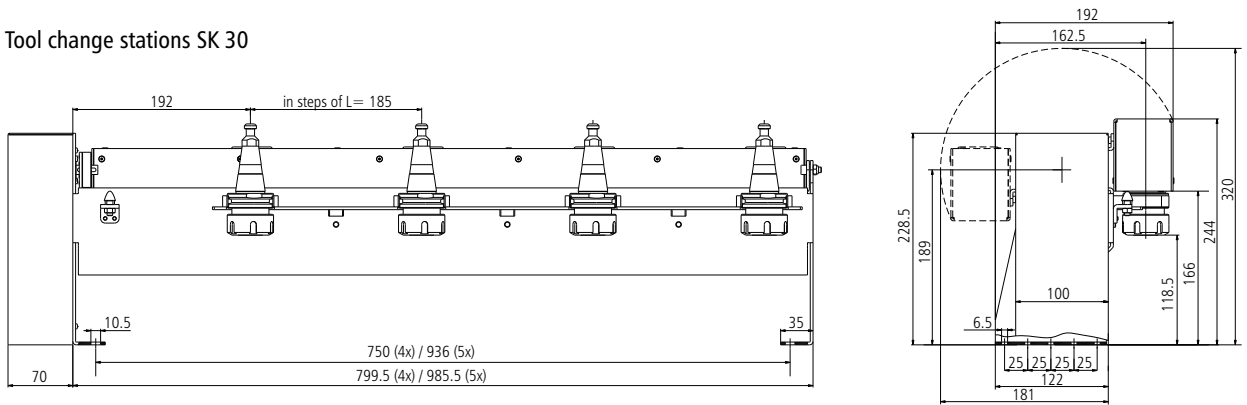

Technical specifications subject to change.

# Turned tool change stations

## SK 11 / 20



Interesting application videos can be found on our YouTube channel. Just take a look!

### Features

- compact, space-saving design by circular tool positions
- powder-coated aluminium housing (RAL 3011)
- integrated power electronics for controlling via isel CNC commands via RS232 interface
- monitored tool positions and tool opening via sensors
- linear movement of the tool holder and the opening changer via switchable solenoid valves (5/2-way valve)
- used on all common isel Servo CNC machines
- easy to service

### Dimensioned drawings

Turned tool change station SK 11

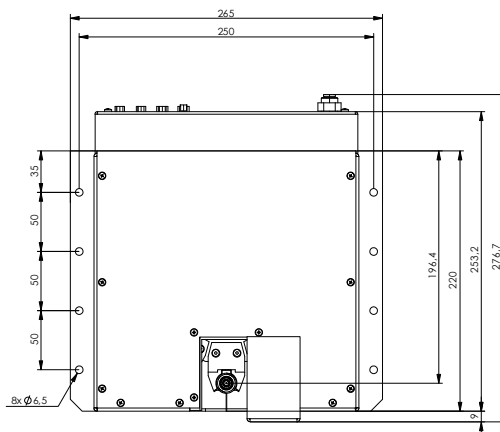

View from above

Turned tool change station SK 20

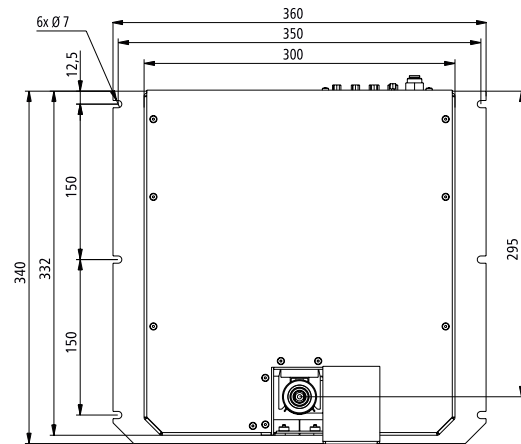

View from above

### Technical data and ordering information

	turned tool change station SK 11	turned tool change station SK 20
Tool places	12	14
max. tool length [mm]	60	75
min.gap height [mm]	250	350
Suitable spindle motor	ISA 900	ISA 2200
Interface	RS 232	
Supply voltage	+24 VDC	
Dimensions W x D x H [mm]	265 x 277 x 224	360 x 340 x 271
Part-no.	239100 0030	239100 6630

Technical specifications subject to change.



# Motor leads and dust extraction devices

## Motor leads



- 8-wire (3x 0.75 mm<sup>2</sup> + 1x PE + 2x(2 × 0.34 mm<sup>2</sup>))
- drag chain compatible
- external braiding and separately shielded pairs
- pre-fabricated

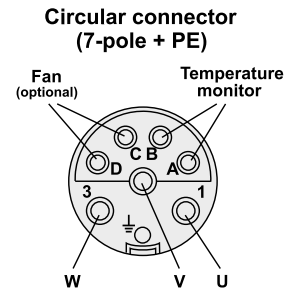

Motor side - M23 plug  
 Converter side - wire end bushings  
 Part no.: **392306 0300** (3 m)  
 Part no.: **392306 0500** (5 m)  
 Part no.: **392306 0800** (8 m)

Motor side - direct connection  
 Converter side - wire end bushings  
 Part no.: **392301 0300** (3 m)  
 Part no.: **392301 0500** (5 m)  
 Part no.: **392301 0800** (8 m)

Section	Wire	Wire Cross	Frequency converter
Motor connection	SW 1	0.75 mm <sup>2</sup>	U
	SW 2	0.75 mm <sup>2</sup>	V
	SW 3	0.75 mm <sup>2</sup>	W
	green / yellow	0.75 mm <sup>2</sup>	PE
Separately driven fan	green	0.34 mm <sup>2</sup>	L1
	yellow	0.34 mm <sup>2</sup>	L2 / N
Temperature monitoring	brown	0.34 mm <sup>2</sup>	T1
	white	0.34 mm <sup>2</sup>	B7

## Dust extraction devices



Description	for spindle motor	Part-no.	
Extraction device	iSA 500 / 750	prepared for hose 38 mm, manual opening	239012 0000
	iSA 900	prepared for hose 50 mm, manual opening	239012 0004
	iSA 1500	prepared for hose 80 mm, manual opening	239012 0001
	iSA 1500L	prepared for hose 80 mm, manual opening	239012 0009
	iSA 2200	prepared for hose 80 mm, automatic opening	239012 0002
		with external CoolMin, prepared for hose 80 mm, automatic opening	239012 0003
	iSA 3600	prepared for hose 80 mm, automatic opening	239012 0005
		with external CoolMin, prepared for hose 80 mm, automatic opening	239012 0006
Extraction head	iSA 500	prepared forexternal CoolMin, prepared for hose 50 mm, manual opening	239012 0013
	iSA 750	prepared for external CoolMin, prepared for hose 50 mm, manual opening	239012 0012

Technical specifications subject to change.

# Collets for iSA-series



ER 11

ER 16

ER 20

**Collets**  
for HSD-series  
see page E-32

**Collet set**  
for HFS-series  
see pages E-33, E-34, E-35

The following collets are also able to clamp shafts reduced in diameter by 0.5 mm:

## Collets type ER 11

for iSA 500 and iSA 900

Ø (mm)	Part no.
1,0	239170 1000
1,5	239170 1500
2,0	239170 2000
2,5	239170 2500
3,0	239170 3000
3,5	239170 3500
4,0	239170 4000

Ø (mm)	Part no.
4,5	239170 4500
5,0	239170 5000
5,5	239170 5500
6,0	239170 6000
6,5	239170 6500
7,0	239170 7000

## Collet set

for spindle motor	Type	Ø (mm)	Part no.
iSA 500/iSA 900	ER 11	1.0 - 7.0	239170 0001

## Clamping nuts

Type	Part no.
ERM 11	239170
ERM 16	239171
ERM 20	239172

The following collets are also able to clamp shafts reduced in diameter by 1.0 mm:

## Collets type ER 16

for iSA 750

Ø (mm)	Part no.
1.0	239171 1000
2.0	239171 2000
3.0	239171 3000
4.0	239171 4000
5.0	239171 5000
6.0	239171 6000
7.0	239171 7000
8.0	239171 8000
9.0	239171 9000
10.0	239171 0100

## Collets type ER 20

for iSA 1500 and iSA 2200

Ø (mm)	Part no.
2.0	239172 2000
3.0	239172 3000
4.0	239172 4000
5.0	239172 5000
6.0	239172 6000
7.0	239172 7000
8.0	239172 8000
10.0	239172 0100
11.0	239172 0110
12.0	239172 0120
13.0	239172 0130

## Collets type ER 32

for iSA 3600

Ø (mm)	Part no.
3.0	239130 3000
4.0	239130 4000
5.0	239130 5000
6.0	239130 6000
7.0	239130 7000
8.0	239130 8000
9.0	239130 9000
10.0	239130 0100
11.0	239130 0110
12.0	239130 0120
13.0	239130 0130
14.0	239130 0140
15.0	239130 0150
16.0	239130 0160
17.0	239130 0170
18.0	239130 0180
19.0	239130 0190
20.0	239130 0200

## Collet sets

for spindle motor	Type	Ø (mm)	Part no.
iSA 750	ER 16	1.0 - 10	239171 0001
iSA 1500 / iSA 2200	ER 20	2.0 - 13	239172 0001
iSA 3600	ER 32	3.0 - 20	239130 0000

Technical specifications subject to change.

# Vacuum clamping plates

**VAKUFIT®**

## Sample diagram



Multiple connections for high volume flow and optimal vacuum distribution.



All our vacuum plates can be arranged to fit together to cover large areas.

Other dimensions up on request.

Part number	Description	DIN	Clamping surface
<b>216601 0017</b>	VT 2115	A5	210 x 150 mm
<b>216601 0018</b>	VT 3021	A4	300 x 210 mm
<b>216601 0019</b>	VT 4230	A3	420 x 300 mm
<b>216601 0020</b>	VT 6042	A2	600 x 420 mm
<b>216601 0030</b>	Rotary vane pump (10.0 m <sup>3</sup> /h) for DIN A4 und A5		
<b>216600 0028</b>	Servicing kit for rotary vane pump 10.0 m <sup>3</sup> /h		
<b>216601 0010</b>	Connection set vacuum plate to rotary vane pump		
<b>616601 2115</b>	Rubber matting for vacuum plates A5		
<b>616601 3021</b>	Rubber matting for vacuum plates A4, T=1 mm, QTY 1 piece		
<b>616601 3022</b>	Rubber matting for vacuum plates A4, T=3 mm, QTY 5 piece		
<b>616601 3023</b>	Rubber matting for vacuum plates 1200 x 900 mm		

Technical specifications subject to change.

## VakuFit - L

The raster plates for the vacuum clamping makes little demand on the vacuum pump. The plates are almost totally warp free and the material is therefore suitable for engraving operations when clamped.

In contrast to other vacuum clamping methods, surfaces can be milled over large areas without problem, with parts remaining securely clamped.

Material stops can be easily effected by inserting 5 mm dowelling pins into the raster plate holes. The board rubber matting is a consumable with a variety of uses. In addition to our standard plates, we offer customised variants and complete plate packages for special applications.

## Note

Retaining force is proportional to the area covered, the coefficient of friction and the differential pressure.

In order to increase the coefficient of friction, rubber matting is included within the scope of delivery.

## Scope of delivery

- 1x connection adapter
- 1x screw key 68 mm
- 1x rubber matting for holes
- 1x rubber matting for covering unused holes
- Operating instructions

# Coolant misting system



## Coolant misting system Features

- electro-pneumatically controlled
- plastic container, capacity 1 liter, including valve unit
- rotary throttle valves for reproducible fine adjustment of the medium and spray air volume
- coaxial spraying head which generates a round 15° spray angle
- includes a 4 m hose for each medium and spray air, as well as 300 mm ball joint extension

## Minimum volume coolant misting system Features

- aluminium pressure vessel
- with 1 or 2 adjustable nozzles, includes 1 liter of spray oil
- liquid level control
- valve unit with solenoid valves
- precision coaxial spray head
- ball joint extension
- nozzle connection package with fittings for medium and spray air
- pressure reducer to adjust the container pressure

## Ordering information

Description		Part-no.
Coolant misting system	with flexible nozzle, 24 V, includes container and 1 l spray oil	429111 1000
Minimum volume coolant misting system	with one flexible nozzle, includes 1 l spray oil	429116 1000
	with two flexible nozzle, includes 1 l spray oil	429116 2000

Space for your notes

# Robotik



As a division within isel Germany AG , isel Robotik presents a cross-section of its product portfolio of automation components for robots, wafer-handler, prealigners, linear units, end effectors and accessories for the semiconductor industry, made in Germany. The company's Robotics Division has been operating for more than 10 years within the semiconductor sector. Sales began in 2004 with just a few types of robot and prealigner. Today the range of components for the semiconductor industry covers the needs of all OEM customer within the semiconductor sector. Since 2004, over 1000 robot systems have been successfully put into service. For these processes, in addition to clean room compatibility, high precision and reliability are paramount. Since these requirements affect the entire production process in the chip industry, stringent specifications also apply with regard to component handling. Handling components exemplify isel Germany's market reputation: very high quality, short delivery times, the best possible service and a very good price-performance ratio. Ask for an appointment with one of our applications engineers. We look forward to your visit and an opportunity to serve your automation, robotic and handling needs.

#### Sales and consultancy

phone: +49(0) 6659 / 981-790  
 telefax: +49(0) 6659 / 981-776  
 Email: iselrobotikeurope@isel.com

Thomas Völlinger (Divisional sales manager)  
 Sabrina Och (Team assistant)

#### Customer support

phone: +49(0) 6659 / 981-790  
 telefax: +49(0) 6659 / 981-776  
 Email: robotik-service@isel.com  
 Michael Raschke

#### Customer support hotline

phone: +49(0) 6659 / 981-756

Visit us under [www.iselrobotik.com](http://www.iselrobotik.com)

# Robotik

**We're there for you...**

**...because you'll get it all from one source**

Because we control all aspects of our products life cycle, from design, production, sales and service, we ensure you will receive competent contacts for all questions concerning our products.

**...with more than 40 years of market presence**

Supporting iselRobotik department is the renowned and internationally-active isel Germany AG. Benefit from our market presence of many years in a variety of industry lines.

**...in the heart of Europe**

Our location in Eichenzell (Hesse) in central Germany is close to Europe's semiconductor key locations.



Visit us under [www.iselrobotik.com](http://www.iselrobotik.com)



Wafer Handling Roboter



Controller & Software



End effectors



Linear Track



Prealigner

# Index

## A

Accessories (CNC machines)	E-22 – E-45
Accessories (LEZ linear units)	B-70
Aluminium rotating plate	B-74
Aluminium slide WS 1	B-8
Aluminium slide WS 3	B-10
Aluminium slide WS 4	B-18
Aluminium slide WS 6	B-16
Aluminium slide WS 7	B-20
Aluminium slide WS 8	B-22
Angle bracket	B-58 – B-60
Angular transmission	B-52
Aluminium profiles	B-2

## B

Ball screw spindles	B-28
Ball screw nuts	B-30, B-32
Block diagram KG drives	B-26

## C

CAN-CNC controller	C-9
Chassis (flatbed units)	E-18
Chuck assembly	B-74, B-76, B-78, B-82, B-80
Clamping blocks	B-31
Clamping nuts	E-44
Clutches	B-48
CNC control units iOP-19	C-3
Collet housings	B-82, B-80
Collets	E-44
Cooling/spray device	E-17
CoolMin	E-38
CoolMin tool cooling system	E-38
Cross bench connection plates	B-56

## D

Drive elements overview	B-26
Dual track set	B-22
Dust extraction systems	E-36
Dust extraction devices	E-43

## E

Energy guidance chain	B-61
EuroMod	E-12

## F

Flange bearing	B-33
Flatbed unit FB2	E-18
FlatCom XL	E-10

## G

Gas pressure spring	B-61
---------------------	------

## H

High frequency spindle HFS 800	E-33
High frequency spindle HFS 1500	E-34
High frequency spindle HFS 2200	E-35
Housing (flatbed units)	E-18

## I

ICP 4030	E-16
iCU-DC / iCU-EC	C-8
ICV 4030	E-14
iMC-S8	C-5
iOP-19	C-3
iPU power unit	C-7
iPU-DC/iPU-EC	C-7
iSA 500	E-24
iSA 750	E-25
iSA 900	E-26
iSA 1500	E-27
iSA 1500 L	E-28
iSA 1500 WL	E-29
iSA 2200	E-30
iSA 3600	E-31
isy <sup>®</sup> CAM 2.8	D-4
IT 116 Flash	C-4

## L

Length measurement sensor	E-40
LES 4	B-38
LES 5	B-42
LES 6	B-40
LES combination examples	B-44
LES functional overview	B-36
LES motor modules	B-46
LEZ 1	B-64
LEZ 2	B-66
LEZ 3	B-68
LEZ angle bracket	B-70
LEZ combination examples	B-71
LEZ functional overview	B-62
LEZ motor modules	B-65, B-67, B-69
LFS-12-1	B-14
LFS-12-10	B-22
LFS-12-11	B-16
LFS-12-2	B-18
LFS-12-3	B-20
LFS-8-1	B-8



# Index

LFS-8-2	B-8	Trolley LW 2	B-20
LFS-8-3	B-10	Trolley LW 3	B-14, B-18
LFS-8-4	B-12	Trolley LW 4	B-22
Limit switches	B-61	Trolley LW 5	B-16
Linear guide slides function	B-6	Trolley LW 6	B-8
Linear guides overview	B-4	Trolley LW 7	B-10, B-12
Linear units overview	B-34	Trolley LW 8	B-20
<b>M</b>			
MC 1-20 / MC 1-40	C-6	<b>V</b>	
MD 1	B-82	Vacuum clamping plates	E-45
Motor mounting plate	B-70	Vacuum cleaning	E-43
Motor leads	B-51	<b>W</b>	
Motor pin assignments	B-50, B-84	Workspace lighting	E-17
Multiple axis controller	C-5, C-7	<b>Z</b>	
<b>O</b>			
OverHead Gantry	E-8	ZD 30	B-80
<b>P</b>			
Plastic nuts	B-29		
ProNC	D-7		
<b>R</b>			
RDH-M	B-74		
RDH-S	B-76		
RDH-XS	B-78		
Remote	D-6		
ROBOTICS	E-48		
Rotation units overview	B-72		
<b>S</b>			
Shaft housing blocks	B-14		
Shaft slides	B-70		
Single axis controller	C-4, C-6		
SK 11/20/30	E-40, E-42		
Slide plates	B-54, B-56		
Software and controller organisation	D-2		
Spindle motors	E-22 – E-35		
Steel slide LS 1	B-14		
Step controller	C-4, C-5		
Systems overview	E-7		
<b>T</b>			
Tailstock units	B-74, B-76, B-78, B-80		
T-slot slide plates	B-57		
Tool changing stations	E-40 - E-42		
Tool holders	E-40		
Transmission shaft	B-52		
Transport loads (rotation units)	B-85		



Our general terms and conditions as well as terms of use for software can be found at [www.isel.com](http://www.isel.com)





MECHANICS



ELECTRONICS



SOFTWARE



SYSTEMS



DISPLAY



LIFESTYLE

## PROGRAM OF THE **isel**-GROUP

development, production and sales of components and systems in the sectors **mechanics, electronics, software, systems, display and lifestyle**

### **isel**GermanyAG

Bürgermeister-Ebert-Straße 40  
D-36124 Eichenzell  
Phone: +49 (0) 66 59 / 981 - 700  
E-Mail: [automation@isel.com](mailto:automation@isel.com)  
[www.isel.com](http://www.isel.com)

### **isel**France

ZAC de la Prévauté  
4, Rue des Côtes d'Orval BP 41  
F-78550 Houdan  
Phone: +33 (0) 130 461 201  
E-Mail: [info@isel.fr](mailto:info@isel.fr)  
[www.isel.com/fr](http://www.isel.com/fr)

### **isel**UK

isel UK Ltd. | Unit 17 | Maylands Business Centre  
Redbourn Road  
Hemel Hempstead | HP2 7ES | United Kingdom  
Phone: +44 (0) 1442 531 225  
E-Mail: [info@isel-uk.com](mailto:info@isel-uk.com)  
[www.isel.com/uk](http://www.isel.com/uk)

### **isel**Austria

isel Austria GmbH & Co. KG  
Maria Theresia-Str. 53 / 1.1  
4600 Wels / Austria  
Phone: +43 (0) 72 42 / 20 68 29  
E-Mail: [info@isel-austria.com](mailto:info@isel-austria.com)  
[www.isel.com/en](http://www.isel.com/en)

### **isel**Hungária

isel Hungaria Kft.  
József A. utca 38  
H-8200 Veszprém  
Phone: +36 (0) 88 568 030  
E-Mail: [iselhungaria@isel.hu](mailto:iselhungaria@isel.hu)  
[www.isel.com/hu](http://www.isel.com/hu)

### **isel**USA

isel USA, Inc. | 69 Bloomingdale Road  
USA, Hicksville, New York 11801  
Phone: 001-516-595-7497  
E-Mail: [George.klein@isel.com](mailto:George.klein@isel.com)  
[Joseph.Griffin@isel.com](mailto:Joseph.Griffin@isel.com)  
[www.isel.com/en](http://www.isel.com/en)