

Clamping blocks For nut version 3

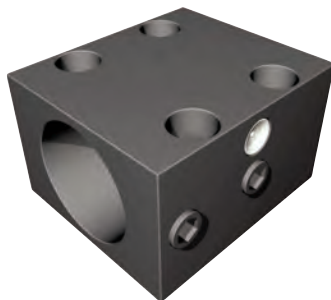

Flange securing



Base securing

Features

- Material steel, gunmetal finish
- Versions for recirculating ball spindles \varnothing 25 and \varnothing 16 mm
- Nut pitches
5 / 10 and 20 mm (\varnothing 25 mm)
2.5 / 4 / 5 / 10 and 20 mm (\varnothing 16 mm)
- Recirculating ball nuts are adjustable for no play
- Clamping blocks for base and flange securing

Ordering information

Clamping block 2 \varnothing 16
Flange securing

Pitch	Part no.
all	213 501

Clamping block 1 \varnothing 16
Base securing

Pitch	Part no.
all	213 500

Clamping block 2 \varnothing 25
Flange securing

Pitch	Part no.
5 / 10	213 700 9003
20	213 700 9004

Clamping block 1 \varnothing 25
Base securing

Pitch	Part no.
5 / 10	213 700 9001
20	213 700 9002

Dimensioned drawings – spindle clamping blocks \varnothing 16

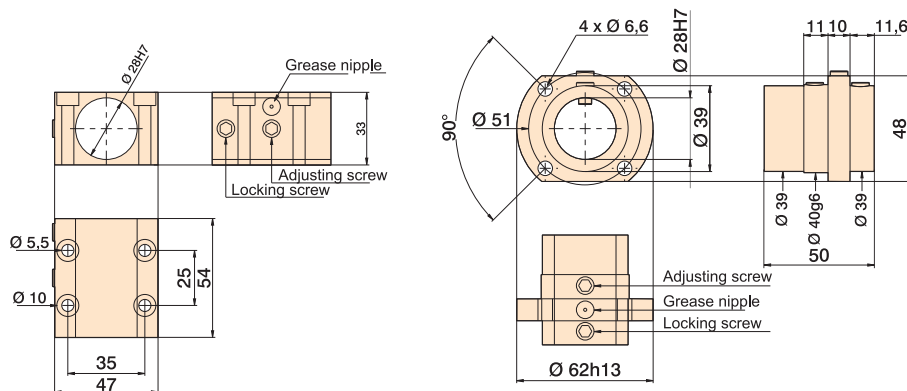

Dimensioned drawings – spindle clamping blocks \varnothing 25

