

JL4 Servo Motors

Drives



JetWeb

Installation Manual



Edition 2.05

Jetter AG reserves the right to make alterations to its products in the interest of technical progress. These alterations need not to be documented in every single case.

This manual and the information contained herein have been compiled with due diligence. Jetter AG shall not be liable for errors contained herein or for incidental or consequential damage in connection with the furnishing, performance, or use of this material.

The brand names and product names used in this manual are trade marks or registered trade marks of the respective title owner.

How to Contact us:

Jetter AG
 Gräterstraße 2
 D-71642 Ludwigsburg
 Germany

Phone - Switchboard: 07141/2550-0
 Phone - Sales: 07141/2550-433
 Phone - Technical Hotline: (+49) 7141/2550-444

Fax: (+49) 7141/2550-425
 E-Mail - Sales: sales@jetter.de
 E-Mail - Technical Hotline: hotline@jetter.de
 Internet address: http://www.jetter.de

This installation manual is an integral part of the JL4 servo motor series:

Type: _____
 Serial No: _____
 Year of construction: _____
 Order No.: _____



To be entered by the customer:

Inventory #: _____
 Place of operation: _____

© Copyright 2006 by Jetter AG. All rights reserved.

Significance of this Installation Manual

This installation manual is an integral part of the JL4 synchronous servo motor series

- and must be kept in a way that it is always at hand until the motor of the JL4 synchronous servo motor series will be disposed of.
- If the motor of the JL4 synchronous servo motor series is sold, alienated or loaned, this manual must be handed over.

In any case you encounter difficulties to clearly understand this installation manual, please contact the manufacturer.

We would appreciate any kind of suggestion and contributions on your part and would ask you to inform us or to write us. This will help us to produce manuals that are more user-friendly and to address your wishes and requirements.

This installation manual contains important information on how to transport, erect, install, operate, maintain, and repair the motors of the JL4 synchronous servo motor series.

Therefore, this person must carefully read, understand and observe this manual, and especially the safety instructions.

Missing or inadequate knowledge of the manual results in the loss of any claim of liability on part of Jetter AG. Therefore, the operating company is recommended to have the instruction of the persons concerned confirmed in writing.

History

2.03	Original issue in English
2.04	Alterations as listed in appendix A (edition 2.04)
2.05	See Appendix A: "Recent Revisions", page 52

Description of Symbols



Danger

This sign is to indicate a possible impending danger of serious physical damage or death.



Caution

This sign is to indicate a possible impending danger of light physical damage. This sign is also to warn you of material damage.



This sign indicates hazard of life due to electric shock caused by a high operating voltage.



This sign is to indicate hazard of serious physical damage or death due to accidentally touching dangerous parts of the device.



You are asked to wear goggles. Failure to comply may lead to bodily injuries.



This sign is to warn you of material damage due to applying hard blows or shocks to the motor flange and shaft.



Important!

This sign is to indicate a possible impending situation which might bring damage to the product or to its surroundings. This symbol also points to conditions, which must by all means be given heed to, in order to guarantee faultless functioning.

**Note!**

You will be informed of various possible applications and will receive further useful suggestions.

Further, it points to tips and advice for efficient use of the device and for optimization of the corresponding software, in order to save you extra work.



Enumerations are marked by full stops, strokes or scores.



Operating instructions are marked by this arrow.



Automatically running processes or results to be achieved are marked by this arrow.



Illustration of PC and user interface keys.



This symbol refers to further information (data sheets, literature, etc.) on the subject or product or the like that is being dealt with. Further, this text provides helpful hints for your guidance through the manual.

Table of Contents

1	Safety Instructions	9
1.1	General Information	9
1.1.1	Usage as Agreed Upon	9
1.1.2	Usage other than agreed upon	10
1.1.3	Who is permitted to operate the JL4 servo motor?	10
1.1.4	Modifications and alterations to the motor	10
1.1.5	Repairing and servicing the JL4 servo motor	10
1.1.6	Decommissioning and disposing of the JL4 servo motor	11
1.2	Ensure your Own Safety	11
1.2.1	Malfunctions	11
1.2.2	Information signs and labels	12
1.2.3	Earthing procedure	12
1.2.4	Activating the holding brake without endangering persons	12
1.3	Residual Dangers	13
1.3.1	Hazards during operation	13
1.3.2	Hazards after POWER has been turned OFF	15
1.4	Instructions on EMI	15
2	Installation of the Servo Motor	17
2.1	Scope of Delivery	17
2.2	Important Remarks	18
2.2.1	Ambient conditions	18
2.2.2	Avoiding damages	19
2.3	Mechanical Installation	21
2.4	Electrical Installation	23
2.5	Checking the Installation	24
2.6	Notes on Safety as regards the Installation	25
2.7	Safety Instructions for Commissioning	26
3	Operating Conditions	27
4	Type Designation	28
5	Physical Dimensions	30
6	Technical Data	31
7	Description of Connections	36
7.1	Motor Connection by means of the Motor Connector Series SC	36
7.1.1	General remarks	36
7.1.2	Motor power cable with mating connector	37

7.1.3	Motor power cable for JetMove 2xx	38
7.1.4	Motor power cable for JetMove 6xx	40
7.1.5	Connection assignment of terminal box	42
7.2	Connection of the Resolver	43
7.2.1	Motor power cable with mating connector	43
7.2.2	Resolver cable for JetMove 2xx	44
7.2.3	Resolver cable for JetMove 6xx	45
7.3	HIPERFACE Connection	46
7.3.1	HIPERFACE cable with mating connector	46
7.3.2	HIPERFACE cable for JetMove 2xx	47
7.3.3	HIPERFACE cable for JetMove 6xx	48
8	Maintenance of the Motor	49
9	Troubleshooting	50

List of Appendices

Appendix A:	Recent Revisions	52
Appendix B:	Glossary	53
Appendix C:	Index of Illustrations	56
Appendix D:	Index	57

1 Safety Instructions

1.1 General Information

The JL4 synchronous servo motor series JL complies with the safety regulations and standards in force. Special emphasis was given to the safety of the users.

The following additional regulations apply to the user:

- relevant accident prevention regulations;
- accepted safety rules;
- EC guidelines and other country-specific regulations.

1.1.1 Usage as Agreed Upon

Usage as agreed upon includes operation in accordance with this installation manual.

The JL4 series of synchronous servo motors belongs to the category of brushless permanently excited precision motors of sine-shaped induced voltage.

The JL4 synchronous servo motors have explicitly been designed for being torque, speed, and/or position controlled by specific servo amplifiers, such as JetMove xxx made by Jetter AG. This motor has not been designed for direct connection to the three-phase supply network. Direct connection to the mains will result in destruction of the motor.

The JL4 synchronous servo motor series may only be operated within the limits of the stated data, see chapter 6 "Technical Data", page 31.

The AC rated voltage of the motors is 170 V, respectively 310 V. The winding insulation of the motors is rated at 560 V; this means that the DC link voltage of the servo amplifier can amount up to DC 560 V. Thus, the motor is subject to the EC Low Voltage Directive.

The JL4 synchronous servo motor series has especially been designed as a drive for machines that put high demands on dynamic performance and endurance. The JL4 servo motors may **only** be run under the operating conditions specified in this installation manual; see chapter 3 "Operating Conditions", page 27.

The JL4 synchronous servo motors are installed in machines; they may only be commissioned as devices integrated in specific plants.

The values rendered by the thermo protection element that is integrated into the motor windings must be evaluated and monitored.

The JL4 synchronous servo motors are used for driving machinery, such as conveyors, production machines, and handling machines.

1.1.2 Usage other than agreed upon

The JL4 synchronous servo motor series must not be used in technical systems which to a high degree have to be fail-save, e.g. ropeways and aeroplanes.

If the JL4 synchronous servo motors are to be run under ambient conditions, which differ from the conditions mentioned in chapter 3 "Operating Conditions", page 27, the manufacturer is to be contacted beforehand.

1.1.3 Who is permitted to operate the JL4 servo motor?

Only instructed, trained and authorised persons are permitted to operate the JL4 synchronous servo motor series.

Transport:	Only by personnel with knowledge in handling electrostatically sensitive components.
Installation:	Only by specialists with training in mechanical and/or electrical engineering.
Commissioning:	Only by specialists with extensive knowledge of, and experience with, electrical engineering / drive technology.

1.1.4 Modifications and alterations to the motor

For safety reasons, no modifications and changes to synchronous servo motors of the JL4 series and to their functions are permitted.

Any modifications to the motor not expressly authorised by the manufacturer will result in a loss of any liability claims to Jetter AG.

The original parts are specifically designed for the JL4 synchronous servo motor series. Parts and equipment of other manufacturers are not tested on our part, and are, therefore, not released by us.

The installation of such parts may impair the safety and the proper functioning of the motor.

For any damages resulting from the use of non original parts and equipment, any claims with respect to liability of Jetter AG are excluded.

1.1.5 Repairing and servicing the JL4 servo motor

The synchronous servo motors of the JL4 series must not be repaired by the operator. The synchronous servo motors of the JL4 series do not contain any parts that could be repaired by the operator.

If a JL4 synchronous servo motors needs repairing, please send it to Jetter AG.

The JL4 synchronous servo motors are maintenance-free. Therefore, no inspection or maintenance is required for their operation.

1.1.6 Decommissioning and disposing of the JL4 servo motor

The environmental regulations for the respective country apply to decommissioning and disposing of the JL4 synchronous servo motors on the operating company's premises.

1.2 Ensure your Own Safety



Danger

➤ Disconnect the JL4 synchronous servo motor from the electricity mains to carry out maintenance work. By doing so, you will prevent accidents resulting from electric voltage and moving parts. Please note chapter 1.3 "Residual Dangers", page 13.

➤ Safety and protective devices, e.g. the barrier and cover of the terminal box or the thermal motor circuit-breaker must not in any case be shunted or by-passed.

➤ Dismantled protective equipment, such as the fuses and the thermal protection units of the motor, must be reattached prior to commissioning and checked for proper functioning.



Danger



➤ **Do not wear protective gloves** for fitting protective equipment. If the motor shaft starts turning inadvertently, the protective gloves could get caught in it.

➤ The JL4 synchronous servo motor can become over 130 °C hot during operation without being damaged. For your own protection, do not touch the motor with bare hands (hazard of burning) before measuring the temperature of the motor enclosure. The machine manufacturer must see to an adequate protection against accidental contact being installed.



➤ Before commissioning, the machine manufacturer must carry out a danger analysis of the respective machine and take adequate measures so that inadvertent motions will not lead to personal injury and to material damage.

1.2.1 Malfunctions



➤ **In case of failures or damages, disconnect the motor from the mains immediately.** Please note chapter 1.3 "Residual Dangers", page 13.

-  Malfunctions or other damages are to be reported to an authorised person at once.
-  Secure the JL4 synchronous servo motors against improper or inadvertent use.

1.2.2 Information signs and labels

-  Writings, information signs, and labels always have to be observed and kept readable.
-  Damaged or unreadable information signs and labels are to be exchanged.

1.2.3 Earthing procedure

-  Please mind proper earthing of servo amplifier and servo motor.
-  Please ensure correct, low-resistance grounding of the frame by PE reference potential in the control cabinet, as otherwise safety of persons will not be guaranteed.
-  The frame should have a conductive, low-resistance connection with the machine into which the servo motor has been integrated.

1.2.4 Activating the holding brake without endangering persons

The holding brakes can be controlled by the servo amplifier directly. In this case, though, the safety of persons is not guaranteed, as suppression on the winding of the brake is carried out without an additional external safety circuit.

If the holding brake is not controlled by the servo amplifier directly, an additional circuit, e.g. by means of a varistor, must be provided. An operation of the holding brake that is safe for personnel requires an additional normally open contact in the brake circuit and a suppressor device, e.g. a varistor, for the brake circuit.

1.3 Residual Dangers

1.3.1 Hazards during operation

HAZARD caused by high operating voltage!



Danger

Extremely hazardous voltages of up to DC 900 V may occur!

These voltages lead to muscle cramps, burns, unconsciousness, respiratory standstill, and death.



Danger



Do not touch or undo electrical connections of the synchronous servo motor while it is live.

The power connections may still be live, even though the motor is not rotating. The operating voltage can amount to up to 900 V.

There is a danger of electric arcing which is a danger to persons and to contacts.



Check all live parts for protection by an electrical barrier.



Caution

DANGER of hot surfaces!

The JL4 synchronous servo motor can heat up during operation. The surface temperature of the motor can exceed 130 °C.



Do not touch the JL4 synchronous servo motor during operation or during the cooling-off period following the switching off of the amplifier.



If there are temperatures exceeding 60 °C, please install protection against accidental contact.



Please make sure that no temperature-sensitive parts have been connected or fastened to the motor.



Danger

DANGER in potentially explosive atmosphere!

- **Do not apply the JL4 synchronous servo motor in potentially explosive areas.**



Caution

DANGER of injuries caused by mechanic force!

This servo motor can move mechanic parts or sharp edges. Therefore, failure or malfunctioning of the amplifier or motor can be dangerous for man or damage the manufacturing plant. This should be prevented by adequate safety precautions.

- One safety precaution is to install a second set of limit switches to interrupt the power supply of the motor.
- Another safety precaution would be to install a guard.

- **Make sure that hazards to persons or material damage are precluded even when the drive is rotating unintentionally.**

- **Do not dismount any necessary guards.**

- **Do not wear gloves, lest they should get caught in the rotating drive shaft.**

- **Never touch a rotating drive shaft.**



Danger

DANGER of feather keys coming loose



Caution

Some motor shafts come with a feather key. If such a shaft is not equipped with a drive element (e.g. gearwheel, sprocket, pulley), the feather key can come loose when the shaft is spinning.

- **For this reason, wear goggles when the shaft is spinning.**

1.3.2 Hazards after POWER has been turned OFF

DANGER resulting from electric shock!



Danger

Capacitors of the servo amplifier can store dangerous voltages for at least 7 minutes after the power has been switched off. The control and power connections may still be live, even though the motor is not rotating.

- Do **never** disconnect the motor when it is under voltage.
- Wait **at least 7** minutes after switching off before disconnecting the servo amplifier and the motor from the mains or disassembling the motor.

1.4 Instructions on EMI

The JL4 synchronous servo motor series has been designed for industrial use. It can cause radio interferences in residential areas. It is operated at the operator's own risk.

The noise immunity of a system corresponds to the weakest component of the system. For this reason, correct wiring and shielding of the cables is important.



Important!

Measures to be taken in order to increase immunity to interfering in electric plants:

- Ground the panel and the frame according to chapter 1.2.3 "Earthing procedure", page 12.
- Connect the resolver respectively the HIPERFACE.
- Connect the motor cables; the toroidal cores or the motor choke must be placed near the servo amplifier; connect shields on both ends of the cables.
- Connect holding brake, if available, and connect shields on both sides of the cables.

- If a motor power cable is used which includes cores for brake control, the brake control cores must be shielded separately. Earth the shielding braid at both ends.
- Follow the instructions given in Application Note 016 "EMC-Compatible Installation of the Electric Cabinet" published by Jetter AG.

The following instructions are excerpts from Application Note 016:

- On principle, **physical separation** should be maintained between signal and power lines. We recommend spacings greater than 20 cm. Cables and lines should cross each other at an angle of 90°.
- All cables must be of a sufficient cross-section.
- Shielded cables **must** be used for the following lines:
Analog lines, data lines, motor cables coming from inverter drives (servo output stage, frequency converter), lines between components and interference suppressor filter, if the suppressor filter has not been placed at the component directly .
- Shield **both sides** of the cable.
- Unshielded wire ends of shielded cables should be as short as possible.
- The **entire** shield must be drawn behind the isolation, and then be **extensively** clamped under a flat earthed strain relief.
- The shield (impedance shielding) **must**, in its entire perimeter, be drawn behind the shielding clamp of the metallised connector housing, respectively of the EMC gland bushing, its greatest possible surface area being clamped under a strain relief.

2 Installation of the Servo Motor

2.1 Scope of Delivery

- Synchronous servo motor of the JL4 series
- Installation manual

Mounting Accessories (not included in the scope of delivery)

- Motor power cable, see chapter 7.1.2 "Motor power cable with mating connector", page 37.
- Resolver cable or HIPERFACE cable, see chapter 7.2.1 "Motor power cable with mating connector", page 43, and chapter 7.3.1 "HIPERFACE cable with mating connector", page 46.
- Digital servo amplifier, e.g. JetMove 2xx or JetMove 6xx.



Note!

If you are not sure which accessories you will need:
The sales staff of Jetter AG will gladly assist you in the selection.

2.2 Important Remarks



Important!



Please read this installation manual before installing and commissioning the JL4 servo motor.



Please keep to the terminal conditions (nameplate and installation manual) and to the technical data of the motor, see chapter 6 "Technical Data", page 31.



Please check the assignments of servo amplifier and motor. Compare the continuous rated current and the AC rated voltage of servo amplifier and motor.

Carry out the wiring according to the electric connection diagrams shown in a manual, e.g. in the operator's manual of the applied servo amplifier JetMove 2xx or JetMove 6xx.

2.2.1 Ambient conditions

For the installation site of the JL4 synchronous servo motor, please give heed to the following ambient conditions:

- Ambient conditions: -20 °C .. +40 °C
- Maximum height of installation position: 1,000 m above sea level
- Relative humidity: 15 .. 85 % (non-condensing)



Important!

In case of a deviation from the ambient conditions specified above, derating might be necessary.

The synchronous servo motor of the JL4 series is not apt for positioning in the open air, nor in corrosive or contaminated surroundings. Such ambient conditions will have negative effects on the service life of the motor.

2.2.2 Avoiding damages



Caution



Do **not** run the JL4 synchronous servo motor at the three-phase supply network directly. The motor **must** be connected to a servo amplifier designed for that purpose, e.g. at a JetMove xxx.

Direct connection to the mains will result in destruction of the motor.



Do not apply excess force when mounting the motor.



Do **by all means** refrain from applying hard blows or shocks to the motor flange and shaft.



For fitting backlash-free output shafts with friction locking, please do by all means only use the specifically designed tightening thread in the motor shaft and warm up the power output elements, if possible.

Fitting the power output elements may only be carried out by means of the suitable tools. Please follow the instructions given by the power output element manufacturers.

A special hint: Apply double-conical collets.



Make sure the clutch is aligned correctly. Please follow the instructions given by the manufacturer of the clutch.

An offset will produce intolerable vibrations and will damage ball bearings and clutch.



When using timing belts, by all means observe the permissible radial forces F_R .

Radial loads exceeding the limits will significantly reduce the service life of motors.

If a belt drive is used, the minimum permitted diameter of the pinion, for example, is calculated as follows: $d_{\min} \geq M_0/F_R \times 2$.



If possible, avoid axial load of the motor shaft.

Axial load will significantly shorten the life of the motor.



Please do by all means set the correct number of motor poles and of resolver poles.

Faulty settings can result in overheating and destruction of the motor.

JL4 synchronous servo motor series:

- Number of motor poles: 6
- Number of resolver poles: 2



Please make sure there is sufficient heat removal in the surroundings and at the flange of the motor. Derate the motor output, if necessary.

During operation with rated data, the flange temperature of 65 °C must not be exceeded.

The thermo protection element must be integrated into the monitoring system of the servo amplifiers.



All torque data have been calculated for motors equipped with cooling plates. For calculating the 3.5 mm thick cooling plates, the following formula would be applied:

Length of cooling plate in mm = 2.5 x flange size in mm

Example:

Cooling plate for a JL2-0040-...-motor = 2.5 x 55 mm = 137.5 mm

The following cooling plate will result for JL2 motor types:

137.5 mm x 137.5 mm x 3.5 mm

2.3 Mechanical Installation



Prior to installing the motor, check it for possible damages in transit and/or storage.

Please do notify us without delay of damaged mechanical equipment, as well as of corrosion damages to shaft or flange.

If there is a brake, release it first. Try to turn the rotor by hand; it must react easily. Watch out for unusual scraping noises.



At manufacturing, the rotor of the motor is balanced electronically.

Before fitting the power output elements to the end of the shaft, remove the corrosion protection they might still be covered with.



Do **by all means** refrain from applying hard blows or shocks to the motor flange and shaft.



For fitting clutches, toothed wheels or pulleys, please do by all means only use the specifically designed tightening thread in the motor shaft, see Fig. 1, and warm up the power output elements, if possible.

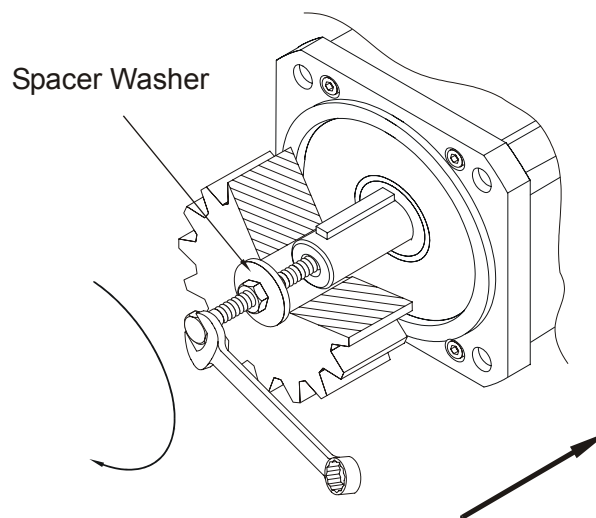

Fig. 1: Example: Fitting a power output element



For fitting power output elements use as far as possible only frictional collets and clutches which are free from backlash.

Please pay attention to the correct alignment of the coupling (as little unbalanced mass as possible).

A balance error produces vibrations and will damage ball bearings and coupling.



Check power output elements (coupling, gearbox, pulley) for tight fit and correct set-up.

- Please give heed to the admissible radial and axial forces. For this, please, do also **by all means** read the chapter 2.2.2 "Avoiding damages", page 19.
- **By all means** avoid a hyperstatic arrangement of the motor shaft bearings by using a rigid clutch and an external additional bearing (e.g. in the gearbox).
- The installation location must be free from conductive and corrosive substances.
For encapsulated installation, please consult our application department.
- Protect the motors against liquids soaking into the bearing in case the shaft end is installed upwards (design V1); refer to Fig. 2.

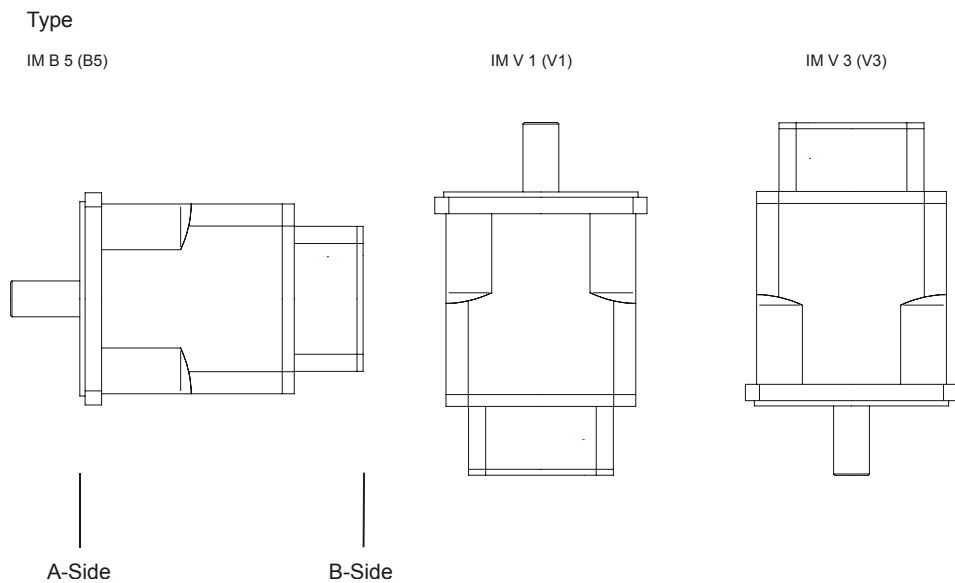

Fig. 2: Mounting Positions of JL4 Motors

- Ensure unobstructed ventilation of the JL4 synchronous servo motor and observe the ambient and flange temperature. The permitted ambient temperature has been specified in chapter 3 "Operating Conditions", page 27. The maximum permitted flange temperature during operation is 65 °C.
- In order to disassemble gears, pulleys etc. please use a pulling device according to Fig. 3.

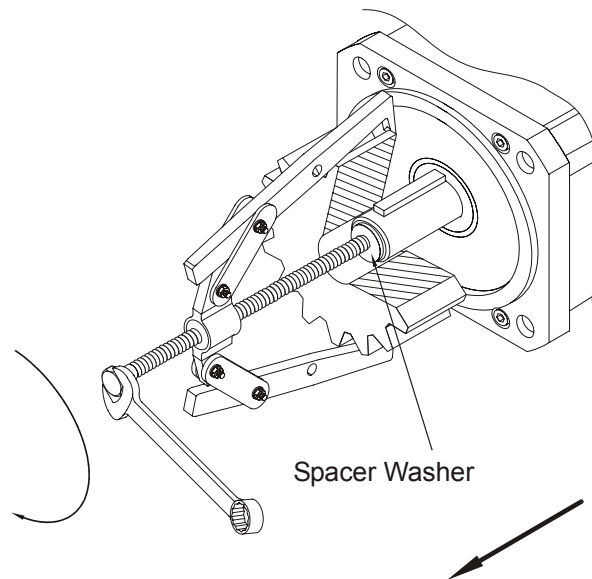

Fig. 3: Disassembling a power output element

2.4 Electrical Installation

- Have installation jobs carried out by qualified personnel only, see chapter 1.1.3 "Who is permitted to operate the JL4 servo motor?", page 10.
- Please check the assignments of servo amplifier and servo motor. Compare the continuous rated current and the AC rated voltage of servo amplifier and motor.
- The cable diameter must be designed according to the continuous rated current of the motor. Please do also observe the ambient conditions, the mode of installation and the local regulations.
- To connect resolver, HIPERFACE or power units, you can use prefabricated cables available from Jetter, or opt for self-made cables. Please refer to chapter 7 "Description of Connections", page 36.
- All cables and pipes have to be run in a way that nobody gets entangled in them. When laying lines, the bending radiuses must be observed.
- Carry out the wiring according to the electric connection diagrams shown in a manual, e.g. in the operator's manual of the applied servo amplifier JetMove xxx.
- Check whether all ground cables are connected, see chapter 1.2.3 "Earthing procedure", page 12.



- For installation according to EMC, the chapter 1.4 "Instructions on EMI", page 15 must be read and observed.
- In addition, the explanations given in the operating manual of the respective servo amplifier, e. g. JetMove xxx, are to be observed. In particular, connect the shields according to the connection diagrams given in the operating manuals of the servo amplifiers.

2.5 Checking the Installation

- Check servo motor and servo amplifier wiring and connections by means of the connection diagrams used.
- A possibly existing holding brake must be checked for proper functioning (attach DC 24 V, the brake must be released then).
- Check to see whether the rotor of the motor can be turned easily (a possibly existing brake must be released beforehand). Watch out for possible unusual scraping noises.
- Check to see whether all necessary protection measures against accidental contact with live or moving parts have been taken.
- Carry out any other checks specific to, or required for, your system.
- Please do by all means set the correct number of motor poles and of resolver poles.
Faulty settings can result in overheating and destruction of the motor.

JL4 synchronous servo motor series:

- Number of motor poles: 6
- Number of resolver poles: 2

Note!

For the digital servo amplifiers JetMove xxx by Jetter AG, the correct motor type must be set. The settings of the motor and resolver pole numbers will then be correct automatically.

- Put the drive into operation according to the operating manual of the servo amplifier.
- When using multi-axis systems, put each drive unit (*servo amplifier / motor*) into operation separately.

2.6 Notes on Safety as regards the Installation



Danger

HAZARD caused by high operating voltage and electric shock!

Extremely hazardous voltages of up to DC 900 V may occur!

Please observe the following precautions in order to avoid muscle cramps, burns, unconsciousness, respiratory standstill, etc., and death:

- Have installation and maintenance jobs carried out by qualified personnel only, see chapter 1.1.3 "Who is permitted to operate the JL4 servo motor?", page 10.
- Switch off the operating voltage.
- Consider the warnings of residual dangers in chapter 1.3.2 "Hazards after POWER has been turned OFF", page 15.
- Before carrying out installation and maintenance jobs, separate the synchronous servo motor and all connected devices from the mains (pull out the mains plug).

2.7 Safety Instructions for Commissioning



Danger

HAZARD caused by high operating voltage and electric shock!

Extremely hazardous voltages of up to DC 900 V may occur!

Please observe the following precautions in order to avoid muscle cramps, burns, unconsciousness, respiratory standstill, etc., and death:

- Have commissioning jobs carried out by qualified personnel only, see chapter 1.1.3 "Who is permitted to operate the JL4 servo motor?", page 10.

Prior to commissioning, do the following:

- Reattach the dismantled thermostatic circuit-breaker and check it for proper functioning.
- Reattach dismantled protective equipment and check it for proper functioning.
By doing so, you will prevent accidents resulting from moving parts.
- Protect the servo motor against accidental contact with live parts and components.
- Only connect devices or electrical components, e.g. resolver, HIPERFACE or servo motor that have been sufficiently separated from the connected electric circuits to the servo motor .
- Each commissioning, even a short functional test, must always be carried out with a PE bus correctly connected.

3 Operating Conditions

Operating Parameters	
Transport	
Temperature	-20 °C to 70 °C; maximum fluctuation: 20 °C per hour
Air Humidity	Relative humidity up to 90 %, no condensation
Climatic Category	Category 2K4 to DIN EN 60721-2-3
Storage	
StoringTemperature	-20 °C to 70 °C; maximum fluctuation: 20 °C per hour
Air Humidity	Relative humidity up to 90 %, no condensation
Climatic Category	Category 1K4 to DIN EN 60721-3-1
Storage	Only in original packing in a dry, dust-free and non-vibrating room
Storage Period	No Limitation
Operation at Rated Data to chapter 6 "Technical Data", page 31	
Ambient Temperature	5 °C to 40 °C at an altitude of up to 1,000 m above sea level
Air Humidity	Relative humidity 15 to 85 %, no condensation
Climatic Category	Category 3K4 to DIN EN 60721-3-3
Installation	<ul style="list-style-type: none"> • Horizontal position (B5) to Fig. 2 on page 22 • If the module is operated at an altitude higher than 1,000 m above sea level, derating will be required. • A clearance of at least 10 cm above and below the module must be maintained to provide proper air circulation.
Derating (Currents and Torques)	<ul style="list-style-type: none"> • 1 % per °C in the range of 40 °C to 50 °C up to 1,000 m above sea level • At altitudes higher than 1,000 m above sea level and 40 °C: <ul style="list-style-type: none"> 6 % at 2,000 m above sea level; 17 % at 3,000 m above sea level; 30 % at 4,000 m above sea level; 55 % at 5,000 m above sea level; • At altitudes higher than 1,000 m above sea level and a temperature reduction of 10 °C per 1,000 m no derating is required.
Maximum Permissible Flange Temperature	65 °C + 10 %
Protective System	IP 65
Insulation Class	F acc. to VDE 0530
EMC	
Electromagnetic Compatibility	<p>Is ensured if the following requirements as to filtering and shielding are fulfilled: (cf. chapter 1.4 "Instructions on EMI", page 15)</p> <ul style="list-style-type: none"> • Emitted interference to DIN EN 50081-1 and DIN EN 50082-2 • Immunity to DIN EN 50082-2

4 Type Designation

	JL	-	4	-	0750	-	44	-	3	R	V	B	P	M	S	C	F	X
Motor type JL																		
Frame size 4																		
Continuous stall torque in Ncm																		
Voltage constant in V/krpm																		
Thermostatic circuit-breaker 3 = Thermostatic circuit-breaker 145 °C *) 4 = Overtemperature protection PTC 6 = KTY83-110																		
Shaft tolerances R - Concentricity tolerance of the shaft ends to DIN 42955R *)																		
Protective system V - Degree of protection IP65 without shaft seal *) V2 = Degree of protection IP65 with shaft seal																		
B - Brake _ = No Brake *) B = brake DC 24 V																		
P - Shaft _ = Plain Shaft *) P = Feather key DIN 6885																		
M - Winding insulation _ = Winding for U_{DC} = 560 V up to 850 V during braking operation *)																		
S - Electric connection _ = Vertical position of the connector *) S-A = Horizontal position of the connector in the direction of the motor shaft S-B = Horizontal position of the connector against the direction of the motor shaft S-X = Horizontal position of the connector; rotatable																		
C- Connector type _ = Encoder connector series RC and motor connector series SC for JL2 through JL4, JK4 through JK6, motor connector series SM for JL5 through JL8, JK7 *) C1 = Encoder connector of the RC series and motor connector of the SC series (only for JL5)																		
F = Encoder type _ = Resolver 2-pin *) F2 = HIPERFACE (SKS36 for JL2 or SRS50 for JL3 through JL8, respectively JK4 through JK7) F3 = HIPERFACE (SKM36 for JL2 or SRM50 for JL3 through JL8, respectively JK4 through JK7)																		
Additional options X - Other configuration (e. g. specific customer requirements) Has been specified further in the product description																		

*) If in an order no specifications have been made on optimum protection against overtemperature and on extras to be provided, the features marked by bold *) are a standard of the respective motor.

Ordering Instructions

- Mating connectors and feather keys have to be ordered separately.
- The JL4 series also includes motors equipped with HIPERFACE.

Selection Criteria

- Continuous stall torque M_o [Nm]
- Rated speed n_n [rpm]
- Rotor inertia of motor and load J [kgcm²]
- RMS torque (calculated) M_{rms} [Nm]

For calculating the required servo motors and servo amplifiers, both the static **and** the dynamic load have to be considered (acceleration and deceleration).

Word of Advice on Accessories

For the operation of synchronous servo motors a motor cable, a resolver or HIPERFACE cable, a servo amplifier and possibly a speed reducer are required. Jetter AG employees would be glad to assist you in selecting the cables, the servo amplifier and a suitable speed reducer.

Word of Advice on the Holding Brake

As an alternative, there are motors with integrated holding brake available. The permanent magnet brake is controlled by DC 24 V; in no-voltage condition, it will block the rotor.

The holding brakes have been designed as standstill brakes!

They are not approved for permanent slowing down the motor as a part of the operating mode!

5 Physical Dimensions

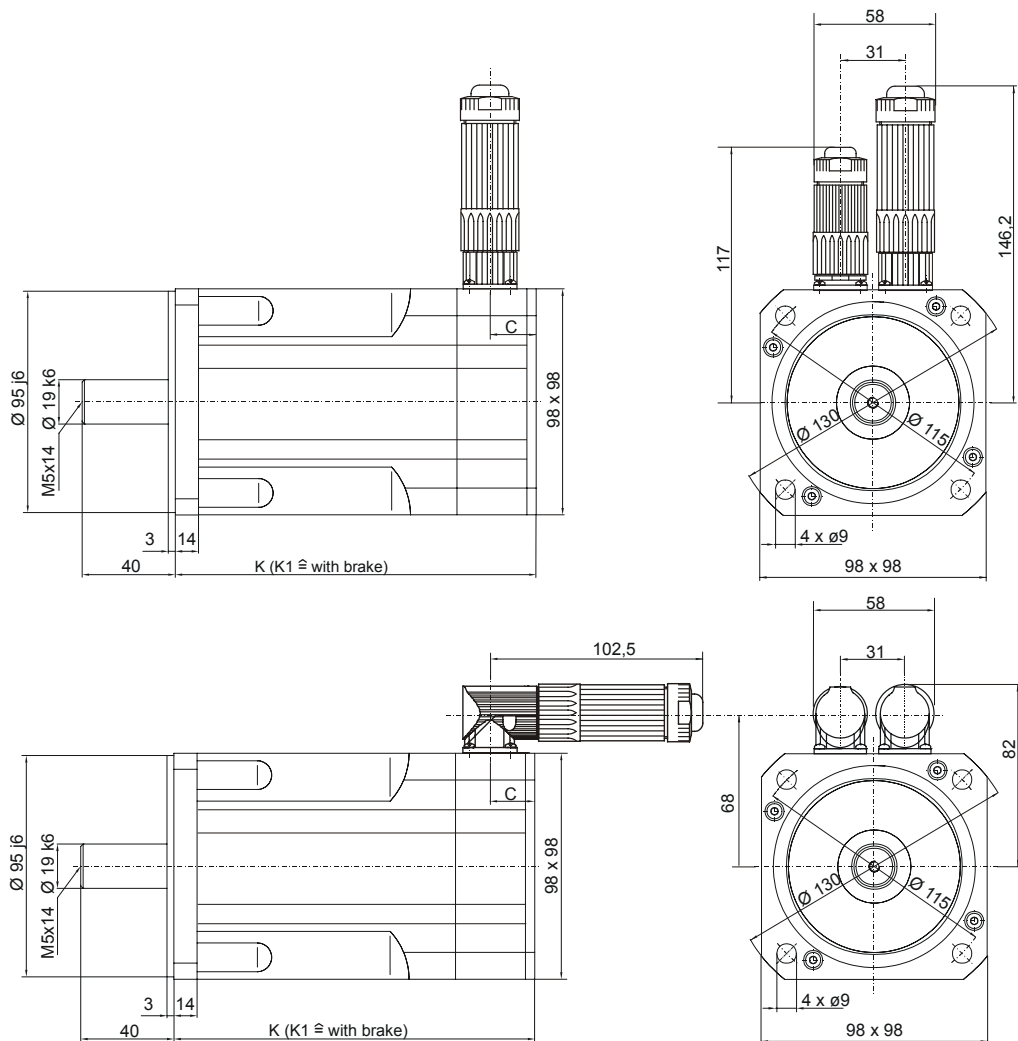

Design with Resolver	K	K1	C
JL4-0530	176	208	19
JL4-0750	221	253	19

Design with HIPERFACE	K	K1	C
JL4-0530	197	229	29,5
JL4-0750	242	274	29,5

All dimensions in mm
 The connectors of the option S-X are positioned 7 mm higher.

Optional motor design with feather key DIN 6885-A 6x6x32

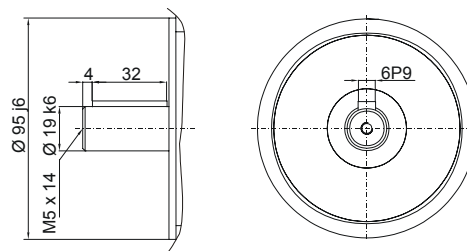

Fig. 4: Mounting dimensions of the JL4 motor series

6 Technical Data

Technical Data - JL4 Synchronous Servo Motor Series, Part 1					
Motor Type			JL4-0530-48	JL4-0530-80	
Motor Data					
Continuous stall torque	M_o	<i>Nm</i>		5.3	5.3
Continuous stall current	I_o	<i>A</i>		6.5	4.11
Voltage constant	K_E	<i>V/krpm</i>		49.5	78
Torque constant	K_T	<i>Nm/A</i>		0.82	1.29
Winding resistance phase to phase	R_{Ph}	Ω		1.66	4.2
Winding inductance phase to phase	L_{Ph}	<i>mH</i>		9.8	24
Electrical time constant	T_{el}	<i>ms</i>		5.90	5.71
Mechanical time constant	T_{mech}	<i>ms</i>		1.14	1.16
Thermal time constant	T_{ther}	<i>min</i>		64	64
Number of motor poles	p_{mot}	-		6	6
Number of resolver poles	p_{res}	-		2	2
Rated Data					
Rated torque	M_n	<i>Nm</i>		4.6	4.6
Rated speed	n_n	<i>rpm</i>		3,000	3,000
Continuous rated current	I_n	<i>A</i>		5.91	3.75
Peak Values					
Peak torque	M_{max}	<i>Nm</i>		21.2	21.2
Peak current	I_{max}	<i>A</i>		38.8	25.1
Peak speed	n_{max}	<i>rpm</i>		12,000	12,000
Mechanical Parameters					
Rotor inertia	J	<i>kg*cm²</i>		2.65	2.65
Weight without brake	m	<i>kg</i>		5.6	5.6
Weight with brake	m_{Br}	<i>kg</i>		6.42	6.42
Axial load *)	F_A	<i>N</i>		128	128
Radial load *)	F_R	<i>N</i>		676	676

Technical Data - JL4 Synchronous Servo Motor Series, Part 1			
Holding Brake for DC 24 V (optional)			
Holding torque	M_{BR}	<i>Nm</i>	9
Supply voltage	U_{BR}	V	DC 24 V (-10 % - +6 %)
Rated output	P_{BR}	<i>W</i>	18
Rotor inertia	J_{Br}	<i>kg*cm²</i>	0.54
Other Technical Data			
Painting	Dull black, colour RAL 9005 (no stability to solvents, such as Trilene, thinners, etc.)		
Ball bearing service life	≥ 20,000 operating hours		
Thermal motor protection	Thermo switch 145 °C, optional PTC resistor, respectively NTC resistor		
Brake trip point	24 V - 5 %, and 24 V + 10 %		

All specified current and voltage values are RMS values.

*) Maximum permitted radial respectively axial force at 3,000 rpm. **The axial force F_A must not become greater than a third of the radial force F_R .**

Technical Data - JL4 Synchronous Servo Motor Series, Part 2					
Motor Type			JL4-0750-44	JL4-0750-53	JL4-0750-96
Motor Data					
Continuous stall torque	M_o	<i>Nm</i>	7.5	7.5	7.5
Continuous stall current	I_o	<i>A</i>	10.5	9.1	4.82
Voltage constant	K_E	<i>V/krpm</i>	43	50	94
Torque constant	K_T	<i>Nm/A</i>	0.71	0.83	1.55
Winding resistance phase to phase	R_{Ph}	<i>Ω</i>	0.64	0.87	3.0
Winding inductance phase to phase	L_{Ph}	<i>mH</i>	4.1	5.6	19.2
Electrical time constant	T_{el}	<i>ms</i>	6.41	6.44	6.40
Mechanical time constant	T_{mech}	<i>ms</i>	0.91	0.91	0.89
Thermal time constant	T_{ther}	<i>min</i>	66	66	66
Number of motor poles	p_{mot}	-	6	6	6
Number of resolver poles	p_{res}	-	2	2	2
Rated Data					
Rated torque	M_n	<i>Nm</i>	6.4	6.4	6.4
Rated speed	n_n	<i>rpm</i>	3,000	3,000	3,000
Continuous rated current	I_n	<i>A</i>	9.43	8.11	4.35
Peak Values					
Peak torque	M_{max}	<i>Nm</i>	30.0	30.0	30.0
Peak current	I_{max}	<i>A</i>	63.3	54.4	29.4
Peak speed	n_{max}	<i>rpm</i>	12,000	12,000	12,000
Mechanical Parameters					
Rotor inertia	J	<i>kg*cm²</i>	4.15	4.15	4.15
Weight without brake	m	<i>kg</i>	7.7	7.7	7.7
Weight with brake	m_{Br}	<i>kg</i>	8.52	8.52	8.52
Axial load *)	F_A	<i>N</i>	135	135	135
Radial load *)	F_R	<i>N</i>	711	711	711

Technical Data - JL4 Synchronous Servo Motor Series, Part 2			
Holding Brake for DC 24 V (optional)			
Holding torque	M_{BR}	Nm	9
Supply voltage	U_{BR}	V	DC 24 V (-10 % - +6 %)
Rated output	P_{BR}	W	18
Rotor inertia	J_{Br}	$kg \cdot cm^2$	0.54
Other Technical Data			
Painting	Dull black, colour RAL 9005 (no stability to solvents, such as Trilene, thinners, etc.)		
Ball bearing service life	$\geq 20,000$ operating hours		
Thermal motor protection	Thermo switch 145 °C, optional PTC resistor, respectively NTC resistor		
Brake trip point	24 V - 5 %, and 24 V + 10 %		

All specified current and voltage values are RMS values.

*) Maximum permitted radial respectively axial force at 3,000 rpm. **The axial force F_A must not become greater than a third of the radial force F_R .**

Corner points

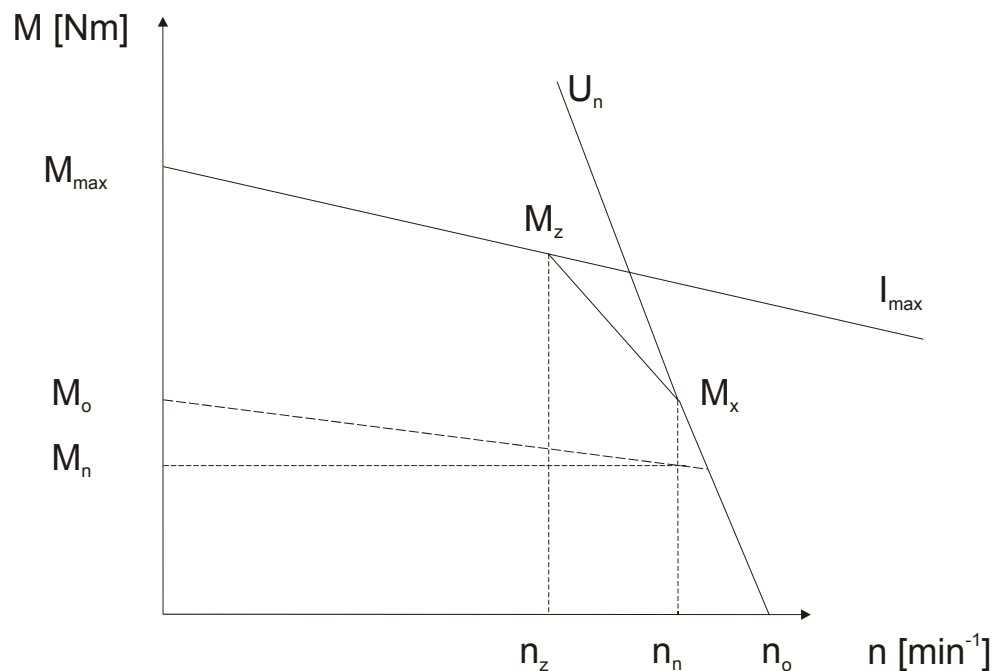

Fig. 5: Characteristic curve according to the JL4 synchronous servo motor series

Corner Points: Characteristic Curves for JL4 Servo Motors, Part 1				
Motor Type			JL4-0530-48	JL4-0530-80
AC rated voltage U_n	V		170	310
Rated torque M_n	Nm		4.6	4.6
Rated speed n_n	rpm		3,000	3,000
Continuous stall torque M_o	Nm		5.3	5.3
Peak torque M_{max}	Nm		21.2	21.2
Peak torque M_x at n_n	Nm		8.66	10.2
Idling speed n_o	rpm		4,040	4,230
Limit speed n_z at $I_{max} + M_z$	rpm		1,220	1,270
Limit torque M_z at $I_{max} + n_z$	Nm		21.02	21.0

Corner Points: Characteristic Curves for JL4 Servo Motors, Part 2				
Motor Type		JL4-0750-44	JL4-0750-53	JL4-0750-96
AC rated voltage U_n	V	170	170	310
Rated torque M_n	Nm	6.4	6.4	6.4
Rated speed n_n	rpm	3,000	3,000	3,000
Continuous stall torque M_o	Nm	7.5	7.5	7.5
Peak torque M_{max}	Nm	30.0	30.0	30.0
Peak torque M_x at n_n	Nm	18.97	14.61	10.1
Idling speed n_o	rpm	4,640	4,000	3,510
Limit speed n_z at $I_{max} + M_z$	rpm	1,870	1,550	1,320
Limit torque M_z at $I_{max} + n_z$	Nm	29.74	29.75	29.6

7 Description of Connections

7.1 Motor Connection by means of the Motor Connector Series SC

7.1.1 General remarks



Important!

Alternative measures to avoid malfunctions of the control system and the motor:



Operate the brake via a separately shielded brake line. The distance between brake line and motor power cable should be greater than 20 cm. This is the preferred solution.



Always connect brake lines to a separate power supply unit DC 24 V if brake and motor lines are run together in one bunch of cables, and are not separately shielded.



Important!

Measures to avoid oscillation and blocking of the motor:



Avoid mixing-up of phase conductors, resp. be sure to connect them according to pin assignment.

7.1.2 Motor power cable with mating connector



Note!

The suitable mating connector (female connector) of the synchronous servo motor series JL4 can be ordered from Jetter AG by supplying the following particulars:

- Article # 15100070 Motor connector JL2-JL4/JK4-JK6 without brake
- Article # 15100105 Motor connector JL2-JL4/JK4-JK6 with brake



Note!

The Jetter Motor power cable of the synchronous servomotor series JL4 is supplied by Jetter AG. It is confectioned with the matching motor connector and can be ordered by the following cable confection numbers:

Without Brake:

- Cable confection # 26.1 For JetMove 203 and JetMove 206
- Cable confection # 26.1 For JetMove 606 through 620

With Brake:

- Cable confection # 24.1 For JetMove 203 and JetMove 206
- Cable confection # 24.1 For JetMove 606 through 620

View on the mating connector of the motor (solder side)

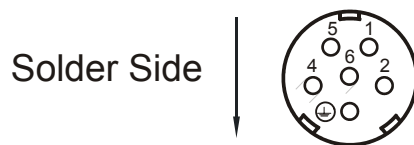

Fig. 6: View on the SC series mating connector of the motor (internal thread M23)

7.1.3 Motor power cable for JetMove 2xx



Motor Power Cable of Cable Confection # 26.1			
Connecting terminals of JetMove 2xx	Shield		Mating connector of the motor (female, solder side)
<p>4 x 1.5 mm² The wires have been equipped with wire end ferrules.</p>	<p>Shielded, highly flexible 4-wire cable with PE.</p>		
		<p>Connect both sides of the shield with the greatest possible surface area! Use metallized housing only!</p>	
Pin	Wire Number	Signal	Pin
X62.U2	1	Phase 1	1
X62.V2	2	Phase 2	5
X62.W2	3	Phase 3	2
X62.PE	Yellow-green	Protective earth	

Dimensions of the motor mating connector are specified in millimeters.

Motor Power Cable of Cable Confection # 24.1			
Connecting terminals of JetMove 2xx	Shield		Mating connector of the motor (female, solder side)
<p>7 x 1.5 mm² The wires have been equipped with wire end ferrules.</p>	<p>Shielded, highly flexible 6-wire cable with PE.</p>		
	<p>Connect both sides of the shield with the greatest possible surface area! Use metallized housing only!</p>		
Pin	Wire Number	Signal	Pin
X62.U2	1	Phase 1	1
X62.V2	2	Phase 2	5
X62.W2	3	Phase 3	2
X62.PE	Yellow-green	Protective earth	
X10.BRAKE2	5	Brake +	6
X10.GND	4	Brake -	4

Dimensions of the motor mating connector are specified in millimeters.

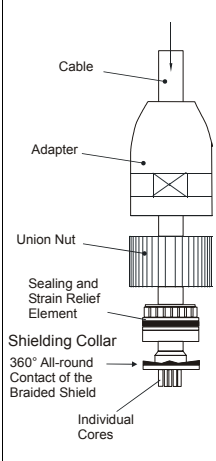
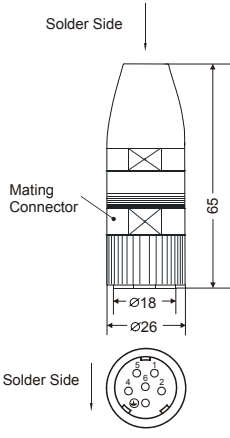
7.1.4 Motor power cable for JetMove 6xx

Motor Power Cable of Cable Confection # 26.1			
Connecting Terminals of JetMove 606 through JetMove 620	Shield		Mating connector of the motor (female, solder side)
<p>4 x 1.5 mm²</p> <p>The wires have been equipped with wire end ferrules.</p>	<p>Shielded, highly flexible 4-wire cable with PE.</p> <p>The shield is not attached to the servo amplifier side.</p> <p>The shield is connected with the servo amplifier via PE.</p>		
	<p>Connect the shield with the greatest possible surface area! Use a metallized housing only!</p>		
Pin	Wire Number	Signal	Pin
X9.U2	1	Phase 1	1
X9.V2	2	Phase 2	5
X9.W2	3	Phase 3	2
X9.PE	Yellow-green	Protective earth	

Dimensions of the motor mating connector are specified in millimeters.

Motor Power Cable of Cable Confection # 24.1			
Connecting Terminals of JetMove 606 through JetMove 620	Shield		Mating connector of the motor (female, solder side)
<p>7 x 1.5 mm²</p> <p>The wires have been equipped with wire end ferrules.</p>	<p>Shielded, highly flexible 6-wire cable with PE.</p> <p>The shield is not attached to the servo amplifier side.</p> <p>The shield has been connected with the servo amplifier via PE.</p>		
	<p>Connect the shield with the greatest possible surface area! Use a metallized housing only!</p>		
Pin	Wire Number	Signal	Pin
X9.U2	1	Phase 1	1
X9.V2	2	Phase 2	5
X9.W2	3	Phase 3	2
X9.PE	Yellow-green	Protective earth	
X9.Brake+	5	Brake +	6
X9.Brake-	4	Brake -	4

Dimensions of the motor mating connector are specified in millimeters.

7.1.5 Connection assignment of terminal box

Connection Assignment of Terminal Box ^{*)}		
Connection Terminals of the Amplifier	Connection Assignment of Motor Terminal Box	
U2	Pin 1	Phase 1
V2	Pin 2	Phase 2
W2	Pin 3	Phase 3
PE	Pin 4	 Protective earth
	Pin 7	Brake +
	Pin 8	Brake -

^{*)} alternatively to motor connectors

7.2 Connection of the Resolver

7.2.1 Motor power cable with mating connector



Note!

The resolver respectively HIPERFACE mating connector of the synchronous servo motor series JL4 can be ordered from Jetter AG by supplying the following particulars:

Article # 15100069 Resolver / HIPERFACE

The complete resolver cable connecting the servo amplifier series JetMove 2xx, respectively JetMove 6xx and the synchronous servo motor series JL4 can be ordered from Jetter AG.

It can be ordered by supplying the following cable confection number:

Cable confection # 23 For the servo amplifier series JetMove 2xx

Cable confection # 423 For the servo amplifier series JetMove 6xx

In case you prefer to fabricate the cables yourself, the following minimum requirements must be met, also considering EMC:

- Max. cable length: 50 m
- Cable size: $3 \times 2 \times 0.14 \text{ mm}^2 + 2 \times 0.5 \text{ mm}^2$;
2 x 0.5 mm² must be used for the thermal sensor
- Twisted-pair cables shielded with the all-over shield must be used
- The shield must be connected to the connector housings on both ends of the cable with the greatest possible surface area.

Mating connector of the resolver (solder side)

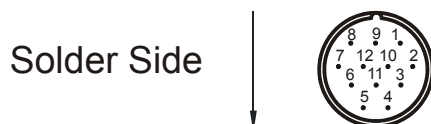
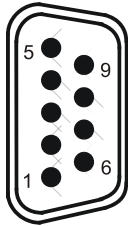
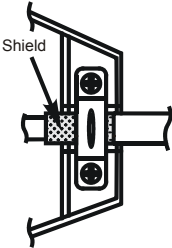
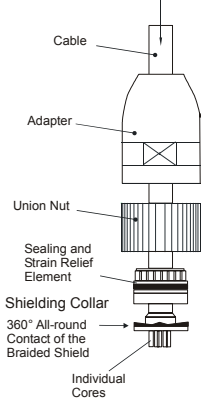
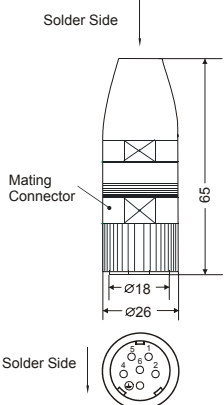

Fig. 7: RC series mating connector of the resolver (internal thread M23)

7.2.2 Resolver cable for JetMove 2xx

Resolver Cable of Cable Confection # 23			
JetMove 2xx (SUB-D connector X61)	Shield		Motor (Resolver) (female, solder side)
 <p>Attaching screws must have a metric thread!</p>			
	<p>Connect the shield with the greatest possible surface area! Use a metallized housing only!</p>		
Pin	Signal	Core Colour	Pin
8	S1 (cosine +)	red	1
3	S3 (cosine -)	blue	2
2	S4 (sine -)	yellow	3
7	S2 (sine +)	green	4
1	R1R (exciter winding +)	pink	5
6	R2L (exciter winding -)	gray	6
9	Th1 (thermal sensor)	white	7
4	Th2 (thermal sensor)	brown	8
-	unused	-	9 - 12

Dimensions of the motor mating connector are specified in millimeters.

7.2.3 Resolver cable for JetMove 6xx

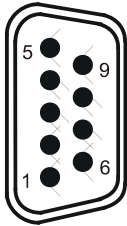
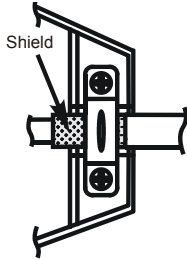
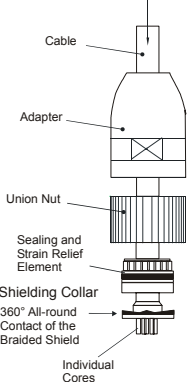
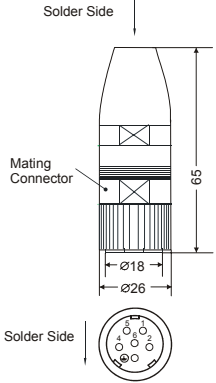
Resolver Cable of Cable Confection # 423			
JetMove 6xx (SUB-D connector X2)	Shield		Motor (Resolver) (female, solder side)
 <p>Attaching screws must have an inch thread!</p>			
Pin	Signal	Core Colour	Pin
4	S1 (cosine -)	red	1
8	S3 (cosine +)	blue	2
7	S4 (sine -)	yellow	3
3	S2 (sine +)	green	4
5	R1R (R +)	pink	5
9	R2L (R -)	gray	6
2	Th1 (thermal sensor)	white	7
6	Th2 (thermal sensor)	brown	8
-	unused	-	9 - 12

Dimensions of the motor mating connector are specified in millimeters.

7.3 HIPERFACE Connection

7.3.1 HIPERFACE cable with mating connector



Note!

The resolver respectively HIPERFACE mating connector of the synchronous servo motor series JL4 can be ordered from Jetter AG by supplying the following particulars:

Article # 15100069 Resolver / HIPERFACE

The complete HIPERFACE cable connecting the servo amplifier series JetMove 2xx, respectively JetMove 6xx and the synchronous servo motor series JL4 can be ordered from Jetter AG.

It can be ordered by supplying the following cable confection number:

Cable confection # 723 For the servo amplifier series JetMove 2xx

Cable confection # 523 For the servo amplifier series JetMove 6xx

In case you prefer to fabricate the cables yourself, the following minimum requirements must be met, also considering EMC:

- Max. cable length: 50 m
- Cable size: 5 x 2 x 0.25 mm²
- Twisted-pair cables shielded with the all-over shield must be used; the signal lines must also be twisted in pairs:
 - Sine + and reference sine
 - Cosine + and reference cosine
 - DATA - and DATA +
 - 0 V and voltage supply
 - thermal sensor
- The shield must be connected to the connector housings on both ends of the cable with the greatest possible surface area.

HIPERFACE mating connector (solder side)

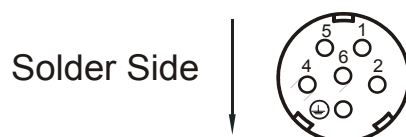
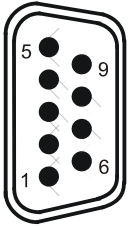
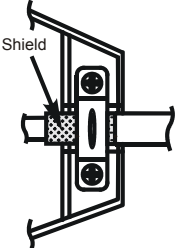
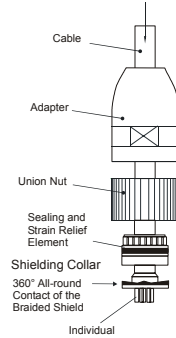
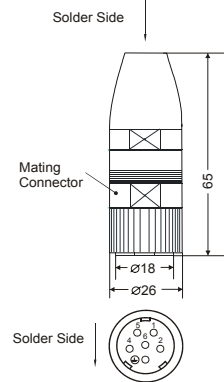

Fig. 8: RC series HIPERFACE mating connector (internal thread M23)

7.3.2 HIPERFACE cable for JetMove 2xx

HIPERFACE Cable of Cable Confection # 723			
JetMove 2xx (SUB-D connector X61)	Shield		Motor (HIPERFACE) (fem., solder side)
 <p>Attaching screws must have a metric thread!</p>			
		<p>Connect shield by greatest possible surface area! Use a metallized housing only!</p>	
Pin	Signal	Core Colour	Pin
-	unused	-	1
-	unused	-	2
7	Sine +	white	3
2	Reference sine	brown	4
8	Cosine +	green	5
3	Reference cosine	yellow	6
6	DATA - (RS-485)	gray	7
1	DATA + (RS-485)	pink	8
4	0 V	blue	9 ^{*)}
5	Power supply (7 through 12 volts)	red	10
9	Thermal sensor	black	11
	Thermal sensor	-	12 ^{*)}

^{*)} Pin 9 and pin 12 are short-circuited. Dimensions of the motor mating connector are specified in millimeters.

7.3.3 HIPERFACE cable for JetMove 6xx

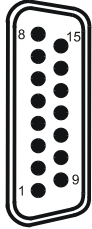
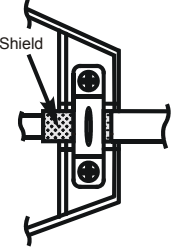
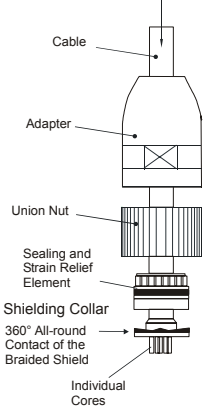
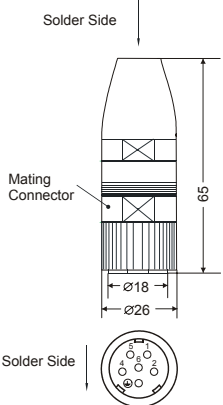
HIPERFACE Cable of Cable Confection # 523			
JetMove 6xx (SUB-D connector X1)	Shield		Motor (HIPERFACE) (female, solder side)
 <p>Attaching screws must have an inch thread!</p>			
	<p>Connect the shield with the greatest possible surface area! Use a metallized housing only!</p>		
Pin	Signal	Core Colour	Pin
-	unused	-	1
-	unused	-	2
1	Sine +	white	3
9	Reference sine	brown	4
3	Cosine +	green	5
11	Reference cosine	yellow	6
13	DATA - (RS-485)	gray	7
5	DATA + (RS-485)	pink	8
2	0 V	blue	9
4	Voltage supply (7 through 12 volts)	red	10
14	Thermal sensor	black	11
7	Thermal sensor	violet	12

Dimensions of the motor mating connector are specified in millimeters.

8 Maintenance of the Motor

Motor maintenance is limited to the following work: Exchanging ball bearings and occasionally cleaning the housing if it is very dirty.



Check the motor every 2,500 operating hours or at least once a year for unusual ball bearing noises.

If there are unusual noises stemming from the ball bearings:



Put the motor out of operation and send it to Jetter AG for being checked.

Do by no means disassemble the motor, as for reassembling, there are specific instructions and settings to be observed.

The ball bearings are equipped with a grease packing adequate for 20,000 service hours under normal operating conditions.



After these 20,000 service hours, the ball bearings must be replaced. For this, please send them to our company.



If there are unusual noises stemming from the motor (not the ball bearings), the motor must be put out of operation and checked.



Use isopropanol or a similar cleaning agent for cleaning the motor frame.

Do not use cleaning agents which contain solvents. On no account immerse the motor in diluent or spray it with diluent.

9 Troubleshooting

Table of Motor Faults		
Type of Error	Error Cause	Troubleshooting
Motor will not start	<ul style="list-style-type: none"> • Servo amplifier not enabled • Setpoint line interrupted • Motor phases mixed up • Brake not released • Drive blocked 	<ul style="list-style-type: none"> • Apply ENABLE signal • Check setpoint line • Connect motor phases correctly • Check brake control • Check drive mechanism
Motor overspeed	<ul style="list-style-type: none"> • Motor phases mixed up 	<ul style="list-style-type: none"> • Connect motor phases correctly
Motor chatters	<ul style="list-style-type: none"> • Resolver line shielding interrupted • Gain factor too high 	<ul style="list-style-type: none"> • Replace resolver line • Use motor default values
Fault message: Brake	<ul style="list-style-type: none"> • Short-circuit in the supply line of the motor holding brake • Motor holding brake defective 	<ul style="list-style-type: none"> • Eliminate short circuit • Replace motor
Fault message: Power stage	<ul style="list-style-type: none"> • Short-circuit or ground fault on motor line • Short-circuit or ground fault in motor 	<ul style="list-style-type: none"> • Replace cable • Replace motor
Fault message: Resolver	<ul style="list-style-type: none"> • Resolver connector has not been plugged on properly • Resolver line interrupted, crushed and the like 	<ul style="list-style-type: none"> • Check plug connection • Check lines
Fault message: Motor Temperature	<ul style="list-style-type: none"> • Motor overtemperature protection tripped • Resolver line loose or interrupted 	<ul style="list-style-type: none"> • Wait until the motor has cooled off. Then, check the cause. • Check connector, possibly replace resolver line
Brake does not grip	<ul style="list-style-type: none"> • Required holding torque is too high • Brake defective • Axial motor shaft overload 	<ul style="list-style-type: none"> • Check dimensioning • Replace motor • Check and reduce axial load. Possibly replace motor if bearings are defective.

Appendices

Appendix A: Recent Revisions

Chapter	Comment	Revised	Added	Deleted
Chapter 5	Physical Dimensions Note: The connectors of the option S-X are positioned 7 mm higher		✓	

Appendix B: Glossary

AC	A lternating C urrent
CE	C ommunautés E uropéennes: European Union
Continuous rated current I_n	At a rated speed n_n and at output of the nominal torque, the motor will collect the continuous rated current. This parameter refers to the sine-effective current value.
Continuous stall current I_o	In order to supply the continuous stall torque during standstill, the motor will consume the continuous stall current. This parameter refers to the sine-effective current value.
Continuous stall torque M_o	Thermal torque limitation which can be output for any length of time at standstill of the motor ($n = 0$ rev/min) and the set ambient conditions.
DC	D irect C urrent
DC link voltage	DC circuit within a servo drive on the basis of which the motor currents are made up, also known as DC bus.
DIN	D eutsches I nstitut für N ormung e.V. [= German Institute for Standardizing]
EC Low Voltage Directive	To be considered when using electric devices of a rated voltage between 50 and 1,000 V AC and between 75 and 1,500 V DC.
Electro-Magnetic Compatibility (EMC)	Definition according to the EMC regulations: "EMC is the ability of a device to function in a satisfactory way in electro-magnetic surroundings without causing electromagnetic disturbances itself, which would be unbearable for other devices in these surroundings."
EN	E uropäische N orm [=European Standard]
EU	E uropean U nion
Hazard analysis	Extract from the 98/37/EC Machinery Directive: "The manufacturer is under an obligation to assess the hazards in order to identify all of those which apply to his machine; he must then design and construct it taking account of his assessment."
HIPERFACE	H igh P erformance I nterface HIPERFACE designates a sensor-transducer system by Sick / Stegmann. The SinCos motor feedback system with the standardised HIPERFACE interface is often used in digital drive technology. Unlike the resolver, the SinCos motor feedback system with HIPERFACE interface contains electronic components. Over several motor rotations, a HIPERFACE will report the absolute position values; this cannot be performed by a resolver. A HIPERFACE is far more precise than a resolver, but also more expensive.
IP	I nternational P rotection

JetMove	<p>JetMove is the product designation of a digital servo amplifier series produced by Jetter AG, e.g. JetMove 206-230. The extension marks the following features:</p> <ul style="list-style-type: none"> – 206 identifies a rated current of 6 A; – 230 identifies the operating voltage of the rated power supply
JetWeb	<p>Control technology comprising control systems, motion systems, user interfaces, visualization devices, remote I/Os and industrial PCs. Programming by means of multitasking and a modern sequence-oriented language. Communication by means of Ethernet TCP/IP and making use of the Web technologies.</p>
Motor circuit-breaker	<p>A circuit-breaker with monitoring functions as to phases and temperature of a motor.</p>
PE	<p>Protective Earth, respectively "Protective Earth Conductor"</p>
Peak current I_{\max}	<p>Permitted peak current for 5 s max.!</p> <p>The peak current should not exceed 3.5 times the value of the continuous rated current.</p>
Power output element	<p>e.g. clutch, gear drive, pulley</p>
Rated torque M_N	<p>When the motor collects its rated current at a rated speed of n_n, the rated torque can be supplied for an unlimited time.</p>
Resolver	<p>Feedback unit at a servo motor for determining the absolute position within one revolution. Other than a HIPERFACE, the resolver will not provide any information on how many revolutions the motor has performed so far.</p> <p>A resolver could be envisaged as a transformer; the couplings of its secondary windings (sine and cosine) change in relation to the position of the motor shaft. Basically, a resolver consists of a rotor with one coil and a stator with two coils. The stator windings are displaced by 90° (sine and cosine). The resolver itself does not contain any electronic components.</p> <p>This resolver-converter uses a 12 bit resolution. One revolution of the shaft is regarded as a circle, which is divided into 4.096 increments.</p>
Rotor inertia J	<p>It is also known as mass moment of inertia. The rotor inertia is a mechanical parameter of rotating bodies. The greater the rotor inertia, the greater is the torque needed to accelerate the body up to the desired speed limit. The mass moment inertia of the motor is the sum of the mass moment of inertia of the rotor and the mass moment of inertia of the resolver. Internal or external expansions (holding brake, encoder system, clutch or mechanical load) can make a significant difference in the values specified here. For this reason, this rotor inertia must be considered as a whole for calculating the dynamic motor situation.</p>
Torque constant K_T	<p>This constant specifies the amount of torque [Nm] that is output by the motor at an RMS current of 1 A.</p> $M = I * K_T$

VDE	Verband deutscher Elektrotechniker e.V. = Association of German Electrical Engineers
Voltage constant K_E	This constant specifies the induced electro-magnetic force of the motor related to 1,000 rev/min as an RMS value between two motor phases.

Units:

A	Ampere
cm	Centimeter (1 cm = 10^{-2} m)
cm ²	Square centimeter
H	Henry
kg	Kilogram
m	Meter
mH	Millihenry (1 mH = 10^{-3} H)
min	Minute
N	Newton
Nm	Newtonmeter
rpm	Revolutions per minute
s	Second
V	Volt
W	Watt
Ω	Ohm
°	Degrees (angular dimension)
°C	Degrees centigrade (temperature unit)

Appendix C: Index of Illustrations

Fig. 1:	Example: Fitting a power output element	21
Fig. 2:	Mounting Positions of JL4 Motors	22
Fig. 3:	Disassembling a power output element	23
Fig. 4:	Mounting dimensions of the JL4 motor series	30
Fig. 5:	Characteristic curve according to the JL4 synchronous servo motor series	34
Fig. 6:	View on the SC series mating connector of the motor (internal thread M23)	37
Fig. 7:	RC series mating connector of the resolver (internal thread M23)	43
Fig. 8:	RC series HIPERFACE mating connector (internal thread M23)	46

Appendix D: Index

A		Cable confection # 523	48
AC rated voltage	9		
Active forces		I	
axial	19	Information signs	12
radial	19	Installation location	22
Ambient conditions	18		
B		L	
Ball bearing noises	49	Laying lines	23
Ball bearing service life	32		
Belt drive	19	M	
Blocking	36	Malfunctions	11, 36
		Mechanical installation	21
C		Mode of installation	22
Cable confection #	37, 43, 46	Modifications	10
Checking the installation	24	Motor cable diameter	23
Cleaning	49	Motor power cable	
Clutch	19, 21	JetMove 2xx	
Collets	21	Cable confection # 24.1	39
Corrosion damages	21	Cable confection # 26.1	38
		JetMove 6xx	
		Cable confection # 24.1	41
		Cable confection # 26.1	40
D		Motor shaft	
Damages in transit and storage	21	avoid hard blows	19
Description of symbols	5	storage	22
Disposing	11	Mounting accessories	17
E		N	
Earthing procedure	12	Noise immunity	15
Electrical installation	23		
EMC-compatible installation	16	O	
		Operating parameters	27
F		Ordering instructions	29
Fitting the power output element	19, 21	Oscillation	36
Flange temperature	19		
		P	
H		Pulling device	22
HIPERFACE cable			
JetMove 2xx		Q	
Cable confection # 723	47	Qualified staff	10
JetMove 6xx			



Jetter AG

Gräterstraße 2
D-71642 Ludwigsburg

Germany

Phone: +49 7141 2550-0
Phone -
Sales: +49 7141 2550-433
Fax: +49 7141 2550-425
Fax
Sales: +49 7141 2550-484
Hotline: +49 7141 2550-444
Internet: <http://www.jetter.de>
E-mail: sales@jetter.de

Subsidiaries

Jetter Asia Pte. Ltd.

32 Ang Mo Kio Industrial Park 2
#05-02 Sing Industrial Complex
Singapore 569510

Singapore

Phone: +65 6483 8200
Fax: +65 6483 3881
E-mail: sales@jetter.com.sg
Internet: <http://www.jetter.com.sg>

Jetter (Schweiz) AG

Münchwilerstraße 19
CH-9554 Tägerchen

Switzerland

Phone: +41 719 1879-50
Fax: +41 719 1879-69
E-mail: info@jetterag.ch
Internet: <http://www.jetterag.ch>

Jetter USA Inc.

165 Ken Mar Industrial Parkway
Broadview Heights
OH 44147-2950

U.S.A.

Phone: +1 440 8380860
Fax: +1 440 8380861
E-mail: bschulze@jetterus.com
Internet: <http://www.jetterus.com>