



**isel**® *From Components to Systems*

# EUROSCOOTER II

with **CE-CERTIFICATION**  
and **ROAD APPROVAL**



**Expansion option:**  
new vehicle with all-round light, blue LED spotlights in front and rear with fastening strap and already mounted holder.



- EuroScooter2 with 1000 W wheel hub motor, maximum speed 15 km/h, range approx. 40 km, weight ES 135: 95 kg / ES 175: 130 kg
- solid steel frame with double base plate and anti slip mat for battery pack 48 V / 20 / 30 Ah with motor control system
- shifter for 1 speed forward and 1 reverse gear, LED headlights, LED backlight, key switch and charger
- front wheel Ø16 inch with two hydraulic disc brake as well as an electric brake with energy recovery
- rear wheels Ø10 inch, guard plate with license number; maximum permitted weight 250 kg



hydraulic disc brake with parking brake



detachable LED spotlight with battery operation

Key switch, forward / reverse function key and charging status

*...for best quality and price...*

## ORDER DATA

EuroScooter2, internally usage	dimensions LxWxH [mm]	loading area BxL [mm]	part no.
ES 135	1350 x 780 x 1000	600 x 550	440703
ES 175	1750 x 780 x 1000	600 x 940	440704

EuroScooter2, with MOT approval	dimensions LxWxH [mm]	loading area BxL [mm]	part no.
ES 135	1350 x 780 x 1000	600 x 550	440705
ES 175	1750 x 780 x 1000	600 x 940	440706

## ACCESSORIES

brochure box	dimensions LxWxH [mm]	item no.
DIN lang	110 x 85 x 205	442085 1000
DIN A5	170 x 85 x 205	442087 1000
DIN A4	235 x 98 x 275	442088 1000

euro-containers	dimensions LxWxH [mm]	item no.
EUK 6412	600 x 400 x 120	443111 0003
EUK 8612	800 x 600 x 120	443111 0004
EUK 6423	600 x 400 x 230	443111 0006
EUK 8623	800 x 600 x 230	443111 0007

	dimensions LxWxH [mm]	item no.
Seat with armrests	450 x 480 x 405	440701 0022

## DIMENSIONED DRAWING

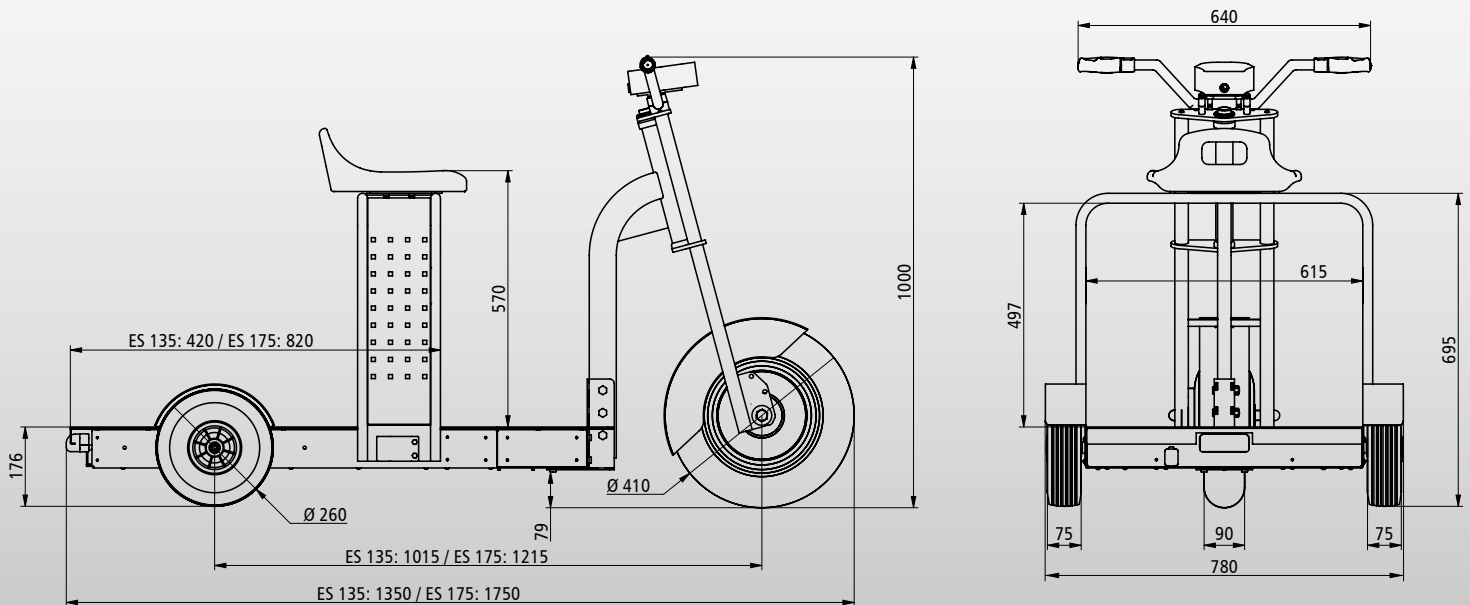

Optional seat with armrests



brochure box  
DIN lang, A4 and A5

euro-containers, available in various sizes

